ADVANTEST
ADVANTEST CORPORATION

R3261/3361 SERIES
SPECTRUM ANALYZER
MAINTENANCE MANUAL

MANUAL NUMBER MEJ00 9407

Before reselling to other corporations
or re-exporting to other countries, you
are required to obtain permission from
both the Japanese Government under its
Export Control Act and the U.S. Govern-
ment under its Export Control Law.



Safety Summary

To ensure thorough understanding of all functions and to ensure efficient use of this instrument, please read the manual carefully before using. Note that Advantest bears absolutely no responsibility for the result of operations caused due to incorrect or inappropriate use of this instrument.

If the equipment is used in a manner not specified by Advantest, the protection provided by the equipment may be impaired.

■ Warning Labels

Warning labels are applied to Advantest products in locations where specific dangers exist. Pay careful attention to these labels during handling. Do not remove or tear these labels. If you have any questions regarding warning labels, please ask your nearest Advantest dealer. Our address and phone number are listed at the end of this manual.

Symbols of those warning labels are shown below together with their meaning.

- DANGER:** Indicates an imminently hazardous situation which will result in death or serious personal injury.
- WARNING:** Indicates a potentially hazardous situation which will result in death or serious personal injury.
- CAUTION:** Indicates a potentially hazardous situation which will result in personal injury or a damage to property including the product.

■ Basic Precautions

Please observe the following precautions to prevent fire, burn, electric shock, and personal injury.

- Use a power cable rated for the voltage in question. Be sure however to use a power cable conforming to safety standards of your nation when using a product overseas. Do not place anything heavy on top of the power cable.
- When inserting the plug into the electrical outlet, first turn the power switch OFF and then insert the plug as far as it will go.

- When removing the plug from the electrical outlet, first turn the power switch OFF and then pull it out by gripping the plug. Do not pull on the power cable itself. Make sure your hands are dry at this time.
- Before turning on the power, be sure to check that the supply voltage matches the voltage requirements of the instrument.
- Be sure to plug the power cable into an electrical outlet which has a safety ground terminal. Grounding will be defeated if you use an extension cord which does not include a safety ground terminal.
- Be sure to use fuses rated for the voltage in question.
- Do not use this instrument with the case open.
- Do not place objects on top of this product. Also, do not place flower pots or other containers containing liquid such as chemicals near this product.
- When the product has ventilation outlets, do not stick or drop metal or easily flammable objects into the ventilation outlets.
- When using the product on a cart, fix it with belts to avoid its drop.
- When connecting the product to peripheral equipment, turn the power off.

■ Caution Symbols Used Within this Manual

Symbols indicating items requiring caution which are used in this manual are shown below together with their meaning.

- DANGER :** Indicates an item where there is a danger of serious personal injury (death or serious injury).
- WARNING :** Indicates an item relating to personal safety or health.
- CAUTION :** Indicates an item relating to possible damage to the product or instrument or relating to a restriction on operation.

■ Safety Marks on the Product

The following safety marks can be found on Advantest products.



: ATTENTION - Refer to manual.



: Protective ground (earth) terminal.



: DANGER - High voltage.



: CAUTION - Risk of electric shock.

■ Precautions when Disposing of this Instrument

When disposing of harmful substances and batteries, be sure dispose of them properly with abiding by the state-provided law.

Harmful substances: (1) PCB (polycarbon biphenyl)
(2) Mercury
(3) Ni-Cd (nickel cadmium)
(4) Other

Items possessing cyan, organic phosphorous and hexadic chromium and items which may leak cadmium or arsenic (excluding lead in solder).

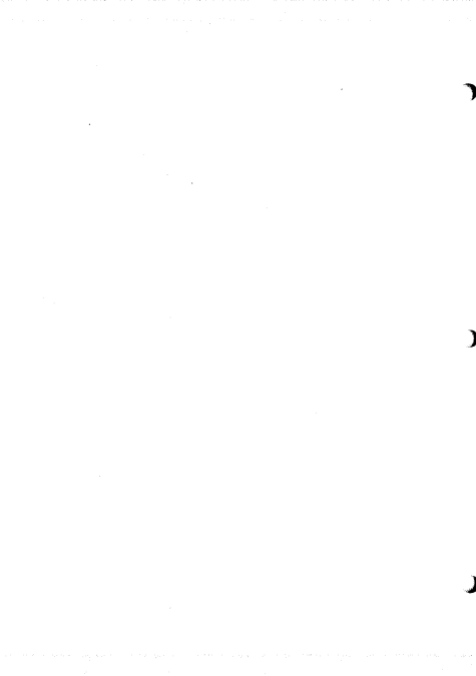







Table of Power Cable options

There are six power cable options (refer to following table).
Order power cable options by Accessory Codes.

	Plug Configuration	Standards	Rating, Color and Length	Accessory Codes (Option Number)
1		JIS: Japan Law on Electrical Appliances	125V at 7A Black 2m (6ft)	Straight: A01402 (Standard) Angled: A01412
2		UL: United States of America CSA: Canada	125V at 7A Black 2m (6ft)	Straight: A01403 (Option 95) Angled: A01413
3		CEE: Europe VDE: Germany OVE: Austria SINCO: Sweden DENKO: Denmark KEMA: Holland FIMKO: Finland NEKO: Norway CEREC: Belgium	250V at 6A Gray 2m (6ft)	Straight: A01404 (Option 96) Angled: A01414
4		SEV: Switzerland	250V at 6A Gray 2m (6ft)	Straight: A01405 (Option 97) Angled: A01415
5		SAA: Australia, New Zealand	250V at 6A Gray 2m (6ft)	Straight: A01406 (Option 98) Angled: —
6		BS: United Kingdom	250V at 6A Black 2m (6ft)	Straight: A01407 (Option 99) Angled: A01417



Safety Summary

The Safety precautions listed below must be followed when operating, servicing, or calibrating this instrument. Failure to follow these precautions or with warnings listed elsewhere in this manual violates safety standards of design, manufacture, and intended use of the instrument. Advantest assumes no liability for the customer's failure to comply with these safety precautions.

GROUND INSTRUMENT

This instrument is equipped with a three-prong ac power cable. It must be plugged into a three-hole grounded outlet or a two-pronged adapter that is firmly grounded to the power outlet.

DO NOT OPERATE IN A WET OR EXPLOSIVE ATMOSPHERE

This instrument is neither waterproof nor explosion proof. Keep the instrument away from water, flammable gases, and explosive fumes.

KEEP AWAY FROM LIVE CIRCUITS

Operating personnel must not remove instrument covers. Only qualified maintenance personnel are allowed to service instrument. Make sure power cable is disconnected before replacing any components. Make sure power cable is disconnected and circuits have been discharged before touching circuits.

DO NOT SERVICE OR ADJUST ALONE

Do not service or adjust this instrument unless another person capable of rendering first aid and resuscitation is present.

DO NOT SUBSTITUTE PARTS OR MODIFY INSTRUMENT

Substitution of parts or modification of this instrument may introduce safety hazards.

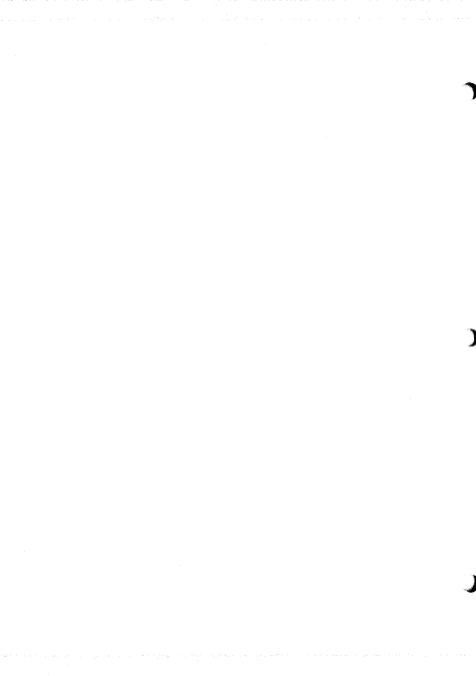

R3261/3361
SPECTRUM ANALYZER
MAINTENANCE MANUAL

Table of Contents

TABLE OF CONTENTS

1. INTRODUCTION	1-1
1.1 How to Use This Manual	1-1
1.2 Over View	1-2
2. SPECIFICATIONS	2-1
2.1 R3261A/C Specifications	2-1
2.2 R3261AN/CN Specifications	2-6
2.3 R3261B/D Specifications	2-11
2.4 R3361A/C Specifications	2-16
2.5 R3361AN/CN Specifications	2-22
2.6 R3361B/D Specifications	2-28
3. THEORY OF OPERATION	3-1
3.1 How a Spectrum Analyzer Works	3-1
3.2 R3261/3361 Configurations	3-2
3.3 How the R3261/3361 Works	3-2
3.3.1 The Input Attenuator	3-4
3.3.2 First Mixer/Coupler	3-5
3.3.3 Second Mixer/Second Local	3-6
3.3.4 Third and Fourth Mixers and Local Oscillators	3-8
3.3.5 IF Step Amplifiers	3-10
3.3.6 LOG/QP	3-13
3.3.7 Analog-to-digital Conversion and Ramp Generator	3-14
3.3.8 First Local Oscillator	3-16
3.3.9 RF Control	3-20
3.3.10 YTO Driver	3-22
3.3.11 CAL Amplifier	3-23
3.3.12 Tracking Generator (R3361A,C/B,D Only)	3-24
3.3.13 Central Processing Unit and Peripherals	3-28
3.3.14 Counter Operation	3-32
3.3.15 Power Source	3-32
3.4 Location	3-33
3.4.1 Block/Board Layout	3-33
3.4.2 RF Block Internal View	3-34
3.4.3 TG Block Internal View	3-35

R3361/3361
SPECTRUM ANALYZER
MAINTENANCE MANUAL

Table of Contents

4. PERFORMANCE TEST	4-1
4.1 General	4-1
4.1.1 Testing Equipment	4-1
4.1.2 Calibration	4-2
4.2 Testing CAL Signals	4-3
4.3 Test Using Internal Signal	4-5
4.3.1 Testing Noise Sideband	4-5
4.3.2 Testing Frequency Drift	4-6
4.3.3 Testing Resolution Bandwidth (3dB bandwidth)	4-7
4.3.4 Testing Selectivity of Resolution Bandwidth	4-9
4.3.5 Testing Stability of QP Bandwidth	4-11
4.3.6 Testing Stability of Marker Indication (In normal mode)	4-13
4.3.7 Testing Stability of Marker Indication (In counter mode)	4-14
4.3.8 Testing Average Noise Level	4-15
4.3.9 Testing Residual Response	4-15
4.3.10 Testing Switchover Stability of Resolution Bandwidth	4-17
4.4 Testing Using Measuring Equipment	4-18
4.4.1 Testing Stability of Reference Oscillator	4-18
4.4.2 Testing Stability of Center Frequency	4-19
4.4.3 Testing Stability of Frequency Span	4-21
4.4.4 Testing LOG Linearity	4-23
4.4.5 Testing LIN Linearity	4-27
4.4.6 Testing Stability of Reference Level	4-28
4.4.7 Testing Stability of Input Attenuator Changeover	4-30
4.4.8 Testing Frequency Response	4-32
4.4.9 Testing Spurious Response	4-34
4.4.10 Testing Stability of Sweep Time	4-36
4.4.11 Testing Stability of TG Output Level (For R3361A,C/B,D only)	4-38
4.4.12 Testing TG Frequency Response (For R3361A,C/B,D only)	4-39
4.4.13 Testing Stability of TG Output Level Changeover (For R3361A,C/B,D only)	4-40
4.4.14 Testing Output Spurious (For R3361A,C/B,D only)	4-41
4.4.15 Testing TG Leak (For R3361A,C/B,D only)	4-42
4.5 Test Report	4-43
5. ADJUSTMENTS	5-1
5.1 Measurement Standards and Support Measuring and Test Equipment Requirements	5-2

R32613861
SPECTRUM ANALYZER
MAINTENANCE MANUAL

Table of Contents

5.2 Preliminary Operations	5-5
5.3 Calibration Process	5-6
5.3.1 Center Frequency Accuracy Adjustment	5-10
(1) 10MHz Frequency Reference Adjustment	5-10
(2) YTO Adjustment	5-11
5.3.2 Frequency Span Adjustment	5-14
(1) Main Span	5-15
(2) 10MHz Span	5-16
(3) 2MHz Span	5-17
(4) LOG Span	5-18
5.3.3 Resolution Band Width Accuracy Adjustment	5-19
5.3.4 Resolution Band Width Switching Between Adjustment	5-28
(1) IF-1	5-29
(2) IF-2	5-32
5.3.5 LOG/LINEAR Amplifier Linearity Adjustment	5-35
LINER MODE	5-36
LOG MODE	5-37
QP MODE ADJ	5-38
IF GAIN ADJ	5-39
5.3.6 Reference Level Adjustment	5-40
(1) Step Amp	5-40
(2) RF Total Gain ADJ	5-43
5.3.7 TG Output Level Accuracy	5-47
6. MAINTENANCE (TROUBLESHOOTING)	6-1
6.1 Level Down	6-1
6.2 Unlock	6-4
6.3 TG Failure	6-8
6.4 Power Supply	6-11
6.5 CRT Unit	6-12

R3261/3361
SPECTRUM ANALYZER
MAINTENANCE MANUAL

Table of Contents

7. REPLACEABLE ELECTRICAL PARTS, CIRCUIT DIAGRAMS AND LOCATION 7-1

	BOARD NAME	PCB ASSEMBLY	PARTS LIST	CIRCUIT LAYOUT	PARTS LOCATION	CIRCUIT DIAGRAM
	IC CARD	BGC-015745	7-2	-	7-3	7-4 to 7-5
	CONTROL	BLQ-015670	7-7 to 7-8	-	7-9	7-10 to 7-26
	RF CONTROL	BLL-015672	7-27 to 7-30	7-31	7-32	7-33 to 7-34
	IF SECTION	BLQ-015668	7-35 to 7-54	7-55	7-56	7-57 to 7-94
	CPU	BLQ-015669	7-95 to 7-96	-	7-99	7-100 to 7-132
	TG KEY	BLB-015775	7-133	-	-	7-135
	KEY	BLG-015673	7-137	-	7-139	7-140 to 7-141
R F	RF BLOCK	WBL-3261RF	7-143	7-145	7-146	7-149
		WBL-3361RF	7-144	7-147	7-148	
	CAL AMP	BLB-015646	7-151	7-145	7-146	7-153
	YTO DRIVER	BLB-015647	7-155 to 7-156	7-157	7-158	7-159 to 7-160
	10MHz REF.	BLB-015727	7-161	7-147	7-148	7-163
	SAMPLER	BTB-016118	7-165	7-145	7-146	7-167 to 7-168
	VCO CONT	BLC-015650	7-169 to 7-170	7-145	7-146	7-171
	3RD CONV	BLG-015645	7-173 to 7-180	7-145	7-146	7-181 to 7-183
	YTO SYNTH	BLK-015649	7-185 to 7-192	7-145	7-146	7-193 to 7-196
	INPUT ATT	BTB-015641	7-197	7-145	7-146	7-199
	1ST MIXER	BTB-015642	7-201	7-145	7-146	7-203
	2ND CONV	STD-015644	7-205 to 7-207	7-145	7-146	7-209 to 7-210
	TG BLOCK	WBL-3361TG	7-211	7-213 7-215	7-214 7-216	7-217
	OUTPUT AMP	BED-015986	7-219 to 7-221	7-215	7-216	7-223
TG SAMPLER	BLB-015987	7-225	7-213	7-214	7-227	
T G	ALC CONT.	BLC-015680	7-229 to 7-230	7-215	7-216	7-231
	T.G CONT.	BLC-015681	7-233	7-235	-	7-236
	TG PLL	BLD-015988	7-237 to 7-238	7-213	7-214	7-239
	4GHz OSC	BTB-015676	7-241	7-215	7-216	7-243
	TG MIX-1	BTB-015722	7-245	7-213	7-214	7-247
	TG MIX-2	BTB-015723	7-249	7-213	7-214	7-251
	MOTHER	BLH-015674	7-253	-	-	7-255 to 7-256
	BATT. HOLDER	BLB-016053	7-257	-	-	7-259

R32610361
SPECTRUM ANALYZER
MAINTENANCE MANUAL

Table of Contents

8. REPLACEABLE MECHANICAL PARTS	8-1
---------------------------------------	-----

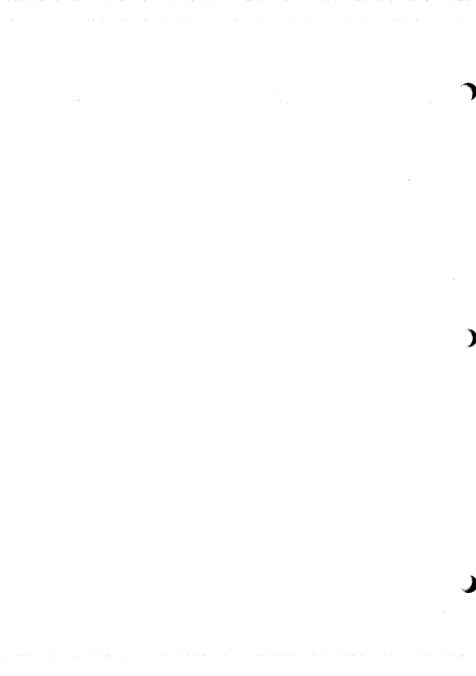

R3261/3361
SPECTRUM ANALYZER
MAINTENANCE MANUAL

List of Illustrations

LIST OF ILLUSTRATIONS

No.	Title	Page
3-1	Typical Spectrum Analyzer Display	3-1
3-2	R3261/3361 Block Diagram	3-3
3-3	Input Attenuator	3-4
3-4	First Mixer/Coupler	3-5
3-5	Second Mixer/Second Local Oscillator	3-6
3-6	Spectrum Distribution at the MON OUT Terminal	3-7
3-7	Third and Fourth Mixers and Local Oscillators	3-8
3-8	IF1 and IF2 Step Amplifiers	3-10
3-9	LOG/QP	3-13
3-10	A/D Conversion and Ramp Generator	3-15
3-11	First Local Oscillator	3-16
3-12	400MHz P.L.L.	3-18
3-13	YTO P.L.L.	3-19
3-14	RF Control	3-21
3-15	YTO Driver	3-22
3-16	CAL Amplifier	3-23
3-17	Tracking Generator Block Diagram	3-24
3-18	Output Amplifier	3-25
3-19	TG Mixer	3-26
3-20	4GHz Oscillator	3-27
3-21	R3261/3361 Mother Board	3-28
3-22	Debug Mode Display	3-31
3-23	Power Source	3-32
3-24	Block/Board Layout	3-33
3-25	RF Block Internal View	3-34
3-26	TG Block Internal View	3-35
6-1	Voltage Check Points	6-11
6-2	Fine Adjustment of The CRT Unit	6-12
6-3	CRT and Power Supply Assembly	6-13

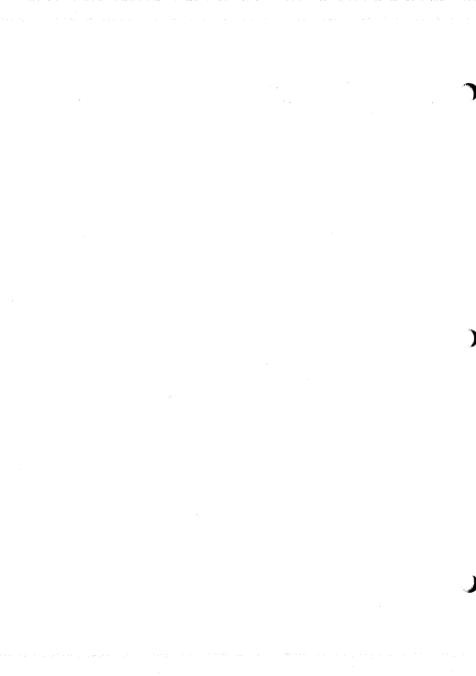

R3261/3361
SPECTRUM ANALYZER
MAINTENANCE MANUAL

List of Tables

LIST OF TABLES

No.	Title	Page
3-1	R3261/3361 Configurations	3-2
3-2	Attenuator Switch Settings	3-4
3-3	RBW Setup	3-11
3-4	REF LEVELS and Step Amplifier Settings	3-12
3-5	SPAN Setting and P.LL Functions	3-16
3-6	400MHz VCO Loop Filter Settings	3-17
3-7	YTO P.LL. Loop Filter Settings	3-20
3-8	CAL LEVELS and CAL SIGNALS	3-23
3-9	Switch Settings for TG Output Levels	3-25
3-10	Memory Map	3-29
3-11	Hexadecimal Values of R3261/3361 Keys	3-31
4-1	Testing Equipment	4-1
4-2	Cable and Adapters Required	4-2
4-3	Relationship Between Resolution Bandwidth and Span	4-8
4-4	Settings for Resolution Bandwidth Selectivity Test	4-10
4-5	CISPR Standards for QP Value Measurement Basic Characteristic	4-11
4-6	Setting in The QP Bandwidth Stability Test	4-12
4-7	Relationship Between Resolution Bandwidth and FREQ SPAN	4-17
4-8	FREQ SPAN and Center Frequency Stability	4-19
4-9	REF LEVEL and External Attenuator Settings	4-29
4-10	Testing Stability of Input Attenuator Changeover	4-31
4-11	CENTER FREQ and SPAN for Dynamic Range Test	4-35
4-12	Stability of TG Output Level Changeover	4-40
5-1	Measurement Standards (MS) Performance Requirements	5-3
5-2	Support Measuring and Test Equipment (S-M&TE) Performance Requirements ...	5-4
7-1	Contents for Chapter 7	7-1



1. INTRODUCTION

This chapter explains how to use this manual, and features of this spectrum analyzer.

1.1 How to Use This Manual

1. INTRODUCTION	This chapter explains how to use this manual, and features of this spectrum analyzer.
2. SPECIFICATION	This chapter lists the R3261/3361 series specifications and accessories.
3. THEORY OF OPERATION	This chapter describes the operation of spectrum analyzer.
4. PERFORMANCE TESTS	This chapter describes functions and cables necessary to the performance test for spectrum analyzer, and the method of performance test.
5. CALIBRATION (REFER TO NCSL)	This chapter describes the method of calibrating the spectrum analyzer.
6. MAINTENANCE (TROUBLESHOOTING)	This chapter describes the method of troubleshooting the spectrum analyzer.
7. REPLACEABLE ELECTRICAL PARTS, CIRCUIT DIAGRAMS AND LOCATIONS	This chapter lists the part list, circuit diagram, and layout drawing of spectrum analyzer.
8. REPLACEABLE MECHANICAL PARTS	This chapter lists the mechanical part table of spectrum analyzer.

R3261/3361
SPECTRUM ANALYZER
MAINTENANCE MANUAL

1.2 Overview

1.2 Overview

The R3261/3361 Series spectrum analyzer, which employs a synthesized local oscillator for assuring highly stable spectrum analyzer, features wide frequency range from 9kHz to 2.6GHz (R3261A,C/AN,CN, R3361A,C/AN,CN), 9kHz to 3.6GHz (R3261B/D, R3361B/D), wide input range from -130dBm to +25dBm (R3261A,C/B,D, R3361A,C/B,D), -19dBu to +132dBu (R3261AN/CN, R3361AN/CN), wide measurement display range of 115dB and high resolution of 30Hz, low residual FM of 20Hz_{p-p}, less noise sideband of -105dBc/Hz (20kHz output from carrier) as well as full remote-control GPIB, and the memory card function for saving/recalling data and panel settings.

The R3361 contains a tracking generator that facilitates frequency characteristic measurement.

Features

- ① This analyzer permits sweeping over a wide frequency range from 9kHz to 3.6GHz (R3261B/D, R3361B/D).
- ② A maximum frequency resolution of 30Hz enables analysis of adjacent signals and spurious response.
- ③ High-precision frequency measurement
A reference crystal oscillator with an aging rate of 2×10^{-8} /day is installed to measure very weak signals (which cannot be measured by any counter) at a resolution of 1Hz in the counter mode.
- ④ Use of a memory card permits saving/recalling of front panel settings.
- ⑤ The field strength can be viewed and read directly after compensating the antenna calibration coefficient and that the QR value based on the CISPR standard can be observed directly.
- ⑥ Various enhanced functions supported by digital indications
Brief information needed for spectrum analysis is displayed on the CRT together with signal traces. The digital memory screen provides flickerless display. Various marker functions assures accurate and easy reading even in the manual mode.
- ⑦ Two channels of completely independent digital memories enable simultaneous display of two screens.
- ⑧ A full-remote-control GPIB is used as a powerful system component.
- ⑨ The built-in tracking generator of the R3361 enables direct viewing of frequency attenuation of 115dB or more.

2. SPECIFICATIONS

This chapter lists the R3261A/C, R3261AN/CN, R3261B/D, R3361A/C, R3361AN/CN, and R3361B/D specifications and accessories.

2.1 R3261A/C Specifications

(1) Frequency Specifications

Measurable bandwidth	: 9kHz to 2.6GHz
Center frequency setting increment	: 1Hz
Center frequency indication accuracy	: $\pm(3\%$ of the span + center frequency x reference oscillator accuracy + 20Hz) (span \leq 2MHz) $\pm(2\%$ of the span + center frequency x reference oscillator accuracy + 50kHz) (span > 2MHz)
Reference oscillator	: Internal or external input (10MHz)
Internal reference oscillator accuracy	
Aging	: $\pm(2 \times 10^{-8}$ per day) $\pm(1 \times 10^{-7}$ per year)
Temperature stability	: $\pm 5 \times 10^{-8}$ (from 0°C to +50°C, +25°C as a reference)
Frequency span	
LIN mode	: 1kHz to 2.6GHz, and 0
LOG mode	: 1, 2, or 3 decades of span can be selected within the range from 10kHz to 1000MHz.
Frequency span accuracy	
LIN mode	: $\pm 3\%$ of the span (span > 2MHz) $\pm 5\%$ of the span (span \leq 2MHz)
Frequency stability	
Residual FM	: 50kHz p-p or less (span > 10MHz) 2kHz p-p or less (10MHz \geq span > 2MHz) 20Hz p-p or less (span \leq 2MHz)
Frequency drift	: 300Hz/min. or less (span \leq 2MHz, at a constant temperature after an hour of warming up)
Side band noise	: ≤ -105 dBc/Hz (20kHz offset)
Resolution	
3dB bandwidth	: 30Hz to 1MHz, switched at 1 to 3 steps

R3261/3361
SPECTRUM ANALYZER
MAINTENANCE MANUAL

2.1 R3261A/C Specifications

6dB bandwidth	: 200Hz, 9kHz, 120kHz
Selectivity	: ≤ 15 : 1 (60dB : 3dB)
Bandwidth accuracy	: $\pm 20\%$
Marker accuracy	
Normal mode	: Center frequency indication accuracy + span accuracy
Counter mode	: Indicated frequency x reference oscillator accuracy ± 1 count

(2) Amplitude Specifications

Amplitude measurement range	: -130dBm to +25dBm
Screen display range	
LOG mode	: 120dB (10dB/div) : 80dB (10dB/div) : 50dB (5dB/div) : 20dB (2dB/div) : 10dB (1dB/div)
LIN mode	: 10div
QP mode	: 80dB (10dB/div) Provided the measurement range is 70dB
Linearity display	
LOG mode	: ± 2.0 dB/110dB, ± 1.5 dB/70dB, ± 1.0 dB/10dB, ± 0.2 dB/1dB
LIN mode	: $\pm 5\%$ of the fullscale
QP mode	: ± 2.0 dB/70dB, ± 1.0 dB/40dB
Reference level indication range	: -109.9dBm to +40.0dBm 0.715 μ V to 22.4V
Reference level accuracy	: ± 0.3 dB 0 to -50dBm ± 0.7 dB +20 to -70dBm
Dynamic range	
Average noise level	: -121dBm + 1.55f(GHz)dB (Resolution bandwidth 300Hz, video bandwidth 1Hz, input attenuator 0dB, frequency 1MHz or more)
Secondary, tertiary distortion	: ≤ -70 dB -30dBm input (Input attenuator 0dB, frequency 10MHz or more)
Frequency response	: ± 0.5 dB 100kHz to 2GHz ± 1.0 dB 9kHz to 2.6GHz (LOG mode, input attenuator 10dB, 20 to 30°C)

R3261/3361
SPECTRUM ANALYZER
MAINTENANCE MANUAL

2.1 R3261A/C Specifications

- Residual response : $\leq -100\text{dBm}$ (Input attenuator 0dB, 50 Ω terminator, frequency 500kHz or more)
- Resolution bandwidth switching accuracy:
: $\pm 0.3\text{dB}$ (after automatic calibration)
- Video filter : 1Hz to 1MHz (switched 1 to 10 steps)
- (3) Sweep Specifications
- Sweep time : 30msec to 1000sec and Manual sweeping
- Sweep time accuracy : $\leq 3\%$
- Trigger mode : FREE RUN, LINE, VIDEO, EXT, TV-V, SINGLE
- (4) Input Specifications
- Input impedance : Approx. 50 Ω
VSWR ≤ 1.5 (100kHz $\leq f \leq 2\text{GHz}$)
VSWR ≤ 2.0 (9kHz $\leq f \leq 2.6\text{GHz}$)
(Input attenuator $\geq 10\text{dB}$)
- Input connector : N connector
- Maximum input level : +25dBm (input attenuator $\geq 30\text{dB}$)
 $\pm 50\text{VDC max}$
- Input attenuator : 0 to 50dB (10dB steps)
- Input attenuator switching accuracy
: $\pm 1.0\text{dB}$ ($\leq 2.0\text{GHz}$)
 $\pm 1.5\text{dB}$ ($\leq 2.6\text{GHz}$)
(Input attenuator 10dB standard)
- Detection mode : NORMAL, POSI, NEGA, SAMPLE
- (5) Output Specifications
- External memory function : IC memory card
- Video output : Approx. 1Vp-p, approx 75 Ω , composite
- Sound monitor output : The AM and FM sound can be monitored with an approximately 8 Ω earphone.
- Power supply for probes : $\pm 15\text{V}$, 4-pin connector
- Recorder output : X axis approx. -5 to +5V, output impedance approx. 10k Ω
Y axis approx. 0 to +4V, output impedance approx. 220 Ω

R3261/3361
SPECTRUM ANALYZER
MAINTENANCE MANUAL

2.1 R3261A/C Specifications

- GPIB data output/
Remote control : The built-in GPIB interface allows data output and remote control.
- Direct plot : Also, the built-in GPIB interface allows an output of on-screen data to the R9833 plotter to have a hardcopy.
- Printer output : The built-in GPIB interface allows HP2225AJ to output a hard copy of on-screen data.

(6) Indication Specifications

- Indicated items : Waveforms, setting conditions, grid, label
- CRT display unit : 5.5 inch
- Trace : Two screens of A and B
- WRITE : Signal response from the analyzer is indicated at every sweeping.
- VIEW : The WRITE waveform contained in the memory, or other contents in the memory are displayed.
- MAX HOLD : Indication of the maximum signal level of repeat sweeping
- AVG : Indication of the average of repeat sweeping

(7) Other functions (R3261C only)

Occupied bandwidth measurement/Adjacent channel leakage power measurement

Multi-marker function

(8) General Specifications

- Using ambient condition : 0 to 50°C
85%RH or less
- Storage temperature range : -20 to +60°C

R3261/3361
SPECTROM ANALYZER
MAINTENANCE MANUAL

2.1 R3261A/C Specifications

Power supply : The power voltage of the analyzer is set at the delivery according to the customer's ordering information.

Option No.	Standard	44
Line voltage (V)	90 to 132	198 to 250

48 to 66Hz

R3261C : Line voltage range 90 to 132VAC or 198 to 250VAC is automatically selected internally.
48 to 66Hz

Power consumption : 220VA or less

Dimensions : Approx. 330(W) x 177(H) x 450(D) mm

Mass : Approx. 15kg

(9) Options and Accessories

Option

- OPTION 02 RS-232 interface
- OPTION 04 Occupied bandwidth measurement/Adjacent channel leakage power measurement
- OPTION 12 Gated sweep function
- OPTION 15 Controller function
(Parallel I/O, Serial I/O)
- OPTION 70 Multi-marker function
- OPTION 72 Printer output
- OPTION 80 RS-232 interface/Gated sweep function
- OPTION 81 Controller function/Gated sweep function

Separate accessory

- R3551 EMI preselector
- R16211 Carrying case
- A02804 Front cover
- A09505 Memory card (32k byte, 5 pieces)
- A09506 Memory card (128k byte, 5 pieces)
- A02034 Panel Mount Kits
- A02255 Rack Mount Kits (JIS)
- A02455 Rack Mount Kits (EIA)

R3261/3361
SPECTRUM ANALYZER
MAINTENANCE MANUAL

2.2 R3261AN/CN Specifications

2.2R3261AN/CN Specifications

(1) Frequency Specifications

Measurable bandwidth	: 9kHz to 2.6GHz
Center frequency setting increment	: 1Hz
Center frequency indication accuracy	: $\pm(3\%$ of the span + center frequency x reference oscillator accuracy + 20Hz) (span \leq 2MHz) $\pm(2\%$ of the span + center frequency x reference oscillator accuracy + 50kHz) (span > 2MHz)
Reference oscillator	: Internal or external input (10MHz)
Internal reference oscillator accuracy	
Aging	: $\pm(2 \times 10^{-8}$ per day) $\pm(1 \times 10^{-7}$ per year)
Temperature stability	: $\pm 5 \times 10^{-8}$ (from 0°C to +50°C, +25°C as a reference)
Frequency span	
LIN mode	: 1kHz to 2.6GHz, and 0
LOG mode	: 1, 2, or 3 decades of span can be selected within the range from 10kHz to 1000MHz.
Frequency span accuracy	
LIN mode	: $\pm 3\%$ of the span (span > 2MHz) $\pm 5\%$ of the span (span \leq 2MHz)
Frequency stability	
Residual FM	: 50kHz p-p or less (span > 10MHz) 2kHz p-p or less (10MHz \geq span > 2MHz) 20Hz p-p or less (span \leq 2MHz)
Frequency drift	: 300Hz/min. or less (span \leq 2MHz, at a constant temperature after an hour of warming up)
Side band noise	: ≤ -105 dBc/Hz (20kHz offset)
Resolution	
3dB bandwidth	: 30Hz to 1MHz, switched at 1 to 3 steps
6dB bandwidth	: 200Hz, 9kHz, 120kHz
Selectivity	: ≤ 15 : 1 (60dB : 3dB)
Bandwidth accuracy	: $\pm 20\%$

R3261/3361
SPECTRUM ANALYZER
MAINTENANCE MANUAL

2.2 R3261AR/CN Specifications

Marker accuracy	
Normal mode	: Center frequency indication accuracy + span accuracy
Counter mode	: Indicated frequency x reference oscillator accuracy ± 1 count

(2) Amplitude Specifications

Amplitude measurement range	: -19dBu to +132dBu
Screen display range	
LOG mode	: 120dB (10dB/div) : 80dB (10dB/div) : 50dB (5dB/div) : 20dB (2dB/div) : 10dB (1dB/div)
LIN mode	: 10div
QP mode	: 80dB (10dB/div) Provided the measurement range is 70dB
Linearity display	
LOG mode	: ± 2.0 dB/110dB, ± 1.5 dB/70dB, ± 1.0 dB/10dB, ± 0.2 dB/1dB
LIN mode	: $\pm 5\%$ of the fullscale
QP mode	: ± 2.0 dB/70dB, ± 1.0 dB/40dB
Reference level indication range	: +0.1dBu to +150dBu 1.01 μ V to 31.6V
Reference level accuracy	: ± 0.3 dB +110 to +60dBu ± 0.7 dB +130 to +40dBu
Dynamic range	
Average noise level	: -10dBu + 1.55f(GHz)dB (Resolution bandwidth 300Hz, video bandwidth 1Hz, input attenuator 0dB, frequency 1MHz or more)
Secondary, tertiary distortion	: ≤ -70 dB -30dBm input (Input attenuator 0dB, frequency 10MHz or more)
Frequency response	: ± 0.5 dB 100kHz to 2GHz ± 1.5 dB 9kHz to 2.6GHz (LOG mode, input attenuator 10dB, 20 to 30°C)
Residual response	: $\leq +11$ dBu (Input attenuator 0dB, 75 Ω terminator, frequency 500kHz or more)

R3261/3361
SPECTRUM ANALYZER
MAINTENANCE MANUAL

2.2 R3261AN/CN Specifications

- Resolution bandwidth switching accuracy : $\pm 0.3\text{dB}$ (after automatic calibration)
- Video filter : 1Hz to 1MHz (switched 1 to 10 steps)
- (3) Sweep Specifications
- Sweep time : 30msec to 1000sec and Manual sweeping
- Sweep time accuracy : $\leq 3\%$
- Trigger mode : FREE RUN, LINE, VIDEO, EXT, TV-V, SINGLE
- (4) Input Specifications
- Input impedance : Approx. 75 Ω
VSWR ≤ 1.5 (100kHz $\leq f \leq$ 2GHz)
VSWR ≤ 2.0 (9kHz $\leq f \leq$ 2.6GHz)
(Input attenuator $\geq 10\text{dB}$)
- Input connector : N connector
- Maximum input level : +132dBu (input attenuator $\geq 30\text{dB}$)
 $\pm 50\text{VDC max}$
- Input attenuator : 0 to 50dB (10dB steps)
- Input attenuator switching accuracy : $\pm 1.0\text{dB}$ ($\leq 2.0\text{GHz}$)
 $\pm 1.5\text{dB}$ ($\leq 2.6\text{GHz}$)
(Input attenuator 10dB standard)
- Detection mode : NORMAL, PEAK, NEG, SAMPLE
- (5) Output Specifications
- External memory function : IC memory card
- Video output : Approx. 1Vp-p, approx 75 Ω , composite
- Sound monitor output : The AM and FM sound can be monitored with an approximately 8 Ω earphone.
- Power supply for probes : $\pm 15\text{V}$, 4-pin connector
- Recorder output : X axis approx. -5 to +5V, output impedance approx. 10k Ω
Y axis approx. 0 to +4V, output impedance approx. 220 Ω

R3261/3361
SPECTRUM ANALYSER
MAINTENANCE MANUAL

2.2 R3261AN/CN Specifications

GPIB data output/ Remote control	: The built-in GPIB interface allows data output and remote control.
Direct plot	: Also, the built-in GPIB interface allows an output of on-screen data to the R9833 plotter to have a hardcopy.
Printer output	: The built-in GPIB interface allows HP2225AJ to output a hard copy of on-screen data.

(6) Indication Specifications

Indicated items	: Waveforms, setting conditions, grid, label
CRT display unit	: 5.5 inch
Trace	: Two screens of A and B
WRITE	: Signal response from the analyzer is indicated at every sweeping.
VIEW	: The WRITE waveform contained in the memory, or other contents in the memory are displayed.
MAX HOLD	: Indication of the maximum signal level of repeat sweeping
AVG	: Indication of the average of repeat sweeping

(7) Other functions (R3261CN only)

Occupied bandwidth measurement/Adjacent channel leakage power measurement

Multi-marker function

(8) General Specifications

Using ambient condition	: 0 to 50°C 85%RH or less
Storage temperature range	: -20 to +60°C

R3261/3361
SPECTRUM ANALYZER
MAINTENANCE MANUAL

2.2 R3261AM/CN Specifications

Power supply : The power voltage of the analyzer is set at the delivery according to the customer's ordering information.

Option No.	Standard	44
Line voltage (V)	90 to 132	198 to 250

48 to 66Hz

R3261CN : Line voltage range 90 to 132VAC or 198 to 250VAC is automatically selected internally.
48 to 66Hz

Power consumption : 220VA or less

Dimensions : Approx. 330(W) x 177(H) x 450(D) mm

Mass : Approx. 15kg

(9) Options and Accessories

Option

- OPTION 02 RS-232 interface
- OPTION 04 Occupied bandwidth measurement/Adjacent channel leakage power measurement
- OPTION 12 Gated sweep function
- OPTION 15 Controller function
(Parallel I/O, Serial I/O)
- OPTION 70 Multi-marker function
- OPTION 72 Printer output
- OPTION 80 RS-232 interface/Gated sweep function
- OPTION 81 Controller function/Gated sweep function

Separate accessory

- R3551 EMI preselector
- R16211 Carrying case
- A02804 Front cover
- A09505 Memory card (32k byte, 5 pieces)
- A09506 Memory card (128k byte, 5 pieces)
- A02034 Panel Mount Kits
- A02255 Rack Mount Kits (JIS)
- A02455 Rack Mount Kits (EIA)

R3261/3361
SPECTRUM ANALYZER
MAINTENANCE MANUAL

2.3 R3261B/D Specifications

2.3 R3261B/D Specifications

(1) Frequency Specifications

Measurable bandwidth	: 9kHz to 3.6GHz
Center frequency setting increment	: 1Hz
Center frequency indication accuracy	: $\pm(3\%$ of the span + center frequency x reference oscillator accuracy + 20Hz) (span \leq 2MHz) $\pm(2\%$ of the span + center frequency x reference oscillator accuracy + 50kHz) (span > 2MHz)
Reference oscillator	: Internal or external input (10Hz)
Internal reference oscillator accuracy	
Aging	: $\pm(2 \times 10^{-8}$ per day) $\pm(1 \times 10^{-7}$ per year)
Temperature stability	: $\pm 5 \times 10^{-8}$ (from 0°C to +50°C, +25°C as a reference)
Frequency span	
LIN mode	: 1kHz to 3.6GHz and 0
LOG mode	: 1, 2, or 3 decades of span can be selected within the range from 10kHz to 1000MHz.
Frequency span accuracy	
LIN mode	: $\pm 3\%$ of the span (span > 2MHz) $\pm 5\%$ of the span (span \leq 2MHz)
Frequency stability	
Residual FM	: 50kHz p-p or less (span > 10MHz) 2kHz p-p or less (10MHz \geq span > 2MHz) 20Hz p-p or less (span \leq 2MHz)
Frequency drift	: 300Hz/min. or less (span \leq 2MHz, at a constant temperature after an hour of warming up)
Side band noise	: ≤ -105 dBc/Hz $f \leq 3.0$ GHz ≤ -101 dBc/Hz $f \leq 3.6$ GHz (20kHz offset)
Resolution	
3dB bandwidth	: 30Hz to 1MHz, switched 1 to 3 steps
6dB bandwidth	: 200Hz, 9kHz, 120kHz
Selectivity	: ≤ 15 : (60dB : 3dB)
Bandwidth accuracy	: $\pm 20\%$

R3261/3361
SPECTRUM ANALYZER
MAINTENANCE MANUAL

2.3 R3261B/D Specifications

Marker accuracy	
Normal mode	: Center frequency indication accuracy + span accuracy
Counter mode	: Indicated frequency x reference oscillator accuracy ± 1 count

(2) Amplitude Specifications

Amplitude measurement range	: -130dBm to +25dBm
Screen display range	
LOG mode	: 120dB (10dB/div) : 80dB (10dB/div) : 50dB (5dB/div) : 20dB (2dB/div) : 10dB (1dB/div)
LIN mode	: 10div
QP mode	: 80dB (10dB/div) Provided the measurement range is 70dB
Linearity display	
LOG mode	: ± 2.0 dB/110dB, ± 1.5 dB/70dB, ± 1.0 dB/10dB, ± 0.2 dB/1dB
LIN mode	: $\pm 5\%$ of the fullscale
QP mode	: ± 2.0 dB/70dB, ± 1.0 dB/40dB
Reference level indication range	: -109.9dBm to +40.0dBm 0.715 μ V to 22.4V
Reference level accuracy	: ± 0.3 dB 0 to -50dBm ± 0.7 dB +20 to -70dBm
Dynamic range	
Average noise level	: -121dBm + 1.55f(GHz)dB (Resolution bandwidth 300Hz, video bandwidth 1Hz, input attenuator 0dB, frequency 1MHz or more)
Secondary, tertiary distortion	: ≤ -70 dB -30dBm input (Input attenuator 0dB, frequency 10MHz or more)
Frequency response	: ± 0.5 dB 100kHz to 2GHz ± 1.0 dB 9kHz to 3.6GHz (LOG mode, input attenuator 10dB, 20 to 30°C)
Residual response	: ≤ -100 dBm (Input attenuator 0dB, 50 Ω terminator, frequency 500kHz or more)

R3261/3361
SPECTRUM ANALYSER
MAINTENANCE MANUAL

2.3 R3261B/D Specifications

- Resolution bandwidth switching accuracy : $\pm 0.3\text{dB}$ (after automatic calibration)
- Video filter : 1Hz to 1MHz (switched 1 to 10 steps)
- (3) Sweep Specifications
- Sweep time : 30msec to 1000sec and Manual sweeping
- Sweep time accuracy : $\leq 3\%$
- Trigger mode : FREE RUN, LINE, VIDEO, EXT, TV-V, SINGLE
- (4) Input Specifications
- Input impedance : Approx. 50 Ω
VSWR ≤ 1.5 (100kHz $\leq f \leq 2\text{GHz}$)
VSWR ≤ 2.0 (9kHz $\leq f \leq 3.6\text{GHz}$)
(Input attenuator $\geq 10\text{dB}$)
- Input connector : N connector
- Maximum input level : +25dBm (input attenuator $\geq 30\text{dB}$)
 $\pm 50\text{VDC max}$
- Input attenuator : 0 to 50dB (10dB steps)
- Input attenuator switching accuracy : $\pm 1.0\text{dB}$ ($\leq 2.0\text{GHz}$)
 $\pm 1.5\text{dB}$ ($\leq 3.6\text{GHz}$)
(Input attenuator 10dB standard)
- Detection mode : NORMAL, POSI, NEGA, SAMPLE
- (5) Output Specifications
- External memory function : IC memory card
- Video output : Approx. 1Vp-p, approx 75 Ω , composite
- Sound monitor output : The AM and FM sound can be monitored with an approximately 8 Ω earphone.
- Power supply for probes : $\pm 15\text{V}$, 4-pin connector
- Recorder output : X axis approx. -5 to +5V, output impedance approx. 10k Ω
Y axis approx. 0 to +4V, output impedance approx. 220 Ω

R3261/3361
SPECTRUM ANALYSER
MAINTENANCE MANUAL

2.3 R3261B/D Specifications

GPIB data output/ Remote control	: The built-in GPIB interface allows data output and remote control.
Direct plot	: Also, the built-in GPIB interface allows an output of on-screen data to the R9833 plotter to have a hardcopy.
Printer output	: The built-in GPIB interface allows HP2225AJ to output a hard copy of on-screen data.

(6) Indication Specifications

Indicated items	: Waveforms, setting conditions, grid, label
CRT display unit	: 5.5 inch
Trace	: Two screens of A and B
WRITE	: Signal response from the analyzer is indicated at every sweeping.
VIEW	: The WRITE waveform contained in the memory, or other contents in the memory are displayed.
MAX HOLD	: Indication of the maximum signal level of repeat sweeping
AVG	: Indication of the average of repeat sweeping

(7) Other functions (R3261D only)

Occupied bandwidth measurement/Adjacent channel leakage power measurement

Multi-marker function

(8) General Specifications

Using ambient condition	: 0 to 50°C 85%RH or less
Storage temperature range	: -20 to +60°C

R3261/3361
SPECTRUM ANALYZER
MAINTENANCE MANUAL

2.3 R3261B/D Specifications

Power supply : The power voltage of the analyzer is set at the delivery according to the customer's ordering information.

Option No.	Standard	44
Line voltage (V)	90 to 132	198 to 250

48 to 66Hz

R3261D : Line voltage range 90 to 132VAC or 198 to 250VAC is automatically selected internally.
48 to 66Hz

Power consumption : 220VA or less

Dimensions : Approx. 330(W) x 177(H) x 450(D) mm

Mass : Approx. 15kg

(9) Options and Accessories

Option

- OPTION 02 RS-232 interface
- OPTION 04 Occupied bandwidth measurement/Adjacent channel leakage power measurement
- OPTION 12 Gated sweep function
- OPTION 15 Controller function
(Parallel I/O, Serial I/O)
- OPTION 70 Multi-marker function
- OPTION 72 Printer output
- OPTION 80 RS-232 interface/Gated sweep function
- OPTION 81 Controller function/Gated sweep function

Separate accessory

- R3551 EMI preselector
- R16211 Carrying case
- A02804 Front cover
- A09505 Memory card (32k byte, 5 pieces)
- A09506 Memory card (128k byte, 5 pieces)
- A02034 Panel Mount Kits
- A02255 Rack Mount Kits (JIS)
- A02455 Rack Mount Kits (EIA)

2.4R3361A/C Specifications

(1) Frequency Specifications

Measurable bandwidth	: 9kHz to 2.6GHz
Center frequency setting increment	: 1Hz
Center frequency indication accuracy	: $\pm(3\%$ of the span + center frequency x reference oscillator accuracy + 20Hz) (span \leq 2MHz) $\pm(2\%$ of the span + center frequency x reference oscillator accuracy + 50kHz) (span > 2MHz)
Reference oscillator	: Internal or external input (10MHz)
Internal reference oscillator accuracy	
Aging	: $\pm(2 \times 10^{-8}$ per day) $\pm(1 \times 10^{-7}$ per year)
Temperature stability	: 15×10^{-8} (from 0°C to +50°C, +25°C as a reference)
Frequency span	
LIN mode	: 1kHz to 2.6GHz and 0
LOG mode	: 1, 2, or 3 decades of span can be selected within the range from 10kHz to 1000MHz.
Frequency span accuracy	
LIN mode	: $\pm 3\%$ of the span (span > 2MHz) $\pm 5\%$ of the span (span \leq 2MHz)
Frequency stability	
Residual FM	: 50kHz p-p or less (span > 10MHz) 2kHz p-p or less (10MHz \geq span > 2MHz) 20Hz p-p or less (span \leq 2MHz)
Frequency drift	: 300Hz/min. or less (span \leq 2MHz, at a constant temperature after an hour of warming up)
Side band noise	: ≤ -105 dBc/Hz (20kHz offset)
Resolution	
3dB bandwidth	: 30Hz to 1MHz, switched 1 to 3 steps
6dB bandwidth	: 200Hz, 9kHz, 120kHz
Selectivity	: $\leq 15: 1$ (60dB : 3dB)
Bandwidth accuracy	: $\pm 2\%$

R3261/3361
SPECTRUM ANALYZER
MAINTENANCE MANUAL

2.4 R3361A/C Specifications

Marker accuracy	
Normal mode	: Center frequency indication accuracy + span accuracy
Counter mode	: Indicated frequency x reference oscillator accuracy ± 1 count (Excepting TG mode)

(2) Amplitude Specifications

Amplitude measurement range	: -130dBm to +25dBm
Screen display range	
LOG mode	: 120dB (10dB/div) : 80dB (10dB/div) : 50dB (5dB/div) : 20dB (2dB/div) : 10dB (1dB/div)
LIN mode	: 10div
QP mode	: 80dB (10dB/div) Provided the measurement range is 70dB
Linearity display	
LOG mode	: ± 2.0 dB/110dB, ± 1.5 dB/70dB, ± 1.0 dB/10dB, ± 0.2 dB/1dB
LIN mode	: $\pm 5\%$ of the fullscale
QP mode	: ± 2.0 dB/70dB, ± 1.0 dB/40dB
Reference level indication range	: -109.9dBm to +40.0dBm 0.715 μ V to 22.4V
Reference level accuracy	: ± 0.3 dB 0 to -50dBm ± 0.7 dB +20 to -70dBm
Dynamic range	
Average noise level	: -121dBm + 1.55f(GHz)dB (Resolution bandwidth 300Hz, video bandwidth 1Hz, input attenuator 0dB, frequency 1MHz or more)
Secondary, tertiary distortion	: ≤ -70 dB -30dBm input (Input attenuator 0dB, frequency 10MHz or more)
Frequency response	: ± 0.5 dB 100kHz to 2GHz ± 1.0 dB 9kHz to 2.6GHz (LOG mode, input attenuator 10dB, 20 to 30°C)
Residual response	: ≤ -100 dBm (Input attenuator 0dB, 50 Ω terminator, frequency 500kHz or more)

R3261/3361
SPECTRUM ANALYSER
MAINTENANCE MANUAL

2.4 R3361A/C Specifications

- Resolution bandwidth switching accuracy
: $\pm 0.3\text{dB}$ (after automatic calibration)
- Video filter
: 1Hz to 1MHz (switched 1 to 10 steps)
- (3) Sweep Specifications
- Sweep time
: 30msec to 1000sec and Manual sweeping
- Sweep time accuracy
: $\leq 3\%$
- Trigger mode
: FREE RUN, LINE, VIDEO, EXT, TV-V, SINGLE
- (4) Input Specifications
- Input impedance
: Approx. 50Ω
VSWR ≤ 1.5 ($100\text{kHz} \leq f \leq 2\text{GHz}$)
VSWR ≤ 2.0 ($9\text{kHz} \leq f \leq 2.6\text{GHz}$)
(Input attenuator $\geq 10\text{dB}$)
- Input connector
: N connector
- Maximum input level
: +25dBm (input attenuator $\geq 30\text{dB}$)
 $\pm 50\text{VDC max}$
- Input attenuator
: 0 to 50dB (10dB steps)
- Input attenuator switching accuracy
: $\pm 1.0\text{dB}$ ($\leq 2.0\text{GHz}$)
 $\pm 1.5\text{dB}$ ($\leq 2.6\text{GHz}$)
(Input attenuator 10dB standard)
- Detection mode
: NORMAL, POSI, NEGA, SAMPLE
- (5) Tracking generator specifications
- Frequency range
: 9kHz to 2.6GHz
- Output level range
: 0dBm to -50dBm Setting can be done in
steps of 1dB.
- Output level accuracy
: $\pm 0.5\text{dB}$ (30MHz, -10dBm, +20 to +30°C)
- Output level flatness
: $\pm 0.7\text{dB}$ (100kHz to 1.0GHz)
 $\pm 1.5\text{dB}$ (9kHz to 2.6GHz)
(-10dBm output)

R3261/3361
SPECTRUM ANALYZER
MAINTENANCE MANUAL

2.4 R3361A/C Specifications

Output level switching accuracy	: $\pm 1.0\text{dB}$ (100kHz to 1.0GHz) : $\pm 2.0\text{dB}$ (9kHz to 2.6GHz) : (-10dBm reference)
Output spuriousness	: Harmonics spurious level $\leq -20\text{dB}$: Non-harmonics spurious level $\leq -30\text{dB}$: (Output level 0dBm)
TG leakage	: $\leq -110\text{dBm}$
Output impedance	: Approx. 50 Ω
Output VSWR	: ≤ 1.5 (100kHz to 2.0GHz) : ≤ 2.0 (9kHz to 2.6GHz) : (At $\leq -10\text{dBm}$ output)
Output connector	: N-connector
(6) Output Specifications	
External memory function:	IC memory card
Video output	: Approx. 1Vp-p, approx. 75 Ω , composite
Sound monitor output	: The AM and FM sound can be monitored with an approximately 8 Ω earphone.
Power supply for probes	: $\pm 15\text{V}$, 4-pin connector
Recorder output	: X axis approx. -5 to +5V, output impedance approx. 10k Ω Y axis approx. 0 to +4V, output impedance approx. 220 Ω
GPIS data output/ Remote control	: The built-in GPIS interface allows data output and remote control.
Direct plot	: Also, the built-in GPIS interface allows an output of on-screen data to the R9833 plotter to have a hardcopy.
Printer output	: The built-in GPIS interface allows HP2225AJ to output a hard copy of on-screen data.

R3261/3361
SPECTRUM ANALYZER
MAINTENANCE MANUAL

2.4 R3361A/C Specifications

(7) Indication Specifications

Indicated items : Waveforms, setting conditions, grid, label
CRT display unit : 5.5 inch
Trace : Two screens of A and B
WRITE : Signal response from the analyzer is indicated at every sweeping.
VIEW : The WRITE waveforms contained in the memory, or other contents in the memory are displayed.
MAX HOLD : Indication of maximum signal level during repeated sweeping
AVG : Indication of average signal level during repeated sweeping

(8) Other functions (R3361C only)

Occupied bandwidth measurement/Adjacent channel leakage power measurement
Multi-marker function

(9) General Specifications

Using ambient condition : 0 to 50°C
85%RH or less
Storage temperature range : -20 to +60°C
Power supply : The power voltage of the analyzer is set at the delivery according to the customer's ordering information.

Option No.	Standard	44
Line voltage (V)	90 to 132	198 to 250

48 to 66Hz

R3361C : Line voltage range 90 to 132VAC or 198 to 250VAC is automatically selected internally.
48 to 66Hz

R3261/3361
SPECTRUM ANALYSER
MAINTENANCE MANUAL

2.4 R3361A/C Specifications

Power consumption : 220VA or less
Dimensions : Approx. 330(W) x 177(H) x 450(D) mm
Mass : Approx. 17kg

(10) Options and Accessories

Option

OPTION 02 RS-232 interface
OPTION 04 Occupied bandwidth measurement/Adjacent channel leakage
power measurement
OPTION 12 Gated sweep function
OPTION 15 Controller function
(Parallel I/O, Serial I/O)
OPTION 70 Multi-marker function
OPTION 72 Printer output
OPTION 80 RS-232 interface/Gated sweep function
OPTION 81 Controller function/Gated sweep function

Separate accessory

R3551 EMI preselector
R16211 Carrying case
A02804 Front cover
A09505 Memory card (32k byte, 5 pieces)
A09506 Memory card (128k byte, 5 pieces)
A02034 Panel Mount Kits
A02255 Rack Mount Kits (JIS)
A02455 Rack Mount Kits (EIA)

2.5R3361AN/CN Specifications

(1) Frequency Specifications

Measurable bandwidth	: 9kHz to 2.6GHz
Center frequency setting increment	: 1Hz
Center frequency indication accuracy	: $\pm(3\%$ of the span + center frequency x reference oscillator accuracy + 20Hz) (span \leq 2MHz) $\pm(2\%$ of the span + center frequency x reference oscillator accuracy + 50kHz) (span > 2MHz)
Reference oscillator	: Internal or external input (10MHz)
Internal reference oscillator accuracy	
Aging	: $\pm(2 \times 10^{-8}$ per day) $\pm(1 \times 10^{-7}$ per year)
Temperature stability	: $\pm 5 \times 10^{-8}$ (from 0°C to +50°C, +25°C as a reference)
Frequency span	
LIN mode	: 1kHz to 2.6GHz and 0
LOG mode	: 1, 2, or 3 decades of span can be selected within the range from 10kHz to 1000MHz.
Frequency span accuracy	
LIN mode	: $\pm 3\%$ of the span (span > 2MHz) $\pm 5\%$ of the span (span \leq 2MHz)
Frequency stability	
Residual FM	: 50kHz p-p or less (span > 10MHz) 2kHz p-p or less (10MHz \geq span > 2MHz) 20Hz p-p or less (span \leq 2MHz)
Frequency drift	: 300Hz/min. or less (span \leq 2MHz, at a constant temperature after an hour of warming up)
Side band noise	: ≤ -105 dBc/Hz (20kHz offset)
Resolution	
3dB bandwidth	: 30Hz to 1MHz, switched 1 to 3 steps
6dB bandwidth	: 200Hz, 9kHz, 120kHz
Selectivity	: ≤ 15 : 1 (60dB : 3dB)
Bandwidth accuracy	: $\pm 20\%$

R3261/3361
SPECTRUM ANALYZER
MAINTENANCE MANUAL

2.5 R3361AN/CN Specifications

Marker accuracy	
Normal mode	: Center frequency indication accuracy + span accuracy
Counter mode	: Indicated frequency x reference oscillator accuracy ± 1 count (Excepting TG mode)

(2) Amplitude Specifications

Amplitude measurement range	: -19dBu to +132dBu
Screen display range	
LOG mode	: 120dB (10dB/div) : 80dB (10dB/div) : 50dB (5dB/div) : 20dB (2dB/div) : 10dB (1dB/div)
LIN mode	: 10div
QP mode	: 80dB (10dB/div) Provided the measurement range is 70dB
Linearity display	
LOG mode	: ± 2.0 dB/110dB, ± 1.5 dB/70dB, ± 1.0 dB/10dB, ± 0.2 dB/1dB
LIN mode	: $\pm 5\%$ of the fullscale
QP mode	: ± 2.0 dB/70dB, ± 1.0 dB/40dB
Reference level indication range	: +0.1dBu to +150dBu 1.0 μ V to 31.6V
Reference level accuracy	: ± 0.3 dB +110 to +60dBu ± 0.7 dB +130 to +40dBu
Dynamic range	
Average noise level	: -10dBu + 1.55f(GHz)dB (Resolution bandwidth 300Hz, video bandwidth 1Hz, input attenuator 0dB, frequency 1MHz or more)
Secondary, tertiary distortion	: ≤ -70 dB -30dBm input (Input attenuator 0dB, frequency 10MHz or more)
Frequency response	: ± 0.5 dB 100kHz to 2GHz ± 1.5 dB 9kHz to 2.6GHz (LOG mode, input attenuator 10dB, 20 to 30°C)
Residual response	: $\leq +11$ dBu (Input attenuator 0dB, 75 Ω terminator, frequency 500kHz or more)

R3261/3361
SPECTRUM ANALYSER
MAINTENANCE MANUAL

2.5 R3361AN/CN Specifications

- Resolution bandwidth switching accuracy
: $\pm 0.3\text{dB}$ (after automatic calibration)
- Video filter
: 1Hz to 1MHz (switched 1 to 10 steps)
- (3) Sweep Specifications
- Sweep time
: 30msec to 1000sec and Manual sweeping
- Sweep time accuracy
: $\leq 3\%$
- Trigger mode
: FREE RUN, LINE, VIDEO, EXT, TV-V, SINGLE
- (4) Input Specifications
- Input impedance
: Approx. 75 Ω
VSWR ≤ 1.5 (100kHz $\leq f \leq 2\text{GHz}$)
VSWR ≤ 2.0 (9kHz $\leq f \leq 2.6\text{GHz}$)
(Input attenuator $\geq 10\text{dB}$)
- Input connector
: N connector
- Maximum input level
: +132dB μ (input attenuator $\geq 30\text{dB}$)
 $\pm 50\text{VDC max}$
- Input attenuator
: 0 to 50dB (10dB steps)
- Input attenuator switching accuracy
: $\pm 1.0\text{dB}$ ($\leq 2.0\text{GHz}$)
 $\pm 1.5\text{dB}$ ($\leq 2.6\text{GHz}$)
(Input attenuator 10dB standard)
- Detection mode
: NORMAL, POSI, NEG, SAMPLE
- (5) Tracking generator specifications
- Frequency range
: 9kHz to 2.6GHz
- Output level range
: 105dB μ to +55dB μ Setting can be done in
steps of 1dB.
- Output level accuracy
: $\pm 0.5\text{dB}$ (30MHz, +95dB μ , +20 to +30 $^{\circ}\text{C}$)
- Output level flatness
: $\pm 0.7\text{dB}$ (100kHz to 1.0GHz)
 $\pm 1.5\text{dB}$ (100kHz to 2.0GHz)
 $\pm 2.0\text{dB}$ (9kHz to 2.6GHz)
(+95dB μ output)

R3261/3361
SPECTRUM ANALYSER
MAINTENANCE MANUAL

2.5 R3361AN/CN Specifications

Output level switching accuracy	: $\pm 1.0\text{dB}$ (100kHz to 1.0GHz) $\pm 2.0\text{dB}$ (9kHz to 2.6GHz) (+95dBu reference)
Output spuriousness	: Harmonics spurious level $\leq -20\text{dB}$ Non-harmonics spurious level $\leq -30\text{dB}$ (Output level +105dBu)
TG leakage	: $\leq +1\text{dBu}$
Output impedance	: Approx. 75 Ω
Output VSWR	: ≤ 1.5 (100kHz to 2.0GHz) ≤ 2.0 (9kHz to 2.6GHz) (At $\leq +95\text{dBu}$ output)
Output connector	: N-connector
(6) Output Specifications	
External memory function:	IC memory card
Video output	: Approx. 1Vp-p, approx. 75 Ω , composite
Sound monitor output	: The AM and FM sound can be monitored with an approximately 8 Ω earphone.
Power supply for probes	: $\pm 15\text{V}$, 4-pin connector
Recorder output	: X axis approx. -5 to +5V, output impedance approx. 10k Ω Y axis approx. 0 to +4V, output impedance approx. 220 Ω
GPIB data output/ Remote control	: The built-in GPIB interface allows data output and remote control.
Direct plot	: Also, the built-in GPIB interface allows an output of on-screen data to the R9833 plotter to have a hardcopy.
Printer output	: The built-in GPIB interface allows HP2225AJ to output a hard copy of on-screen data.

R3261/3361
SPECTRUM ANALYSER
MAINTENANCE MANUAL

2.5 R3361AN/CN Specifications

(7) Indication Specifications

Indicated items : Waveforms, setting conditions, grid, label
CRT display unit : 5.5 inch
Trace : Two screens of A and B
WRITE : Signal response from the analyzer is indicated at every sweeping.
VIEW : The WRITE waveform contained in the memory, or other contents in the memory are displayed.
MAX HOLD : Indication of maximum signal level during repeated sweeping
AVG : Indication of average signal level during repeated sweeping

(8) Other functions (R3361CN only)

Occupied bandwidth measurement/Adjacent channel leakage power measurement
Multi-marker function

(9) General Specifications

Using ambient condition : 0 to 50°C
85%RH or less
Storage temperature range : -20 to +60°C
Power supply : The power voltage of the analyzer is set at the delivery according to the customer's ordering information.

Option No.	Standard	44
Line voltage (V)	90 to 132	198 to 250

48 to 66Hz

R3361CN : Line voltage range 90 to 132VAC or 198 to 250VAC is automatically selected internally.
48 to 66Hz

R3261/3361
SPECTRUM ANALYZER
MAINTENANCE MANUAL

2.5 R3361AN/CN Specifications

Power consumption	: 220VA or less
Dimensions	: Approx. 330(W) x 177(H) x 450(D) mm
Mass	: Approx. 17kg

(10) Options and Accessories

Option

OPTION 02	RS-232 interface
OPTION 04	Occupied bandwidth measurement/Adjacent channel leakage power measurement
OPTION 12	Gated sweep function
OPTION 15	Controller function (Parallel I/O, Serial I/O)
OPTION 70	Multi-marker function
OPTION 72	Printer output
OPTION 80	RS-232 interface/Gated sweep function
OPTION 81	Controller function/Gated sweep function

Separate accessory

R3551	EMI preselector
R16211	Carrying case
A02804	Front cover
A09505	Memory card (32k byte, 5 pieces)
A09506	Memory card (128k byte, 5 pieces)
A02034	Panel Mount Kits
A02255	Rack Mount Kits (JIS)
A02455	Rack Mount Kits (EIA)

2.6R3361B/D Specifications

(1) Frequency Specifications

Measurable bandwidth	: 9kHz to 3.6GHz
Center frequency setting increment	: 1Hz
Center frequency indication accuracy:	
	$\pm(3\%$ of the span + center frequency x reference oscillator accuracy + 20Hz) (span \geq 2MHz)
	$\pm(2\%$ of the span + center frequency x reference oscillator accuracy + 50kHz) (span \leq 2MHz)
Reference oscillator	: Internal or external input (10Hz)
Internal reference oscillator accuracy	
Aging	: $\pm(2 \times 10^{-8}$ per day) $\pm(1 \times 10^{-7}$ per year)
Temperature stability	: $\pm 5 \times 10^{-8}$ (from 0°C to +50°C, +25°C as a reference)
Frequency span	
LIN mode	: 1kHz to 3.6GHz and 0
LOG mode	: 1, 2, or 3 decades of span can be selected within the range from 10kHz to 1000MHz.
Frequency span accuracy	
LIN mode	: $\pm 3\%$ of the span (span $>$ 2MHz) $\pm 5\%$ of the span (span \leq 2MHz)
Frequency stability	
Residual FM	: 50kHz p-p or less (span $>$ 10MHz) 2kHz p-p or less (10MHz \geq span $>$ 2MHz) 20Hz p-p or less (span \leq 2MHz)
Frequency drift	: 300Hz/min. or less (span \leq 2MHz, at a constant temperature after an hour of warming up)
Side band noise	: ≤ -105 dBc/Hz $f \leq 3.0$ GHz ≤ -101 dBc/Hz $f \leq 3.6$ GHz (20kHz offset)
Resolution	
3dB bandwidth	: 30Hz to 1MHz, switched 1 to 3 steps
6dB bandwidth	: 200Hz, 9kHz, 120kHz
Selectivity	: $\leq 15 : 1$ (60dB : 3dB)
Bandwidth accuracy	: $\pm 2\%$

R3261/3361
SPECTRUM ANALYSER
MAINTENANCE MANUAL

2.6 R3361B/D Specifications

Marker accuracy	
Normal mode	: Center frequency indication accuracy + span accuracy
Counter mode	: Indicated frequency x reference oscillator accuracy ± 1 count (Excepting TG mode)

(2) Amplitude Specifications

Amplitude measurement range	: -130dBm to +25dBm
Screen display range	
LOG mode	: 120dB (10dB/div) : 80dB (10dB/div) : 50dB (5dB/div) : 20dB (2dB/div) : 10dB (1dB/div)
LIN mode	: 10div
QP mode	: 80dB (10dB/div) Provided the measurement range is 70dB
Linearity display	
LOG mode	: ± 2.0 dB/110dB, ± 1.5 dB/70dB, ± 1.0 dB/10dB, ± 0.2 dB/1dB
LIN mode	: $\pm 5\%$ of the fullscale
QP mode	: ± 2.0 dB/70dB, ± 1.0 dB/40dB
Reference level indication range	: -109.9dBm to +40.0dBm 0.715 μ V to 22.4V
Reference level accuracy	: ± 0.3 dB 0 to -50dBm ± 0.7 dB +20 to -70dBm
Dynamic range	
Average noise level	: -121dBm + 1.55f(GHz)dB (Resolution bandwidth 300Hz, video bandwidth 1Hz, input attenuator 0dB, frequency 1MHz or more)
Secondary, tertiary distortion	: ≤ -70 dB -30dBm input (Input attenuator 0dB, frequency 10MHz or more)
Frequency response	: ± 0.5 dB (100kHz to 2GHz) ± 1.0 dB (9kHz to 3.6GHz) (LOG mode, input attenuator 10dB, 20 to 30°C)
Residual response	: ≤ -100 dBm (Input attenuator 0dB, 50 Ω terminator, frequency 500kHz or more)

R3261/3361
SPECTRUM ANALYZER
MAINTENANCE MANUAL

2.6 R3361B/D Specifications

- Resolution bandwidth switching accuracy
: $\pm 0.3\text{dB}$ (after automatic calibration)
- Video filter
: 1Hz to 1MHz (switched 1 to 10 steps)
- (3) Sweep Specifications
- Sweep time
: 30msec to 1000sec and Manual sweeping
- Sweep time accuracy
: $\leq 3\%$
- Trigger mode
: FREE RUN, LINE, VIDEO, EXT, TV-V, SINGLE
- (4) Input Specifications
- Input impedance
: Approx. 50Ω
: $\text{VSWR} \leq 1.5$ $100\text{kHz} \leq f \leq 2\text{GHz}$
: $\text{VSWR} \leq 2.0$ $9\text{kHz} \leq f \leq 3.6\text{GHz}$
: Input attenuator $\geq 10\text{dB}$ reference
- Input connector
: N connector
- Maximum input level
: +25dBm (input attenuator $\geq 30\text{dB}$)
: $\pm 50\text{VDC}$ max
- Input attenuator
: 0 to 50dB (10dB steps)
- Input attenuator switching accuracy
: $\pm 1.0\text{dB}$ ($\leq 2.0\text{GHz}$)
: $\pm 1.5\text{dB}$ ($\leq 3.6\text{GHz}$)
: Input attenuator 10dB standard
- Detection mode
: NORMAL, POSI, NEGA, SAMPLE
- (5) Tracking generator specifications
- Frequency range
: 9kHz to 3.6GHz
- Output level range
: 0dBm to -50dBm Setting can be done in
: steps of 1dB.
- Output level accuracy
: $\pm 0.5\text{dB}$ (30MHz, -10dBm, +20 to +30°C)
- Output level flatness
: $\pm 0.7\text{dB}$ (100kHz to 1.0GHz)
: $\pm 1.5\text{dB}$ (9kHz to 2.6GHz)
: $\pm 2.0\text{dB}$ (9kHz to 3.6GHz)
: (-10dBm output)

R3261/3361
SPECTRUM ANALYZER
MAINTENANCE MANUAL

2.6 R3361B/D Specifications

Output level switching accuracy	: $\pm 1.0\text{dB}$ (100kHz to 1.0GHz) $\pm 2.0\text{dB}$ (9kHz to 2.6GHz) $\pm 3.0\text{dB}$ (9kHz to 3.6GHz) (-10dBm reference)
Output spuriousness	: Harmonics spurious level $\leq -20\text{dB}$ Non-harmonics spurious level $\leq -30\text{dB}$ (Output level 0dBm)
TG leakage	: $\leq -110\text{dBm}$ (frequency $\leq 3.0\text{GHz}$) $\leq -100\text{dBm}$ (frequency $\leq 3.6\text{GHz}$)
Output impedance	: Approx. 50Ω
Output VSWR	: $\leq \pm 1.5$ (100kHz to 2.0GHz) $\leq \pm 2.0$ (9kHz to 3.6GHz) (At $\leq -10\text{dBm}$ output)
Output connector	: N-connector

(6) Output Specifications

External memory function:	IC memory card
Video output	: Approx. 1Vp-p, approx. 75Ω , composite
Sound monitor output	: The AM and FM sound can be monitored with an approximately 8Ω earphone.
Power supply for probes	: $\pm 15\text{V}$, 4-pin connector
Recorder output	: X axis approx. -5 to +5V, output impedance approx. $10\text{k}\Omega$ Y axis approx. 0 to +4V, output impedance approx. 220Ω
GPIB data output/ Remote control	: The built-in GPIB interface allows data output and remote control.
Direct plot	: Also, the built-in GPIB interface allows an output of on-screen data to the R9833 plotter to have a hardcopy.
Printer output	: The built-in GPIB interface allows HP2225AJ to output a hard copy of on-screen data.

R3261/3361
SPECTRUM ANALYZER
MAINTENANCE MANUAL

2.6 R3361B/D Specifications

(7) Indication Specifications

Indicated items : Waveforms, setting conditions, grid, label
CRT display unit : 5.5 inch
Trace : Two screens of A and B
WRITE : Signal response from the analyzer is indicated at every sweeping.
VIEW : The WRITE waveform contained in the memory, or other contents in the memory are displayed.
MAX HOLD : Indication of maximum signal level during repeated sweeping
AVG : Indication of average signal level during repeated sweeping

(8) Other functions (R3361D only)

Occupied bandwidth measurement/Adjacent channel leakage power measurement

Multi-marker function

(9) General Specifications

Using ambient conditions : 0 to 50°C
85%RH or less

Storage temperature range : -20 to +60°C

Power supply : The power voltage of the analyzer is set at the delivery according to the customer's ordering information.

Option No.	Standard	44
Line voltage (V)	90 to 132	198 to 250

48 to 66Hz

R3361D : Line voltage range 90 to 132VAC or 198 to 250VAC is automatically selected internally.
48 to 66Hz

R3261/3361
SPECTRUM ANALYZER
MAINTENANCE MANUAL

2.6 R3361B/D Specifications

Power consumption : 220VA or less
Dimensions : Approx. 330(W) x 177(H) x 450(D) mm
Mass : Approx. 17kg

(10) Options and Accessories

Option

OPTION 02 RS-232 interface
OPTION 04 Occupied bandwidth measurement/Adjacent channel leakage power measurement
OPTION 12 Gated sweep function
OPTION 15 Controller function
(Parallel I/O, Serial I/O)
OPTION 70 Multi-marker function
OPTION 72 Printer output
OPTION 80 RS-232 interface/Gated sweep function
OPTION 81 Controller function/Gated sweep function

Separate accessory

R3551 EMI preselector
R16211 Carrying case
A02804 Front cover
A09505 Memory card (32k byte, 5 pieces)
A09506 Memory card (128k byte, 5 pieces)
A02034 Panel Mount Kits
A02255 Rack Mount Kits (JIS)
A02455 Rack Mount Kits (EIA)

MEMO 

3. THEORY OF OPERATION

This section describes the R3261/3361 series of spectrum analyzers and their operation. This section describes the components of the R3261/3361 analyzers and their functions, and briefly explains how spectrum analyzers work.

3.1 How a Spectrum Analyzer Works

A spectrum analyzer is a device that graphically displays the energy distribution of the frequencies that make up a signal. The signal's spectrum is represented by a line whose vertical displacements show the amplitude of the signal at each frequency, as shown in Figure 3-1.

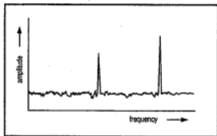

Figure 3-1 Typical Spectrum Analyzer Display

A spectrum analyzer uses circuitry similar to that in a superheterodyne radio receiver. The analyzer mixes the input signal with the signal from a swept local oscillator to produce an IF signal whose amplitude determines the vertical displacement of the line on the display. The local oscillator sweeps through a range of frequencies, thus changing the narrow frequency band being amplified at any time. The horizontal displacement of the displayed spectrum line is synchronized with the local oscillator frequency.

3.2 R3261/3361 Configurations

The R3261/3361 series of spectrum analyzers includes 8 models: R3261A/C, R3261B/D, R3361A/C, and R3361B/D. Table 3-1 summarizes the configurations of the 8 models, and shows the frequency bands that can be analyzed by each. The R3361 models also include a tracking generator (TG).

Table 3-1 R3261/3361 Configurations

Model	Frequency range		TG
	9kHz - 2.6GHz	9kHz - 3.6GHz	
R3261A/C	✓		
R3261B/D		✓	
R3361A/C	✓		✓
R3361B/D		✓	✓

3.3 How the R3261/3361 Works

Figure 3-2 (on the following page) shows a block diagram of the R3261/3361. The primary signal path through the R3261/3361 analyzer is as follows: The signal received by the analyzer (RF IN in the block diagram) passes through an input attenuator, and is mixed with a swept signal from the first local oscillator to produce the first IF signal (4.066 GHz). (The first local oscillator's frequency is controlled by a ramp signal from the CPU.) The first IF signal passes through three additional mixers to produce the fourth IF signal (3.58 MHz). This signal then passes through a logarithmic amplifier and an analog-to-digital converter, and is used by the CPU to control the vertical displacement of the spectrum line on the CRT.

The pages following Figure 3-2 describe in detail this process and the analyzer's components and their functions.

R3261/3361
SPECTRUM ANALYZER
MAINTENANCE MANUAL

3-3 How the R3261/3361 Works

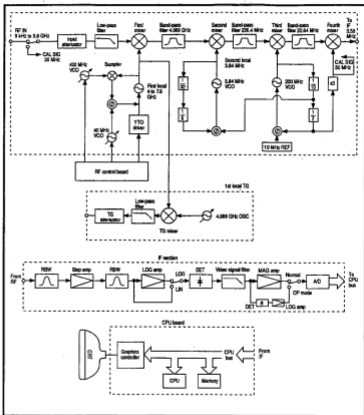

Figure 3-2 R3261/3361 Block Diagram

3.3.1 The Input Attenuator

Figure 3-3 below shows a circuit diagram of the R3261/3361 input attenuator.

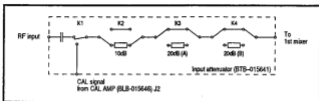

Figure 3-3 Input Attenuator

The input attenuator combines one 10 dB and two 20 dB attenuators to form an attenuator that can be set from 0 to 50 dB in 10 dB increments. The CPU controls the 10 dB and 20 dB attenuators according to the Input Attenuator setting. This setting has two operating modes: an automatic mode that sets the attenuator according to the reference level, and a manual mode that sets the attenuator according to front panel switch settings. Table 3-2 shows these switch settings.

Table 3-2 Attenuator Switch Settings

Attenuator Setting	10 dB K 2	20 dB (A) K 3	20 dB (B) K 4
0 dB			
10 dB	on		
20 dB		on	
30 dB	on	on	
40 dB		on	on
50 dB	on	on	on

on = switch set to the attenuator position.

Unlike conventional spectrum analyzers, the R3261/3361 does not use an external calibration signal. Instead, the R3261/3361 has a self-calibration function that uses an internal calibration signal (see Section 4.1.2). The K1 switch selects this internal signal.

3.3.2 First Mixer/Coupler

Figure 3-4 shows the first mixer/coupler.

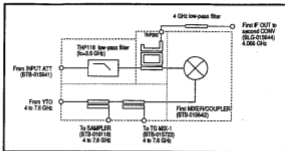

Figure 3-4 First Mixer/Coupler

The first local oscillator signal generated by the YTO (4 to 6.4GHz for the R3261A,C/3361A,C, 4 to 7.6GHz for the R3261B,D/3361B,D) is distributed to the sampler and the TG MIX-1 circuitry before passing to the first mixer/coupler. The input signal from the INPUT ATT terminal passes through the low-pass filter to the mixer/coupler, where it is combined with the first local oscillator signal mix to generate the first IF signal (4.066 GHz). The IF signal then passes through a 4 GHz low-pass filter to the second CONV board (BLG-015644).

Once the SMA connector is active with the YTO output signal, it is possible to check the level and frequency of the first local by removing the SMA connector (frequency range: 4 GHz - 7.6 GHz, level at 4 GHz: 8 dBm).

3.3.3 Second Mixer/Second Local

Figure 3-5 shows the second mixer/second local oscillator.

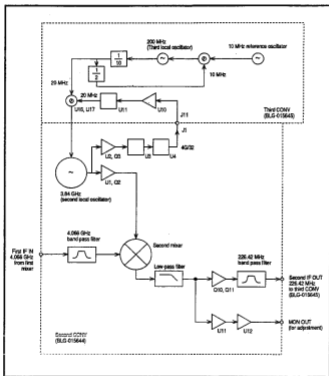

Figure 3-5 Second Mixer/Second Local Oscillator

The first IF signal (4.066 GHz) passes through a 4.066 GHz band-pass filter to the second mixer, where it combines with the second local oscillator signal (3.84 GHz) to create the second IF signal (226.42 MHz). (Note that this intermediate frequency is the difference between 4.066 GHz and 3.84 GHz.) The second IF signal is then amplified by Q10 and Q11 and sent through a 226.42 MHz band-pass filter to the third converter.

The second local oscillator is phase-locked to the internal reference oscillator through the phase-locked loop (P.L.L.) circuit of the third CONV. The monitor out (MON OUT) signal is used to measure the second IF signal and the second local oscillator signal.

Since the second local output is unavailable directly, check for oscillation by monitoring the local leakage signals at the second mixer output (frequency: 3.84 GHz, level: -39 dBm).

Figure 3-6 shows the spectrum distribution of the signal at the MON OUT terminal.

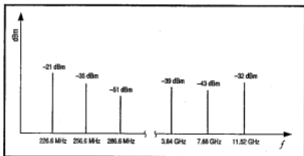

Figure 3-6 Spectrum Distribution at the MON OUT Terminal

3.3.4 Third and Fourth Mixers and Local Oscillators

Figure 3-7 shows the third and fourth mixers and local oscillators.

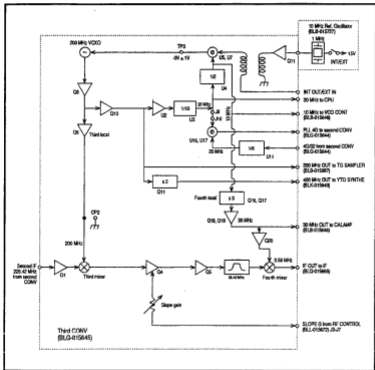

Figure 3-7 Third and Fourth Mixers and Local Oscillators

Third local oscillator

The third local oscillator is a 200 MHz crystal oscillator that is phase-locked to either the built-in reference oscillator or the external reference input. (The phase lock voltage for the 200 MHz signal is $-3 \text{ VDC} \pm 1 \text{ VDC}$ at TP3.) The 200 MHz signal from this oscillator is used as the reference signal for generating the frequencies used by the local oscillators at all other mixer stages.

The frequency multiplier (Q11 and other components not shown in Figure 3-7) multiplies the 200 MHz signal by two and supplies the resulting signal to the YTO SYNTH board (BLK-015649).

Check the level of the third local oscillator signal by using the TG sampler signal at the third CONV P5 or the UM cable exit on the TG side (frequency: 200 MHz, level: -5 dBm).

Third mixer

The third mixer combines the second IF signal (226.42 MHz) and the third local oscillator signal (200 MHz) to generate the third IF signal (26.42 MHz).

Third IF/filter

The third mixer output signal (third IF signal) passes through the low-pass filter, through a slope gain amplifier (Q4), and through a total gain amplifier (Q5). The amplified signal then passes through the third IF band-pass filter to the fourth mixer.

Fourth local oscillator

The fourth local oscillator signal (30 MHz) is generated by dividing the third local oscillator frequency (200 MHz) by 20 and multiplying the resulting signal by three. The fourth local oscillator signal is also used as the CAL signal.

Check the fourth local oscillator signal by using the CAL AMPLIFIER signal at the third CONV J6 (frequency: 30 MHz, level: 4 dBm).

Fourth mixer

The fourth mixer combines the third IF signal (26.42 MHz) and the fourth local oscillator signal (30 MHz) to produce the fourth IF signal (3.58 MHz) at IF OUT.

Second local oscillator P.L.L.

The second CONV supplies the second local oscillator signal (3.84 GHz) divided by 32. U11 further divides the signal by 6 to produce a 20 MHz signal. The digital phase detector (U16 and U17) compares the 20 MHz signal with the output of the divider, U3. U16 and U17 provide the proper signal by dividing the third local oscillator signal by 10. The second local oscillator is now locked in phase.

Reference oscillator

The 10 MHz reference frequency for the local oscillators is either an internal crystal-controlled oscillator or an external oscillator signal supplied to the INT/EXT connector. The oscillator used is selected by the INT/EXT switch on the rear panel.

3.3.5 IF Step Amplifiers

Figure 3-8 shows the IF step amplifiers.

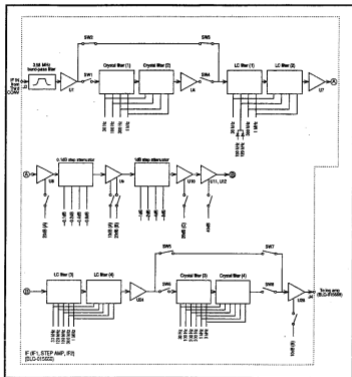

Figure 3-8 IF1 and IF2 Step Amplifiers

The step amplifier consists of two fixed attenuators (0.1 dB step and 1 dB step) and six fixed-gain amplifiers: two 10 dB amplifiers (U28 and U9), three 20 dB amplifiers (U8, U9, and U10), and one 40 dB amplifier (U11). The attenuation is controlled by the INPUT ATT and REF LEVEL settings. Both attenuators are set automatically by the CAL data, which includes data for MAG accuracy, RBW switching accuracy, and frequency characteristics correction.

The latch IC (U42) supplies the RBW select signal to the IF filters. Table 3-3 shows the RBW setup signal for each U42 output pin, and summarizes the RBW setup, the corresponding filters, and the LC/X'tal switch setup (U42 output).

Table 3-3 RBW Setup

		U42 Pin No.												
RBW Setup		6	5	4	64	61	60	59	55	54	3	56	7	8
L/C	1 MHz	●											●	●
	300 KHz		●										●	●
	100 KHz			●									●	●
	30 KHz				●								●	●
	10 KHz												●	●
X'tal	3 KHz					●								
	1 KHz						●							
	300 Hz							●						
	100 Hz								●					
	30 Hz									●				
QP	120 KHz										●		●	●
	9 KHz													●
	200 Hz										●			

- 1) ● = 0V, blank = 5V
- 2) Pin 7: 0V SW2 = SW3 = on, SW1 = SW4 = off
- 3) Pin 8: 0V SW5 = SW7 = on, SW6 = SW8 = off

Table 3-4 shows the relationship between the REF LEVEL and the step amplifier settings.

Table 3-4 REF LEVELs and Step Amplifier Settings

REF LEVEL	10 dB (A)	10 dB (B)	20 dB (A)	20 dB (B)	20 dB (C)	40 dB
0 dBm						
-10 dBm	✓					
-20 dBm			✓			
-30 dBm	✓		✓			
-40 dBm			✓	✓		
-50 dBm	✓		✓		✓	
-60 dBm			✓	✓	✓	
-70 dBm	✓		✓			✓
-80 dBm			✓	✓		✓
-90 dBm		✓	✓	✓		✓

- 1) ✓ = on, blank = off
- 2) This table shows the setup condition with the dynamic range set to 80 dB and the INPUT ATT set to 10 dB.

3.3.6 LOG/QP

Figure 3-9 shows the LOG/QP circuitry.

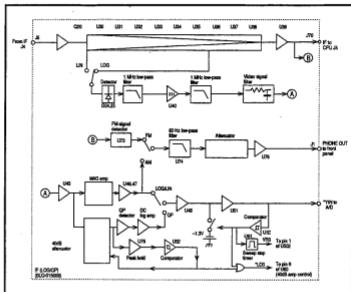

Figure 3-9 LOG/QP

LOG amplifier

The LOG amplifier uses nine stages of serial hybrid ICs to provide 80 dB of dynamic range. The signal is rectified and passed through the low-pass and video filters before being passed to the PAR amplifier (which is a switchable gain amplifier). In the linear (LIN) mode, the signal goes directly to the detector without going through the logarithmic (LOG) amplifier. The video filter can be switched in seven stages between 1 Hz and 1 MHz.

MAG amplifier, PHONE OUT, and 120dB display

The MAG amplifier forms the 1/2, 1/5 and 1/10 attenuators that divide the LOG amplifier output to generate the 5 dB/div, 2 dB/div, and 1 dB/div signals. In the 0.5 dB/div, 0.2 dB/div, and 0.1 dB/div modes, the IF signal bypasses the LOG amplifier and instead passes through the LIN amplifier.

The R3261/3361 provides AM and FM audio output to the front panel PHONE terminal. The FM decoding mode uses the FM detector. AM and FM modes pass signals through the low-pass filter and attenuator to provide voice level control.

The comparator (U52) detects the ON/OFF level of the 40 dB amplifier during a 120 dB dynamic range display (see Section 3.3 and Figure 3-2), and the sweep stop timer (U61) stops sweeping during ON/OFF switching of the 40 dB amplifier.

QP (for 70dB display)

The R3261/3361 has a QP (quasi-peak) measuring section that consists of a QP detector and a DC LOG amplifier. To increase the dynamic range of the QP detector, the signal is attenuated by the 40 dB attenuator before passing through the QP detector, and amplified by the DC LOG amplifier after passing through the QP detector.

3.3.7 Analog-to-digital Conversion and Ramp Generator

Figure 3-10 (on the following page) shows the analog to digital (A/D) conversion and ramp generator circuitry.

Ramp generator

U503 and U504 form the CPU-programmable ramp generator. When the CPU sends data to determine the sweep time, U503 automatically sends the corresponding digital data to U504. Since U504 receives continuous digital data, the result is a ramp waveform output.

A/D conversion

The LOG amplifier output (*Y IN) passes through the POSI/NEGA (positive/negative) peak hold circuit and then the A/D converter U535. The comparators U527 and U528 form the slope detect circuit. (The slope is used to trigger the Peak Hold circuit.)

Trigger signal detection

U538-1, U538-2, U539-2, and U546-1 generate the VIDEO trigger signal. An integrator circuit formed by an electronic switch, a capacitor, and U539-1 detects the vertical sync signal in the TV signal. Once detected, this signal is used as the TV-V trigger; the power unit provides the LINE trigger.

R3261/3361
SPECTRUM ANALYZER
MAINTENANCE MANUAL

3.3 How the R3261/3361 Works

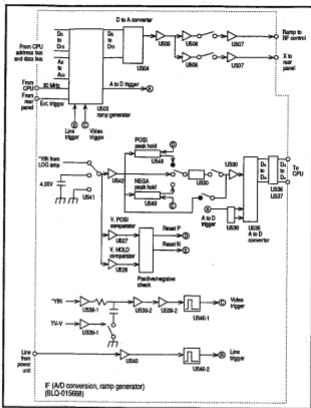

Figure 3-10 A/D Conversion and Ramp Generator

3.3.8 First Local Oscillator

Figure 3-11 shows the first local oscillator. The oscillator has four different operations, controlled by the SPAN front-panel setting.

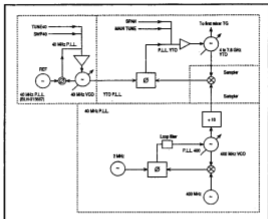

Figure 3-11 First Local Oscillator

Table 3-5 shows the SPAN settings for each of the four oscillator operations.

Table 3-5 SPAN Setting and P.L.L. Functions

SPAN	YTO P.L.L.	400 MHz P.L.L.	40 MHz P.L.L.	Sampler
3.6 GHz - 500 MHz	free run	not used	not used	off
499 MHz - 2.01 MHz	free run/locked	locked	locked	on: sweep end only
2 MHz - 1 KHz	locked	locked	free run/locked	on
0 Hz	locked	locked	locked	on

- 1) free run: local oscillator sweeps.
- 2) free run/locked: once locked on the sweep end the voltage is held by the sample hold circuit. The voltage is then applied to the local oscillator on the next sweep to improve the accuracy of the center frequency.

400MHz P.L.L.

Figure 3-12 (on the following page) shows the circuit diagram for the 400 MHz P.L.L., one of the major components of the first local oscillator. The 400 MHz P.L.L. has the following characteristics:

- The 400 MHz VCO is locked in phase with the reference oscillator.
- U10 is a divider for 1/8 and 1/9 (see Figure 3-12).
- U11 contains two programmable dividers.
- U10 and U11 (1/2) combine to form a swallow counter that constitutes the 1/N divider.
- U11 (2/2) is the 1/M divider.
- If the YTO lock is OFF, the loop filter turns Q1 OFF by changing Q1's bias to prevent the sampler from receiving signals.
- The division ratio is set by the M and N data provided by the CPU (at U11).
- The CPU can switch the loop filter to four-way operations, depending on the N value (see Table 3-6). This gives the first local oscillator better phase noise characteristics in different operating modes.

Table 3-6 400MHz VCO Loop Filter Settings

Switch	SPAN setting			
	N ≤ 89		N ≤ 139	N ≤ 261
	M ≤ 27	M ≥ 28		
NAR400N	off	on	off	off
NAR400W	on	off	on	off

- 1) M: integer degree variable (19-37)
- 2) N: integer division variable (62-261)

YTO P.L.L.

Figure 3-13 shows the YTO P.L.L.

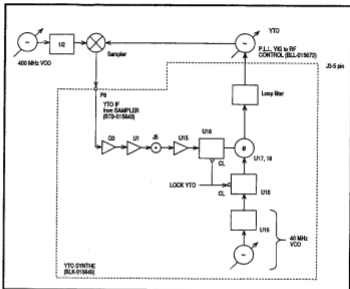

Figure 3-13 YTO P.L.L.

In some sweep modes the first local oscillator is locked only at the end of the sweep. To avoid drift, the YTO IF signal and the 40 MHz VCO signal lock the YTO P.L.L. in phase. If drift cancel is active (lock is OFF), the YTO lock is used as the sample hold circuit.

The YTO P.L.L. loop filter is adjusted by the SPAN setting, which is set at NAR YTO. Table 3-7 shows the filter settings.

Table 3-7 YTO P.L.L. Loop Filter Settings

Switch	SPAN setting	
	≥ 10 KHz	≤ 9.9 KHz
NAR YTO	ON	OFF

When the SPAN setting is 400 MHz VCO and YTO is in free run (see Table 3-5), U16 is made CLEAR to break the lock loop.

40MHz P.L.L.

The 40 MHz VCO generates signals at 380 MHz. The signals are then divided by U25 and the resulting signal is passed to the YTO P.L.L.

The VCO CONT (BLC-015650) U1 is a sample hold circuit used to cancel drift when the 40 MHz P.L.L. is free-running. The P.L.L. voltage (P.L.L. 40), the TUNE voltage (TUNE 40), and the sweep voltage (SWP40) are all summed and linearized in U3. The signals are then passed to the 380 MHz VCO.

3.3.9 RF Control

Figure 3-14 (on the following page) shows the RF control circuitry. This circuitry converts the signals from the ramp generator to sweep signals for the YTO main, the YTO FM, and the 40 MHz VCO (see Figure 3-13). The D/A converter (U8) attenuates the ramp signals to an adjustable reference voltage. Because of its operation U8 is regarded as a programmable attenuator.

D/A converters U12 and U11 generate the 40 MHz VCO TUNE voltage, and D/A converter U10 controls the CAL signal level. The LOG SPAN (a sweep mode that displays output on an analog scale) uses the LIN-LOG circuit Q1. LOG SPAN is set from the front panel.

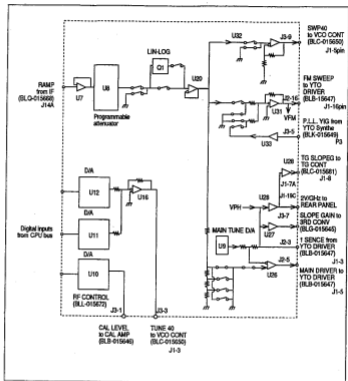

Figure 3-14 RF Control

3.3.10 YTO Driver

Figure 3-15 shows the YTO and YTO driver circuitry. This circuitry converts the YTO driving voltage to current for use by the MAIN and FM circuitry (see YTO P.L.L. in Section 3.3.8). When the SPAN setting is 10 MHz or less, capacitor $C7$ and the MAIN coil operate as a noise filter. When the filter is OFF the capacitor charges and discharges through $U2$ to prevent frequency drift.

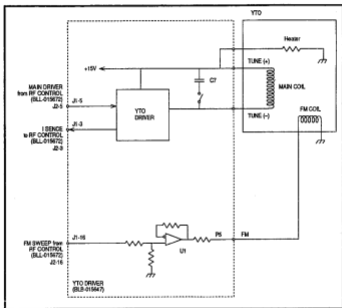

Figure 3-15 YTO Driver

3.3.11 CAL Amplifier

Figure 3-16 shows the CAL amplifier. The 30 MHz signal generated by the fourth local oscillator passes to the INPUT ATT (CAL SIGNAL). The CAL amplifier accurately changes the gain of the saturation amplifier: for example, at a CAL LEVEL of -9.6V to -3.0V the CAL SIGNAL becomes -20.0 dBm to -30.0 dBm.

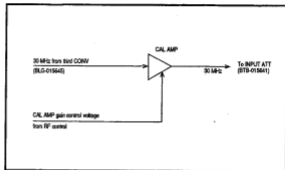

Figure 3-16 CAL Amplifier

Table 3-8 shows the relationship between the CAL LEVEL and the CAL SIGNAL.

Table 3-8 CAL LEVELs and CAL SIGNALs

CAL LEVEL (V)	CAL SIGNAL (dBm)
-9.6	-20.0
-8.9	-20.5
-8.4	-21.0
-8.0	-21.5
:	:
-3.5	-28.5
-3.4	-29.0
-3.2	-29.5
-3.0	-30.0

3.3.12 Tracking Generator (R3361A,C/B,D Only)

Figure 3-17 shows the circuitry for the tracking generator (TG). The TG contains the TG Mixer and an output amplifier to allow direct viewing of frequency attenuations of 115 dB or more.

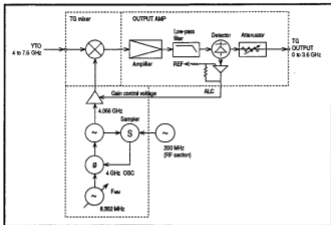

Figure 3-17 Tracking Generator Block Diagram

Unlike conventional tracking generators that generate tracking output signals by inversely mixing each local signal, the R3361A,C/B,D produces the TG output by mixing the second IF (4.066 GHz) and YTO signals.

Output amplifier

The output amplifier shown in Figure 3-18 (on the following page) amplifies the TG mixer signals with a total gain ≥ 30 dB and applies the ALC (Automatic Level Control) voltage to the amplifier to provide a consistent output level for all frequencies.

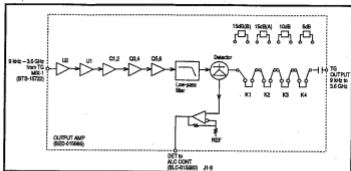

Figure 3-18 Output Amplifier

The TG output level can be adjusted in 5 dB steps by varying the ALC voltage in steps of 1 dB. Table 3-9 shows the relationship between ALC voltage and TG output level.

Table 3-9 Switch Settings for TG Output Levels

Output level (dBm)	5 dB K 4	10 dB K 3	15 dB (A) K 2	15 dB (B) K 1
0				
-5	✓			
-10		✓		
-15	✓	✓		
-20	✓			✓
-25		✓		✓
-30	✓	✓		✓
-35	✓		✓	✓
-40		✓	✓	✓
-45	✓	✓	✓	✓
-50	✓	✓	✓	✓
OFF	✓	✓	✓	✓

✓ = Attenuator ON (relay driving voltage = -12V)

Tracking generator mixer

Figure 3-19 shows the TG mixer. This circuitry mixes the output from its 4 GHz oscillator with the signals from the first local oscillator. Note that the mixer follows the sweep frequency while generating its output signals (9 KHz to 3.6 GHz).

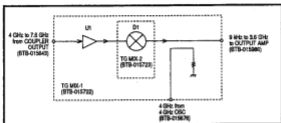

Figure 3-19 TG Mixer

4GHz oscillator

Figure 3-20 (on the following page) shows the 4 GHz oscillator (OSC). Input signals are sampled at 200 MHz (third local oscillator) and phase-locked to the reference oscillator (8.302 MHz VCXO, 7 V).

Tracking errors resulting from errors between the first local oscillator and the TG output can be compensated by adjusting the frequency of the reference oscillator. This adjustment also prevents errors caused by the resonic oscillator, TG P.L.L., or TG SAMPLER U1 power supplies. Adjusting the oscillator's frequency sets the TG attenuator to 45 dB.

Tracking generator control

The tracking generator control (TG CONT) consists of a latching IC (U1) and a D/A converter (U2). The latch IC feeds preset signals for the attenuator, the TG ON/OFF state, and the ALC band to the proper circuitry block. The D/A converter is used to fine tune the oscillation frequency of the reference oscillator. See Figure 3-20.

ALC (Automatic Level Control)

The ALC circuitry combines the SLOPE voltage and the DET voltage, then applies the sum to the ALC modulator. The TG output level and the frequency response can be kept constant by varying the output level of the ALC modulator. See Figure 3-20.

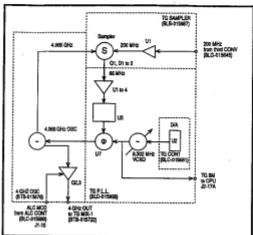

Figure 3-20 4GHz Oscillator

Compensation for tracking error (R3361 only)

The R3361 features three tracking error compensation modes: FREC CAL AUTO mode, FREC CAL MANUAL mode, and TG TRACKING mode. These modes are described below.

FREC CAL AUTO mode

In this mode the R3361 measures the frequencies of the fourth IF (3.58 MHz) and the reference oscillator (8.302 MHz VCXO) for the TG 4 GHz OSC. The tracking error of the RBW setting is calculated from the SYNTHSE setting.

The error compensation value is sent to the D/A converter of TG controller U2, then to the reference oscillator. If the RBW is 3 KHz or higher, a compensation value of 1 KHz is used.

FREC CAL MANUAL mode

When in this mode the R3361 uses a compensation value from 000H to FFFH. This value can be manually set in the error compensation D/A converter.

TG TRACKING mode

In this mode the tracking error compensation is made in four RBW bands: 1 KHz, 300 Hz, 100 Hz and 30 Hz. If the RBW is 3 KHz or higher, a compensation value of 1 KHz is used.

3.3.13 Central Processing Unit and Peripherals

Figure 3-21 shows the R3261/R3361 mother board.

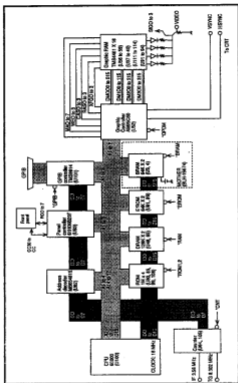

Figure 3-21 R3261/3361 Mother Board

The R3261/3361 mother board contains a Motorola 68000 16-bit CPU and several peripheral chips:

- E²ROM (U81, 86) contains the frequency characteristic compensation data for the RF circuitry.
- SRAM (MOTHER U3, 4) contains the CAL data and the SAVE/RECALL setting.
- Gate Array (U82) (made by ADVANTEST) is an address decoder.
- Panel Controller (U93) is a controller for the keypad.
- GPIB controller (U101) is the interface controller.
- Graphic Controller (U52) is the CRT display controller.

Memory map

Table 3-10 shows the CPU memory map of the R3261/3361. The table shows how the CPU memory is allocated, and the READ/WRITE abilities of particular memory devices.

Table 3-10 Memory Map

Signal	Address	READ	WRITE	Remarks
ROM	000000 - 0FFFFF	✓		Program ROM
RAM	100000 - 13FFFF	✓	✓	RAM
GRAM	140000 - 17FFFF	✓	✓	RAM in optional controller board
BRAM	180000 - 1B3FFF	✓	✓	SAVE/RECALL RAM (on mother board)
RAMP	184000	✓	✓	Ramp generator (IF BLQ-015668 U503)
A/D	188000	✓	✓	A/D converter
I/O	18C000	✓	✓	Optional controller board
MCARD	190000	✓	✓	Memory card
HSAD	194000		✓	Optional high speed A/D converter
ARAM	198000 - 19FFFF	✓	✓	Memory in high speed A/D converter
EROM	1A0000 - 1A3FFF	✓	✓	E ² ROM (frequency characteristics compensation data)
KEY	1A4000	✓	✓	Panel controller (61H06B23F)
QFDM	1A8000	✓	✓	Graphic controller (Am95C60)
GPIB	1AC000	✓	✓	GPIB controller (TMS9914)
CNT	1B0000	✓	✓	Counter
PDINT	1B4000	✓		Interrupt (level 3) detail check
SELCl	1B8000		✓	Selection of counter input signal (IF, TG)

(Cont'd)

Signal	Address	READ	WRITE	Remarks
CSTART	1B8100		✓	Counter start
CICLR	1B8200		✓	Counter interrupt clear
GRST	1B8300		✓	Graphic controller reset
CLRSTD	1B8400		✓	STD interrupt clear
MICLR	1B8500		✓	Marker interrupt clear
CLRSTP	1B8600		✓	Sweep stop clear
DISP	1B8700		✓	Display control
CSRF	1C0000		✓	RF block
CSLOG	1D0000		✓	LOG part
CSIF	1E0000		✓	IF part

Debug Mode

The R3261/3361 has a built-in debug mode that allows data to be read from or written to any memory address. Debug mode offers six functions that can be selected by pushing the soft keys. These functions are as follows:

- **READ/WRITE** – reads a specified memory address immediately after writing to it. This function is used as a WRITE/READ test for the RAM.
- **READ ONLY** – continuously reads a specified memory location. READ ONLY is used to monitor the CAL correction and A/D converter data. The R3261/3361 continues to display waveform data while executing READ ONLY.
- **WRITE ONLY** – continuously writes data to a specified address location. WRITE ONLY is used to configure the operation of the analyzer.
- **READ LOOP** – limits memory reads to a specified address (the address can be determined by using the READ ONLY function). Since the R3261/3361 does not display waveforms in a READ LOOP, this function is used mainly for monitoring logic signals.
- **WRITE LOOP** – limits memory writes to a specified address.
- **RETURN** – exits debug mode.

To access debug mode, turn ON the spectrum analyzer, then press **[SHIFT]** and **[BK SP]** on the keyboard. Figure 3-22 shows the display that appears.

4. PERFORMANCE TEST

4.1 General

4.1.1 Testing Equipment

Equipment to be used for the performance test is listed in Table 4-1. The cables needed are listed in Table 4-2.

Table 4-1 Test Equipment

Test Equipment	Required Performance	Recommended Equipment
Synthesized Signal Generator	Frequency : to 3.6 GHz Output Level : +10 dBm to -30 dBm Output Impedance : 50Ω AM Modulation : 100 Hz with 30% Modulation (or external modulation)	Advantest R4262
Low Distortion Signal Generation (or synthesized signal generator with low pass filter)	Frequency : to 1.8 GHz Output Level : -10 dBm Output Impedance : 50Ω Second Harmonic Frequency : 60dB or less for -10dBm output	Advantest R4262 +L.P.F.
RF Power Meter	Frequency : to 3.6 GHz Sensitivity : +20 dBm to -50 dBm : ±0.2 dB	Generic
Attenuator	Frequency : to 500 MHz Attenuation : 10 dB step : 0 to 110 dB : 1 dB step : 0 to 11 dB Stability : 10dB : ±0.2 dB : 1dB : ±0.02 dB	Generic
Low-Frequency Generator	Frequency : 100 Hz Output Level : 1 Vp-p	Generic
Frequency Comparator		Generic
Frequency Standard	Stability : 2×10^{-9}	Advantest TR3110

Table 4-2 Cables & Adapters Required

Product Name	Model	Stock No.	Remarks
Connecting Cable (BNC-BNC)	MI-02	DCB-PP0386	
Connecting Cable (SMA-SMA)	A01002		
N-BNC Conversion Adapter	JUG-201A/U	JCF-AP001Ex03	
N-SMA Conversion Adapter			

4.1.2 Calibration

Self-calibration is an important factor for the high performance spectrum analyzer. Let the system warm up for 30 minutes and then start the self-calibration performance test. Self-calibration is started by the following keystrokes.

SHIFT 7 CAL ALL

(SOFT KEY 1)

The calibration should be made on the following items:

- (1) INPUT ATTENUATOR
- (2) IF STEP AMP
- (3) RBW SWITCHING
- (4) LOG LINEARITY
- (5) AMPLITUDE MAG
- (6) TG TRACKING

4.2 Testing CAL Signals

The CAL signal frequency accuracy is same as that of the reference oscillator because the CAL signal is phase-locked to the reference oscillator.

$\pm 2 \times 10^{-6}/\text{day}$
 $\pm 1 \times 10^{-7}/\text{year}$

Procedure

- 1 Preset and then set spectrum analyzer to the following settings.

CENTER FREQ	:	30MHz
FREQ SPAN	:	2MHz
RBW	:	30kHz
dB/div	:	1dB
REF LEVEL	:	-15dBm

- 2 Enter a 30MHz, -20.0dBm signal from an external signal generator to the system.
- 3 Adjust the REF LEVEL so that the spectrum of the signal appears at the center of the screen.
- 4 Remove the cable that is connected to the external signal generator. Make the CAL SIG (at -20.0dBm) appear on the screen.

SHIFT	7	CAL SIG ON/OFF
-------	---	-------------------

(SOFT KEY 4)

- ⑤ Check that the difference is within $\pm 0.3\text{dB}$ between the levels of the signal at the input from SG and the CAL SIG. If not, make adjustments according to the chapter 5. "ADJUSTMENTS" in maintenance manual.

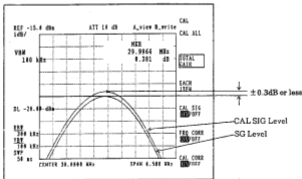
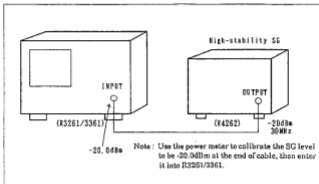

4.3 Test Using Internal Signal

4.3.1 Testing Noise Sideband

Procedure

- ① From the preset condition, set the spectrum analyzer as follows:

CENTER FREQ : 0MHz
FREQ SPAN : 40kHz
ATT : 0dB
VBW : 10Hz
RBW : 300Hz

- ② Read the peak level of the zero spectrum using the marker.
- ③ Set the spectrum analyzer as follows:
- REFLEVEL : -50dBm
- ④ Read the average left end level of the noise waveform as it appears on the screen.
- ⑤ Obtain the noise sideband (with 20kHz offset) from the levels determined in steps ② and ④ above.

The formula used is:

result of ② put into XdB

result of ④ put into YdB

$$|Y - X| - 23\text{dBc/Hz} \leq -105\text{dBc/Hz}$$

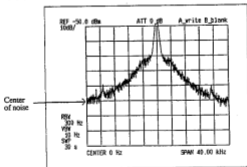

4.3.2 Testing Frequency Drift

Procedure

- 1 Preset and then set the spectrum analyzer to the following settings:

CENTER FREQ : 0MHz
FREQ SPAN : 1kHz

- 2 Confirm that the drift of the zero spectrum as measured for one minute is within 300Hz.

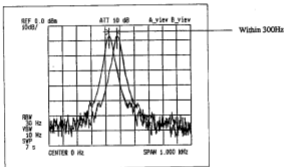

4.3.3 Testing Resolution Bandwidth (3dB bandwidth)

Procedure

- ① Preset and then set the spectrum analyzer to the following settings:

CENTER FREQ : 30MHz
FREQ SPAN : 2MHz
RBW : 1MHz
REF LEVEL : -18dBm
dB/div : 1dB
CAL SW : ON

- ② Set the spectrum analyzer as follows:

PEAK
ΔMKR

- ③ By turning the data knob counterclockwise, move the marker to such a position as to give a 3dB difference between the two points indicated by the marker.

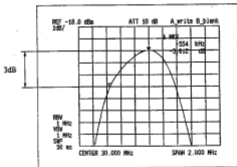

- ④ Set the spectrum analyzer as follows:

ΔMKR

- ⑤ By turning the data knob counterclockwise, move the marker to such a position as to give a 0.0dB difference between the two points indicated by the marker.

Cont'd

4.3 Test Using Internal Signal

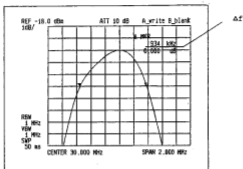

- ⑥ Confirm that the frequency difference, Δf , is within $\pm 20\%$ of the set value.
- ⑦ Check for 300kHz and 3kHz resolution bandwidths by performing steps ② through ⑥ above. Table 4-3 lists the span values most suitable to each resolution bandwidth. If the test result falls out of the specification, make adjustments in accordance with "5.4.3 Resolution Band Width Switching Between".

Table 4-3 Relationship Between Resolution Bandwidth and Span

RBW [Hz]	1M	300k	3k
FREQ SPAN [Hz]	2M	500k	5k

4.3.4 Testing Selectivity of Resolution Bandwidth

Procedure

- ① From the preset condition, set the spectrum analyzer as follows:

CENTER FREQ : 30MHz
FREQ SPAN : 5MHz
RBW : 1MHz
VBW : 10kHz
ATT : 0dB
REF LEVEL : -20dBm
CAL SIG : ON

- ② Set the spectrum analyzer as follows:

PEAK
ΔMKR

- ③ By turning the data knob counterclockwise, move the marker to such a position as to give a 60dB difference between the two points indicated by the marker.

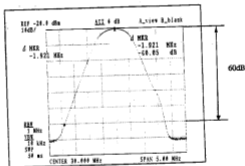

- ④ Set the spectrum analyzer as follows:

ΔMKR

Cont'd

- ④ By turning the data knob counterclockwise, move the marker to such a position as to give a 0.0dB difference between the two points indicated by the marker.

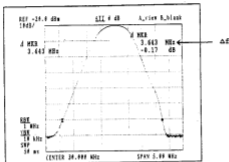

- ⑤ The 60dB bandwidth of the IF filter is given as the frequency difference, Δf , between the two points. Confirm that the ratio of this value to the value obtained in the resolution bandwidth test is 15:1 or less.
- ⑥ Check for 300kHz and 3kHz resolution bandwidths by performing steps ② through ④ above. Table 4-4 shows the relationship between resolution bandwidth and FREQ SPAN. If the test result falls out of the specification, make adjustments according to "5.4.3 Resolution Band Width Switching Between".

Table 4-4 Settings for Resolution Bandwidth Selectivity Test

RBW [Hz]	1M	300k	3k
FREQ SPAN [Hz]	5M	5M	50k
VBW [Hz]	10k	10k	1k

4.3.5 Testing Stability of QP Bandwidth

The QP value measurement is for measuring the pulse characteristic noise. Various constants in this measurement are defined values in the CISPR Standards as shown in Table 4-5.

Table 4-5 CISPR Standards for QP Value Measurement Basic Characteristic

Measuring band	6dB bandwidth	Charging time constant	Discharging time constant	Mechanical time constant
10kHz to 150kHz	200Hz	45ms	500ms	160ms
150kHz to 30MHz	9kHz	1ms	160ms	160ms
30MHz to 1GHz	120kHz	1ms	550ms	100ms

Procedure

- ① From the preset condition, set the spectrum analyzer as follows:

CENTER FREQ : 30MHz
FREQ SPAN : 200kHz
REF LEVEL : -18dBm
dB/div : 2dB/
QP BW : 120kHz (6dB)
CAL SIG : ON

- ② Set the spectrum analyzer as follows:

PEAK
AMKR

- ③ By turning the data knob counterclockwise, move the marker to such a position as to give a 6dB difference between the two points indicated by the marker.

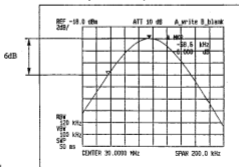

Cont'd

- ④ Set the spectrum analyzer as follows:

Δ MCR

- ⑤ By turning the data knob counterclockwise, move the marker to such a position as to give a 0.0dB difference between the two points indicated by the marker.

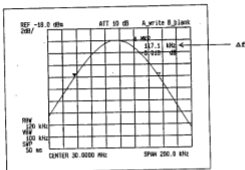

- ⑥ Confirm that the frequency difference, Δf , between the points is within 110kHz to 130kHz.
- ⑦ Check for 9kHz and 200Hz QP bandwidths by performing steps ② to ⑥ above. Table 4-6 shows the relationships between QP bandwidth, FREQ SPAN and sweep time.

Table 4-6 Setting for the QP Bandwidth Stability Test

QP bandwidth	120kHz	9kHz	200Hz
FREQ SPAN	200kHz	20kHz	2kHz
Sweep time	50ms	100ms	2sec

4.3.6 Testing Stability of Marker Indication (In normal mode)

Procedure

- ① From the preset condition, set the spectrum analyzer as follows:

CENTER FREQ : 30MHz
FREQ SPAN : 20MHz
CAL SIG : ON
MARKER : PEAK

- ② Confirm that the marker indication is within 30MHz \pm 1.05MHz.

- ③ Set the spectrum analyzer as follows:

FREQ SPAN : 10MHz
MARKER : PEAK

- ④ Confirm that the marker indication is within 30MHz \pm 0.55MHz

- ⑤ Set the spectrum analyzer as follows:

FREQ SPAN : 2MHz
MARKER : PEAK

- ⑥ Confirm that the marker indicator is within 30MHz \pm 0.16MHz.

4.3.7 Testing Stability of Marker Indication (In counter mode)

Procedure

- ① From the preset condition, set the spectrum analyzer as follows:

CENTER FREQ	:	30MHz
FREQ SPAN	:	1kHz
CAL SIG	:	ON
MARKER	:	PEAK
	:	COUNTER
RESOLUTION	:	1Hz

- ② Confirm that the marker indication is within $30\text{MHz} \pm 1\text{Hz}$.

4.3.8 Testing Average Noise Level

Procedure

- ① From the preset condition, set the spectrum analyzer as follows:

ATT : 0dB
REFLEVEL : -70dBm
RBW : 1MHz
VBW : 1kHz
START FREQ : 50MHz
STOP FREQ : 3600MHz (2600MHz for R3261A,C/R3361A,C)

- ② At completion of the sweep, set the spectrum analyzer as follows:

Press the **PEAK**, **MKR→** and **MKR→** keys.
:MKR→:
:CF : keys.
:.....:

SPAN : 1kHz
RBW : 300Hz
VBW : 1kHz

- ③ Confirm that the noise level at the frequency, in GHz, determined in step ② above is -121dBm + 1.55f [GHz] or less.

4.3.9 Testing Residual Response

Procedure

- ① From the preset condition, set the spectrum analyzer as follows:

CENTER FREQ	:	250MHz
SPAN	:	500MHz
RBW	:	30kHz
VBW	:	1kHz
ATT	:	0dB
REF LEVEL	:	-60dBm

- ② Confirm that there is no residual spurious when no connection is made to the input terminal of the spectrum analyzer.
- ③ Confirm that there is no residual spurious when the frequency is changed up to 3.6GHz (2.6GHz for R3261A,C/R3361A,C) with the CENTER FREQ set to 500MHz.

4.3.10 Testing Switchover Stability of Resolution Bandwidth

Procedure

- ① From the preset condition, set the spectrum analyzer as follows:

CENTER FREQ : 30MHz
 FREQ SPAN : 500kHz
 RBW : 300kHz
 REF LEVEL : -15dBm
 dB/div : 1dB/
 CAL SIG : ON

- ② While changing the resolution bandwidth from 1MHz to 30Hz, confirm that the peak level of each spectrum is within ± 0.3 dB of the level at 300kHz resolution bandwidth. Table 4-7 shows that relationship between bandwidth and FREQ SPAN. If the test result falls out of the specification, make adjustments according to "4.4.3 Resolution Band Width Switching Between".

Table 4-7 Relationship Between Resolution Bandwidth and FREQ SPAN

RBW [Hz]	1M	300k	100k	30k	10k	3k	1k	300	100	30
FREQ SPAN [Hz]	2M	500k	200k	50k	20k	5k	2k	1k	1k	1k

4.4 Testing Using Measuring Equipment

4.4.1 Testing Stability of Reference Oscillator

Procedure

- ① Set the REF INT OUT/EXT IN switch on the rear panel of the spectrum analyzer to INT OUT. Connect frequency standard to REF socket on spectrum analyzer through a frequency comparator.

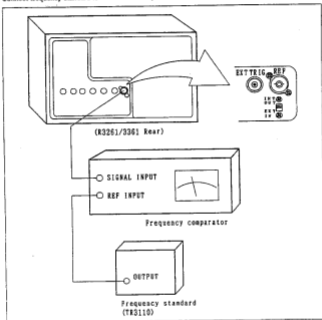

- ② Confirm that the reading on the frequency comparator is 2×10^{-8} or less.

Cont'd

4.4.2 Testing Stability of Center Frequency

Procedure

- ① From the preset condition, set the spectrum analyzer as follows:

CENTER FREQ : 30MHz
FREQ SPAN : 20MHz

- ② Input a 30MHz, -10dBm signal-generated signal to the spectrum analyzer. The signal generator must have stability of 2×10^{-6} or better.
- ③ Confirm that the peak of the spectrum is within $\pm 450\text{kHz}$ (± 0.2 div) of the screen center.
- ④ Set the spectrum analyzer to the following settings, and confirm that the position of the spectrum peak is still within the specification.

Table 4-8 FREQ SPAN and Center Frequency Stability

FREQ SPAN	20MHz	10MHz	2MHz	1 kHz
Specification	$\pm 450\text{kHz}$ ($\pm 0.2\text{div}$)	$\pm 250\text{kHz}$ ($\pm 0.2\text{div}$)	$\pm 60\text{kHz}$ ($\pm 0.3\text{div}$)	$\pm 50\text{Hz}$ ($\pm 0.5\text{div}$)

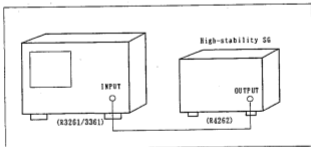

Cont'd

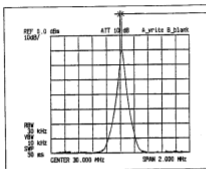

Confirm that the position of the spectrum peak is within the specification

4.4.3 Testing Stability of Frequency Span

Procedure

- ① From the preset condition, set the spectrum analyzer as follows:

CENTER FREQ : 1GHz
FREQ SPAN : 2GHz

- ② Input to the spectrum analyzer a 2GHz, -10dBm signal from an external signal generator.

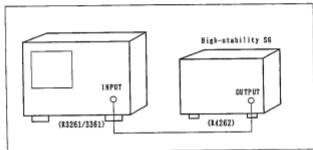

- ③ Adjust the CENTER FREQ so that the zero spectrum is at the left end of the scale.
- ④ Confirm that the difference between the 2GHz spectrum and the right scale end is within ± 0.3 div. (within $\pm 3\%$). If not, make adjustments according to "5.4. 1 (1) Main Span (2GHz)".

Cont'd

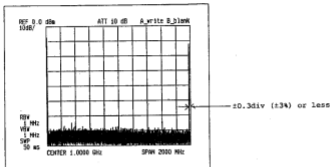

- ⑤ Set the spectrum analyzer as follows:

CENTER FREQ : 5MHz
FREQ SPAN : 10MHz

- ⑥ Adjust the CENTER FREQ so that the peak of the zero spectrum is at the left end of the scale.
- ⑦ Input a 10MHz, -10dBm signal from an external signal generator to the spectrum analyzer. Confirm that the difference between the 10MHz spectrum and the right end of the scale is within ± 0.3 div. ($\pm 3\%$). If not, make adjustments according to "5.4.1 (2) 10MHz SPN".
- ⑧ Set the spectrum analyzer to the following settings:

CENTER FREQ : 1MHz
FREQ SPAN : 2MHz

Then input a 2MHz, -10dBm signal from an external signal generator to the spectrum analyzer. Confirm that the difference between the 2MHz spectrum and the right end of the scale is within ± 0.5 div. ($\pm 5\%$). If not, make adjustments according to "5.4.1 (3) 2MHz SPAN".

4.4.4 Testing LOG Linearity

Procedure

- ① From the preset condition, set the spectrum analyzer as follows:

CENTER FREQ	:	30MHz
SPAN	:	2MHz
R.BW	:	300kHz
REF LEVEL	:	-10dBm
dB/div	:	1dB/div

- ② Connect a signal generator to the spectrum analyzer through an external attenuator.

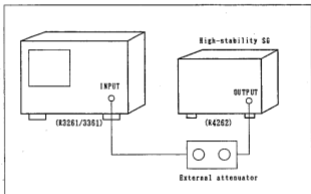

- ③ Input a 30MHz, -10dBm signal from the signal generator to the spectrum analyzer.
- ④ Adjust the output level of the signal generator so that the spectrum peaks at -10dBm when the attenuator is set to 0dB.
- ⑤ Confirm that the deviation in peak level as read on the screen is within $\pm 0.2\text{dB}$ ($\pm 0.2\text{div}$) while the attenuator setting is incremented by 1dB.

Cont'd

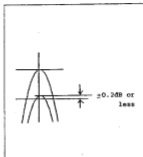
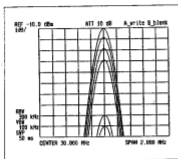

- ⑥ Set the spectrum analyzer to the following settings:

dB/div	:	10dB/
SPAN	:	50kHz
RBW	:	1kHz

- ⑦ Adjust the output level of the signal generator so that the spectrum peaks at -10dBm when the attenuator is set to 0dB.
- ⑧ Confirm that the deviation in peak level as read on the screen is within $\pm 1\text{dB}$ (± 0.1 div) while the attenuator setting is incremented by 10dB.
- ⑨ Confirm that the spectrum peaks at -80dBm $\pm 1.5\text{dB}$ when the attenuator is set to 70dB. If not, make adjustments according to "5.4.5 (1) Adjusting LCG AMP".

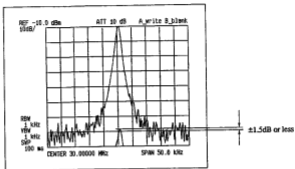

- ⑫ Set the spectrum analyzer to the following settings:

CENTER FREQ	:	50MHz
FREQ SPAN	:	1kHz
RBW	:	30Hz
REF LEVEL	:	-10dBm
12div display		

- ⑬ Input a 50MHz, -10dBm signal from the signal generator to the spectrum analyzer.
- ⑭ Adjust the output level of the signal generator so that the spectrum peaks at -10dBm when the attenuator is set to 0dB.
- ⑮ Confirm that the spectrum peaks at -120dBm \pm 2dB when the attenuator is set to 110dB.

Cont'd

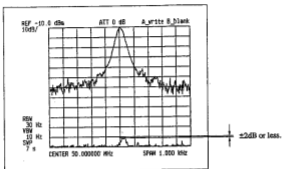

4.4.5 Testing LIN Linearity

Procedure

- ① Set the spectrum analyzer as follows from the preset condition.

CENTER FREQ : 30MHz
SPAN : 2MHz
RBW : 100kHz
REF LEVEL : -10dBm
LINEAR DISPLAY MODE

- ② Connect a signal generator to the spectrum analyzer through an external attenuator.

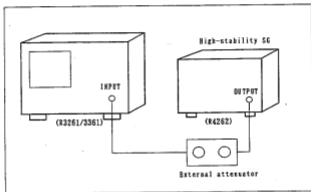

- ③ Set the signal generator so that it puts out a 30MHz, -10dBm signal.
- ④ Adjust the output level of the signal generator so that the spectrum peaks at the uppermost scale on the screen.
- ⑤ Using the marker, read the peak level of the spectrum.
- ⑥ Set the attenuator to 6dB, and read the peak level of the spectrum using the marker.
- ⑦ Obtain the LIN linearity from the values determined in steps ⑤ and ⑥ above. Confirm that the LIN linearity thus obtained is 100±5%.

$$\text{LIN linearity (\%)} = [(\text{value in step ⑥} - \text{value in step ⑤}) / 2] / \text{value in step ⑤} \times 100$$

If the linearity is out of specification, make adjustments according to "5.4.1 (1) Adjusting LOG AMP".

4.4.6 Testing Stability of Reference Level

Procedure

- ① From the preset condition, set the spectrum analyzer as follows:

CENTER FREQ : 30MHz
FREQ SPAN : 5kHz
ATT : 10dB
REF LEVEL : 0dBm

- ② Input a 30MHz, 0dBm signal from a signal generator through an external attenuator to the spectrum analyzer.

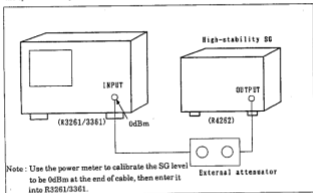

- ③ Set the attenuator to 0dB, and read the peak level of the input waveform using the marker. Confirm that this level is within ± 0.3 dB of the REF LEVEL setting.

Cont'd

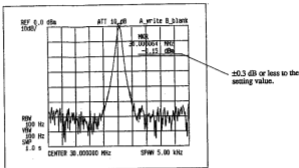

- ④ Change the REF LEVEL and attenuator settings as shown in Table 4-9 and confirm that the deviation from each setting is within $\pm 0.34\text{dB}$ ($\pm 0.7\text{dB}$: REF LEVEL -60dB, -70dB). If not, make adjustments according to "5.4.3 Resolution Band Switching Between".

Table 4-9 REF LEVEL and External Attenuator Settings

REF LEVEL [dBm]	0	-10	-20	-30	-40	-50	-60	-70
External attenuator [dB]	0	10	20	30	40	50	60	70
Specifications [dB]	± 0.3	± 0.3	± 0.3	± 0.3	± 0.3	± 0.3	± 0.7	± 0.7

4.4.7 Testing Stability of Input Attenuator Changeover

Procedure

- 1 Input a 50MHz, -10dBm signal from a signal generator to the spectrum analyzer through an external attenuator set to 40dB.

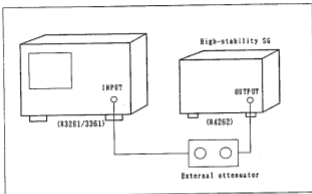

- 2 From the preset condition, set the spectrum analyzer as follows:

CENTER FREQ	:	50MHz
FREQ SPAN	:	10kHz
RBW	:	3kHz
ATT	:	10dB
dB/div	:	1dB
REF LEVEL	:	-45dBm

- 3 Adjust the output level of the signal generator so that the spectrum peaks at the center of the screen.

- 4 Set the external attenuator to 30dB, and set the spectrum analyzer to the following settings:

ATT	:	20dB
REF LEVEL	:	-35dBm

Then confirm that the difference between the current indication and the indication for the 10dB attenuation is with ± 1.0 dB.

Cont'd

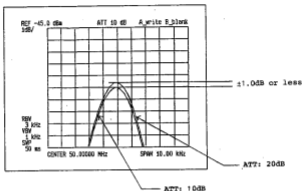

- ③ Change the ATT, external attenuator and REF LEVEL settings as shown in Table 4-10. Confirm that the stability of the input attenuator changeover is within ± 1.0 dB of the 10dB ATT setting.

Table 4-10 Testing Stability of Input Attenuator Changeover

ATT [dB]	10	20	30	40	50
External attenuator [dB]	40	30	20	10	0
REF LEVEL [dBm]	-45	-35	-25	-15	-5

4.4.8 Testing Frequency Response

Procedure

- ① Set the spectrum analyzer as follows from the preset condition:

ATT	:	10dB
dB/div	:	1dB/
CENTER FREQ	:	1GHz
SPAN	:	2GHz
REF LEVEL	:	-15dBm

- ② Input a signal of -20dBm at a frequency of between 100kHz and 2GHz to the spectrum analyzer and confirm that the deviation as read on the screen for each frequency is within ± 0.5 dB.

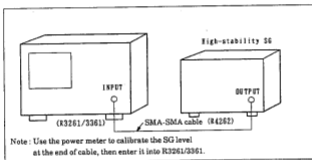

- ③ Set the spectrum analyzer to the following settings:

START FREQ	:	0MHz
STOP FREQ	:	3.6GHz (2.6GHz for R3261A,C/R3361A,C)

- ④ Input to the spectrum analyzer a signal of -20dBm at a frequency between 9kHz and 3.6GHz (2.6GHz for R3261A,C/R3361A,C), and confirm that the deviation as read on the screen for each frequency is within ± 1 dB.

R3261/3361
SPECTRUM ANALYZER
MAINTENANCE MANUAL

4.4 Testing Using existing Equipment

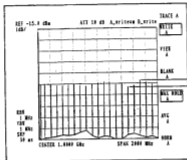

Confirm that the deviation for each frequency is within $\pm 0.5\text{dB}$

4.4.9 Testing Spurious Response

Procedure

- ① From the preset condition, set the spectrum analyzer as follows:

CENTER FREQ : 500MHz
FREQ SPAN : 1000MHz
REF LEVEL : -10dBm
RBW : 1MHz
VBW : 10kHz
ATT : 0dB

- ② Input a signal of -10dBm from a low-distortion signal generator to the spectrum analyzer.
A signal from a signal generator with a low-pass filter capable of reducing the level of the second harmonics by a least 60dB will also work.

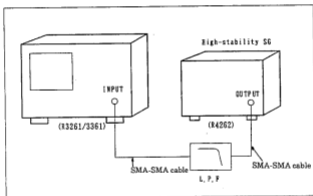

- ③ Change the output frequency of the low-distortion signal generator from 10MHz to 500MHz and confirm that the signal level of the second harmonics is lower than that of the reference waveform by at least 50dB (equivalent to 70dB for -30dBm input).

Cont'd

- ④ For low-distortion signal generator frequencies of 500MHz or over, change the setting of the spectrum analyzer as shown in Table 4-11.

Table 4-11 CENTER FREQ AND SPAN for Dynamic Range Test

Frequency [MHz] SG	R3261A,C/B,D R3361A,C/B,D Set	
	CENTER FREQ [GHz]	SPAN [GHz]
10 to 500	0.5	1
500 to 1000	1.5	1
1000 to 1500 (1300)	2.5	1
1500 to 1800	3.3	0.6

()---R3261A,C/R3361A,C

4.4.10 Testing Stability of Sweep Time

Procedure

- 1 Input a 30MHz, -5dBm, amplitude-modulated signal (100Hz, 30% modulation) from the signal generator to the spectrum analyzer.

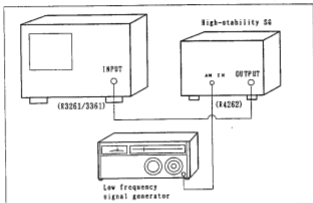

- 2 From the present condition, set the spectrum analyzer as follows:

CENTER FREQ	:	30MHz
SPAN	:	0kHz
RBW	:	30kHz
dB/div	:	1dB
TRIGGER	:	VIDEO
SWEEP TIME	:	50ms

- 3 Confirm that there are 5 cycles $\pm 1/20$ cycles (± 1.5 ms, ± 0.3 div.) of the amplitude-modulated waveform on the screen.

Cont'd

R3261/3361
SPECTRUM ANALYZER
MAINTENANCE MANUAL

4.4 Testing Using Measuring Equipment

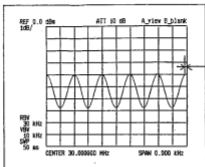

4.4.11 Testing Stability of TG Output Level (For R3361A,C/B,D only)

Procedure

- ① Reset and then set the spectrum analyzer (R3361A,C/B,D only) to the following settings:

CENTER FREQ : 30MHz
FREQ SPAN : 0Hz
TG : ON
TG LEVEL : -10dBm

- ② Connect an RF power meter to the spectrum analyzer at the TG OUTPUT to measure the TG output level. Confirm that the TG output level is $-10\text{dBm} \pm 0.5\text{dB}$. If not, make adjustments according to "5.4.6 (1) Adjusting 1dB Attenuator Output Level Stability".

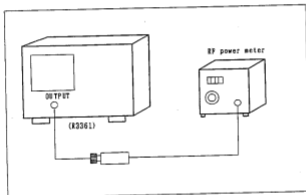

4.4.12 Testing TG Frequency Response (For R3361A,C/B,D only)

Procedure

- ① Reset and then set the spectrum analyzer (R3361A,C/B,D only) to the following settings:

CENTER FREQ	:	30MHz
FREQ SPAN	:	0Hz
TG	:	ON
TG LEVEL	:	-10dBm

- ② Connect an RF power meter with the spectrum analyzer at the TG output.
- ③ Confirm that the TG output level is $\pm 0.7\text{dB}$ for the output level in CENTER FREQ of 30MHz when the CENTER FREQ of the R3361A,C/B,D is changed in a range of 100kHz to 1.0GHz.

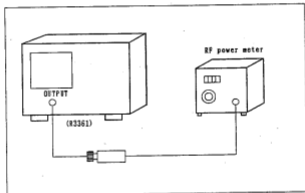

- ④ Confirm that the TG output level is $\pm 1.5\text{dB}$ for the output level in CENTER FREQ of 30MHz when the CENTER FREQ of the spectrum analyzer is changed in a range of 9kHz to 2.6GHz.
- ⑤ Confirm that the TG output level is $\pm 2.0\text{dB}$ for the output level in CENTER FREQ of 30MHz when the CENTER FREQ of the spectrum analyzer is changed in a range of 9kHz to 3.6GHz.

4.4.13 Testing Stability of TG Output Level Changeover (For R3361A,C/B,D only)

Procedure

- ① Reset and then set the spectrum analyzer (R3361A,C/B,D only) to the following settings:

CENTER FREQ : 30MHz
FREQ SPAN : 0Hz
TG : ON
TG LEVEL : -10dBm

- ② Connect an RF power meter to the spectrum analyzer to measure the TG output level.
③ Set the TG LEVEL to -15dBm, and take reading on power meter.
④ Confirm that the difference between the readings of steps②and③above is $5\text{dB} \pm 1\text{dB}$.
⑤ For a range from 0dBm to -50dBm of the TG output level, test according to Table 4-12.

Table 4-12 Stability of TG output Level Changeover

TG LEVEL (dBm)	0	-5	-10	-15	-20	-25	-30	-35	-40	-45	-50
Output level difference at -10dBm setting	+10 ± 1	+5 ± 1	0	-5 ± 1	-10 ± 1	-15 ± 1	-20 ± 1	-25 ± 1	-30 ± 1	-35 ± 1	-40 ± 1

- ⑥ Perform steps ② to ④ for 1.5GHz and 3.0GHz center frequencies. The deviations for 1.5GHz and 3.0GHz must be within $\pm 2\text{dB}$ and $\pm 3\text{dB}$ respectively.

4.4.14 Testing Output Spurious (For R3361A,C/B,D only)

Procedure

- ① Reset and then set the spectrum analyzer (R3361A,C/B,D only) to the following settings:

CENTER FREQ	:	30MHz
FREQ SPAN	:	0Hz
TG	:	ON
TG LEVEL	:	0dBm

- ② Connect an external spectrum analyzer to the R3361A,C/B,D at the TG OUTPUT.

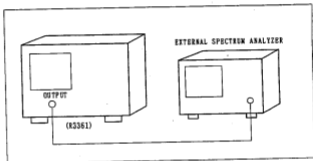

- ③ Change the center frequency to up to 3.6GHz for the R3361B/D, or 2.6GHz for the R3361A/C, and confirm that the harmonics spurious is lower than the basic waveform by at least -20dBc and that the non-harmonics spurious is lower by at least -30dBc.

4.4.15 Testing TG Leak (For R3361A,C/B,D only)

Procedure

- ① Reset and then set the spectrum analyzer (R3361A,C/B,D only) to the following settings:

REF LEVEL : -80dBm
SWP TIME : 50sec
RBW : 100Hz
VBW : 1Hz
ATT : 0dB
TG : ON
TG LEVEL : 0dBm

- ② Execute the TG FREQ CAL (AUTO) to compensate for any tracking error. Make no connection to the INPUT or TG OUTPUT connector.
- ③ Confirm that TG leak is not more than -110dBm for up to 3GHz, and not more than -100dBm for up to 3.6GHz.

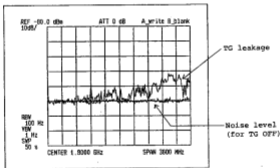

4.5 Test Report

The test report form for the spectrum analyzer is given below.

R3261A,C/B,D R3361A,C/B,D Test Report

Item		Specification	Measurement
1. CAL signal test			
1. CAL signal level		-20dBm \pm 0.3dB	dBm
2. Test using CAL signals			
1. Noise side band	20kHz offset	-105dBc/Hz	dBc/Hz
2. Frequency drift		300Hz/min	
3. Stability of resolution bandwidth (3dB bandwidth)	RBW 1MHz	\pm 20%	%
	RBW 300kHz		%
	RBW 3kHz		%
4. Resolution bandwidth selectivity (60dB : 3dB)	RBW 1MHz	15 : 1	:
	RBW 300kHz		:
	RBW 3kHz		:
5. QP bandwidth stability (6dB bandwidth)	QP 120kHz	110kHz to 130kHz	kHz
	QP 9kHz	8kHz to 10kHz	kHz
	QP 200Hz	170Hz to 230Hz	Hz
6. Marker indication stability (normal mode)	SPAN 20MHz	\pm 1.05MHz	MHz
	SPAN 10MHz	\pm 550kHz	kHz
	SPAN 2MHz	\pm 160kHz	kHz
7. Marker indication stability (counter mode)	SPAN 20Hz	\pm 1Hz	Hz
8. Average noise level		-121dBm + 1.55f	dBm
9. Residual response		-100dBm	dBm
10. Switchover stability of resolution bandwidth		\pm 0.3dB	dB

R3261A,C/B,D R3361A,C/B,D Test Report (Cont'd)

Item	Specification	Measurement
3. Test Using measuring equipment		
1. Reference oscillator stability	$\pm 2 \times 10^{-8}$	x10
2. Center frequency stability	SPAN 20MHz	$\pm 450\text{kHz}$
	SPAN 10MHz	$\pm 250\text{kHz}$
	SPAN 2MHz	$\pm 60\text{kHz}$
	SPAN 1kHz	$\pm 50\text{Hz}$
3. Frequency span stability	SPAN 2GHz	$\pm 3\%$
	SPAN 10MHz	$\pm 3\%$
	SPAN 2MHz	$\pm 5\%$
4. LOG linearity		$\pm 0.2\text{dB}/1\text{dB}$
		$\pm 1.0\text{dB}/10\text{dB}$
		$\pm 1.5\text{dB}/70\text{dB}$
		$\pm 2.0\text{dB}/110\text{dB}$
5. LIN linearity	$\pm 5\%$ of Full Scale	%
6. Reference level stability	REF 0dBm to -50dBm	$\pm 0.3\text{dB}$
	REF -60dBm to -70dBm	$\pm 0.7\text{dB}$
7. Input attenuator changeover stability	$\pm 1.0\text{dB}$	dB
8. Frequency response	100kHz to 2GHz	$\pm 0.5\text{dB}$
	9kHz to 3.6GHz	$\pm 1\text{dB}$
9. Spurious response	-10dBm INPUT	-50dBc
10. Sweep time stability	$\pm 3\%$	%
11. TG output level stability	$\pm 0.5\text{dB}$	dB

R3261/3361
SPECTRUM ANALYZER
MAINTENANCE MANUAL

4.5 Test Report

R3261A,C/B,D R3361A,C/B,D Test Report (Cont'd)

Item	Specification	Measurement	
12. TG output frequency response	100kHz to 1GHz	$\pm 0.7\text{dB}$	dB
	9kHz to 2.6GHz	$\pm 1.5\text{dB}$	dB
	9kHz to 3.6GHz	$\pm 2.0\text{dB}$	dB
13. Stability of TG output level changeover	100kHz to 1GHz	$\pm 1.0\text{dB}$	dB
	9kHz to 2.6GHz	$\pm 2.0\text{dB}$	dB
	9kHz to 3.6GHz	$\pm 3.0\text{dB}$	dB
14. Output spurious	Harmonics spurious	-20dB	dB
	Non-harmonic spurious	-30dB	dB
15. TG leakage	to 3.0GHz	-110dBm	dBm
	to 3.6GHz	-100dBm	dBm

MEMO 

R3561/0361
SPECTRUM ANALYZER
MAINTENANCE MANUAL

5. ADJUSTMENTS

5. ADJUSTMENTS

5.1 Measurement Standards & Support Test Equipment Performance Requirements

5.1 Measurement Standards & Support Test Equipment Performance Requirements

Minimum-Use-Specifications (MUS) are the calculated minimum performance specifications criteria needed for the Measurement Standards (MS) and Support Measuring & Test Equipment (S-M & TE) to be used for the comparison measurements required in the Adjustment Procedure (AP) process.

The MUS is developed through uncertainty analysis and is calculated through assignment of a defines and documented uncertainty/accuracy ratio or margin between the specified tolerances of the UUT and the capability (uncertainty specification) required of the measurement standards system. MUS is required to assist a measurement specialist in the evaluation of existing or selection of alternate measurement standards equipment.

CAUTION

The instructions in this AP relate specifically to the equipment and conditions listed in Section 5.2. If other equipment is substituted, the information and instructions must be interpreted and revised accordingly.

MS and S-M & TE Environmental Range : Temperature ; 18°C to 28°C
Relative Humidity ; 30 to 70%

MS and S-M & TE Warm-up/Stabilisation Period Requirements : 2 Hours

R3361/3361
SPECTRUM ANALYZER
MAINTENANCE MANUAL

5.1 Measurement Standards & Support Test Equipment Performance Requirements

Table 5-1 Measurement Standards (MS) Performance Requirements

Equipment Generic Name (Quantity)	Minimum Use Specifications (MUS)	Manufacturer/Model /Option Applicable
Frequency standard	Output frequency: 10 MHz Stability: 5×10^{-16} /day Output impedance: Approx. 50 Ω Output voltage: 1 Vp-p or more	TR3110
Frequency comparator	Frequency: 10 MHz 1×10^{-9} frequency detectable	
Synthesized signal generator	Frequency range: 10 MHz to 4 GHz Residual SSB phase noise: 1 kHz offset < -115 dBc/Hz 10 kHz offset < -125 dBc/Hz 100 kHz offset < -130 dBc/Hz Power level range: -100 to +10 dBm	R4262
Spectrum analyzer	Frequency range: Up to 100 MHz With built-in TG	R3361A, C/B,D
Power meter	Accuracy: ± 0.02 dB Decibel relative mode	HP436A
Digital multimeter	DC voltage resolution: 5 digits or more	TR6851
Power sensor	Frequency range: 10 MHz to 18 GHz Power range: 1μ W to 100 mW	HP8481A
Impedance generator		R14602

83261/8361
SPECTRUM ANALYZER
MAINTENANCE MANUAL

5.1 Measurement Standards & Support Test Equipment Performance Requirements

Table 5-2 Support Measuring & Test Equipment (S-M&TE) Performance Requirements

Equipment Generic Name (Quantity)	Minimum Use Specifications (MUS)	Manufacturer /Model/Option Applicable
Cable	Length: 150 cm Connection: BNC (male) at both ends	MI-09
Cable	Frequency range: DC to 26.5 GHz Maximum SWR: < 1.45 at 26.5 GHz Length: Approx. 76 cm Connector: SMA (male) at both ends	A01002
Cable	Frequency: 21.4 MHz Length: 100 cm Connector: UM (male), BNC (male)	MC-36A
Adapter	Type N (male) to SMA (female)	HRM-554S
Adapter	Type N (male) to BNC (female)	JUG-201A/U (Hirose)
Probe	Frequency: 3.5789 MHz 10:1 Impedance: 10 MHz	P6133 (Tektronix)

R3261/0361
SPECTRUM ANALYZER
MAINTENANCE MANUAL

5.2 Preliminary Operations

5.2 Preliminary Operations

WARNING

Always make sure spectrum analyzer's power supply cord is plugged into a 3-hole grounded outlet or 2-hole outlet with grounded adapter. You can be fatally shocked if you fail to follow this rule.

Do not touch live circuits when calibrating instrument.

- (1) Review this entire procedure before starting calibration procedure.
- (2) Always operate the instrument on AC 100V (120V, 200V, 220V, or 240V) \pm 10% with a line frequency of 50Hz or 60Hz.
- (3) Always confirm that the POWER switch is OFF before connecting the power cable to the AC line.
- (4) Spectrum analyzer has a self-calibration function. This function compensates for adjusting shift caused by change with age of software. For calibration, turn off this function.

Operation Procedure :

SHIFT

7

CAL COOR

ON/OFF

(SOFT KEY 8)

5.3 Calibration Process

LOCATION

(1) IF (BLQ-015668)



R32610361
SPECTRUM ANALYZER
MAINTENANCE MANUAL

5.3 Calibration Process

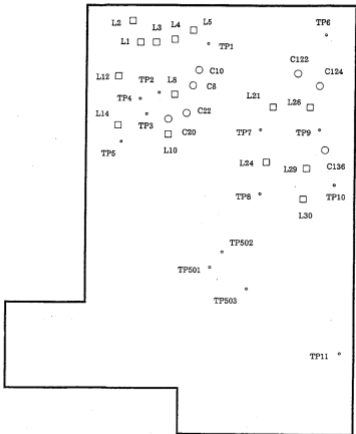

R32610361
SPECTRUM ANALYZER
MAINTENANCE MANUAL

5.3 Calibration Process

(2) RF CONT (BLL-015672)

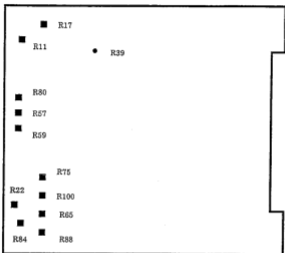

(3) ALC CONT (BLC-015680)

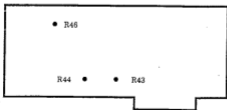

(4) CAL AMP (BLB-015646)



(5) YTO DRIVER (BLB-015647)

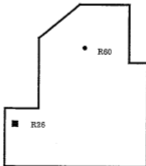

5.3.1 Center Frequency Accuracy Adjustment

(1) 10MHz Frequency Reference Adjustment

- DESCRIPTION

Connect the signal cable between the 10MHz terminal of the Frequency Standard unit and the Frequency Comparator unit. Also, connect the cable between the 10MHz REF OUT terminal at the rear panel of R3261/3361 and the Frequency Comparator unit. Adjust the internal crystal oscillator of the R3261/3361 by comparing the signal.

- EQUIPMENT

Frequency Standard unit TR3110

Frequency Comparator (supporting 10MHz, 1×10^{-9} signal detection)

Cables BNC (male), 150cm long MI-09 (TWO)

- CONNECTION

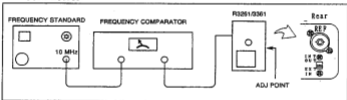

- ASSEMBLY ADJUSTED

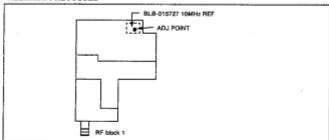

• PROCEDURE

Note: Allow the R3261/3361 warm up for at least 30 minutes before performing this adjustment.

- ① Remove the lower cover of R3261/3361 and then connect the equipment as shown in the figure of CONNECTION.
- ② Set the 10MHz REF of the R3261/3361 to INT.
Change the rear panel S.W.

CAUTION

When the 10MHz reference is set to EXT, the crystal oscillator is not warmed up. If the reference is set to EXT, set the reference to INT and allow 30 minutes for the crystal oscillator warm up.

- ③ Adjust the 10MHz REF so that the indicator of frequency comparator reaches within $\pm 1 \times 10^{-4}$.
ADJ 10MHz REF (BLB-015727)
 - ④ Attach the cover.
- (2) YTO ADJUSTMENT

• DESCRIPTION

Adjust the offset tune of YTO with the center frequency set to 0Hz and 3.6GHz, respectively. The first local PLL must be turned off.

• EQUIPMENT

High-stability SG	(to 3.6GHz or to 2.4GHz)	R4262
Cables	SMA (male), 70cm long	AA01002
Adapters	N (male) to SMA (female), HRM-554S	(TWO)

Use the adapter assembly of the impedance 75Ω for N type R3261/3361.

• CONNECTION

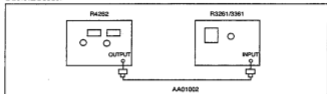

• ASSEMBLY ADJUSTMENT

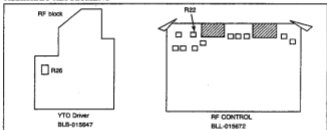

• PROCEDURE

① Remove the cover of R3261/3361 to connect as shown in the figure of CONNECTION.

② Pull out the J3 connector on RF CONT, BLL-015672.
Short 5PIN and 6PIN in J3.

③ Power on SG and R3261/3361 and warm up them for a while.

④ Setting SG

f: 3.6GHz (B type), 2.6GHz (A type)

Po: -20dBm

⑤ Setting R3261/3361 (After pressing the **PRESET** key)

SPAN: 20MHz

SPAN 20 MHz

R3261/3361
SPECTRUM ANALYZER
MAINTENANCE MANUAL

5.3 Calibration Process

- ⑥ Set the **CENTER FREQUENCY** to 0Hz on R3261/3361.

CENT FREQ 0 Hz

Adjust R62 until the spectrum becomes 0Hz \pm 1MHz.

ADJ YTO driver (BLB-015647) R26

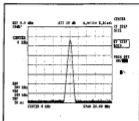

- ⑦ Set the **CENTER FREQUENCY** to 3.6GHz (for B type) and 2.6GHz (for A type), respectively, on R3261/3361.

CENT FREQ 3 . 6 GHz (B type)

or

CENT FREQ 2 . 6 GHz (A type)

Adjust R80 until the frequency of SG becomes \pm 1MHz.

ADJ RF CONT (BLL-015672) R80

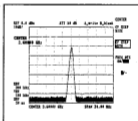

- ⑧ Repeat ⑥ and ⑦ until each specification is met.
⑨ Turn the power on and connect the J3 connector to the original position.

5.3.2 Frequency Span Adjustment

- DESCRIPTION

Display two spectrums by using the SG signal and a local feed through. Adjust the MAIN SPAN and each span of 10MHz, 2MHz and Log with variable resistor.

- EQUIPMENT

High-stability SG	(to 3.6GHz or to 2.4GHz)	R4262
Cables	SMA (male), 70cm long	AA01002
Adapters	N (male) to SMA (female), HRM-554S	(TWO)

Use the adapter assembly of the impedance 75Ω for N type R3261/3361.

- CONNECTION

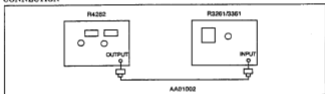

- ASSEMBLY ADJUSTMENT

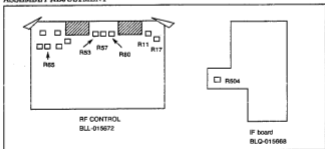

(1) MAIN SPAN

● PROCEDURE

① Remove the cover and connect as shown in the figure of CONNECTION.

② Setting SG

f: 3.24GHz (B type)

2.34GHz (A type)

Pc: -20dBm

Setting R3261/3361 (After pressing the **PRESET** key)

SWP: 500ms



③ Calibration of frequency span of R3261/3361

Adjust the local feedthrough (0Hz spectrum) with VR R504 to the scale left end. Adjust frequency span from the scale left end to 9dev with R22 adding the signal from SG.

ADJ IF board (BLQ-015668) R504 *OFFSET
RF CONTROL (BLI-015672) R22 *GAIN

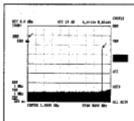

(2) 10MHz SPAN

• PROCEDURE

① The connection is the same with the MAIN SPAN adjustment.

② Setting SG

f: 8MHz

Po: -20dBm

③ Setting R3261/3361 (After pressing the **PRESET** key)

CENT FREQ: 4MHz

CENT FREQ 4 **MHz**

SPAN: 10MHz

SPAN 1 0 **MHz**

SWP: 500ms

CPL **SWP** ↑ ↑ ↑

④ Adjust R57 so that each spectrum of 0Hz and 8MHz may be positioned on the scale that is one division away from each end of the screen on R3261/3361.

ADJ RP CONTROL R57

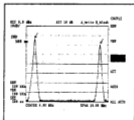

(3) 2MHz SPAN

● PROCEDURE

① The connection is the same with the MAIN SPAN adjustment.

② Setting SG

f: 1.6MHz

Po: -20dBm

③ Setting R3261/3361 (After pressing the **PRESET** key)

CENT FREQ: 800kHz

CENT FREQ 8 0 0 kHz

SPAN: 2MHz

SPAN 2 MHz

SWP: 500ms

CPL SWP ↑ ↑ ↑

④ Adjust R53 so that each spectrum of 0Hz and 1.6MHz may be positioned on the scale that is one division away from each end of the screen on R3261/3361.

ADJ RP CONTROL R53

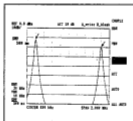

(4) LOG SPAN

● PROCEDURE

① The connection is the same with the MAIN SPAN adjustment.

② Setting R3261/3361 (After pressing the **PRESET** key)

SPAN: LOG 100 MHz to 1000MHz

SPAN **LOG**

Marker: PEAK SEARCH ON

PEAK **NEXT** **PEAK CONT**
MENU **ON/OFF**

③ Setting SG

f: 200MHz

Po: -20dBm

Adjust R17 until the marker value becomes
200MHz \pm 5MHz on R3261/3361.

ADJ RF CONTROL (BLL-015672) R17

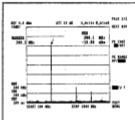

④ Changing the SG setting

f: 900MHz

Adjust R11 until the marker value becomes
900MHz \pm 5MHz on R3261/3361.

ADJ RF CONTROL R11

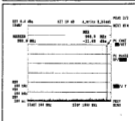

⑤ Repeat ③ and ④ until each specification is met.

⑥ Reinstall the cover.

5.3.3 Resolution Bandwidth Accuracy Adjustment

- DESCRIPTION

IF filter consists of eight band-pass filters; four of them are made of L and C; others are made of a crystal filter.

Resolution waveforms of the IF filter can be observed with an external spectrum analyzer possessing TG.

- EQUIPMENT

External Spectrum Analyzer with TG .. R3361A, C/B, D
Impedance converter R14602
10M Ω Probe P6133
Cables UM-BNC, 100cm long MC-36A
Adapters N (male) to BNC (female), JUG-201 A/U

- CONNECTION

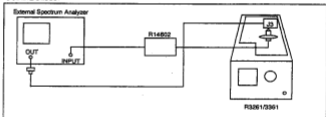

R3261/3361
SPECTRUM ANALYZER
MAINTENANCE MANUAL

5.3 Calibration Process

● ASSEMBLY ADJUSTMENT

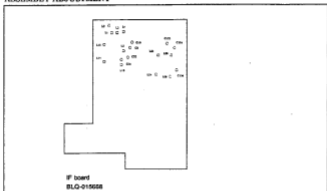

● PROCEDURE

- ① Remove the upper cover of R3261/3361 and then remove the shield case of the IF board.
- ② Connect TG Out of external spectrum analyzer to IF board (BLQ-015668) J3.
- ③ Connect the 10MΩ probe to input of the external spectrum analyzer passing the impedance converter, and set as follows:

CENTER FREQ: 3.5789MHz

TG LEVEL: -20dBm

- ④ Setting R3261/3361 (After pressing the **PRESET** key)

CAL CORRECTION: OFF

SHIFT **1** **CAL CORR**
ON/OFF

R3261/3361
SPECTRUM ANALYZER
MAINTENANCE MANUAL

5.3 Calibration Process

- ⑤ Connect the 10M Ω probe to IF board (BLQ-015668) TP1, and observe the form of 3.5789MHz band-pass filter. Adjust L1, L2, L3 and L4 so that the center frequency is 3.5789MHz and symmetrical.
(Refer to circuit 2/38)

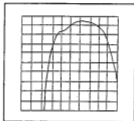

- ⑥ Connect 10M Ω probe to TP4. Set the external spectrum analyzer and the R3261/3361 spectrum analyzer as follows:
- External spectrum analyzer
FREQ SPAN: 200kHz
 - R3261/3361

RBW: 10kHz

CPL	RBW	1	0	kHz
-----	-----	---	---	-----

SPAN: 10MHz

SPAN	1	0	MHz
------	---	---	-----

- ⑦ Adjust so that the peak of TP4 waveform is 3.5789MHz.
ADJ IF board (BLQ-015668) L12 (circuit 4/38)



R3261/3361
SPECTRUM ANALYZER
MAINTENANCE MANUAL

5.3 Calibration Process

- ⑤ Connect 10M Ω probe to TP5, adjust so that the peak of TP5 waveform is 3.5789MHz.

ADJ IF board

L14 (circuit 4/38)



- ⑥ Connect 10M Ω probe to TP2. Set the spectrum analyzer as follows:

R3261/3361

RBW: 3kHz



- ⑦ Adjust so that peak of TP2 waveform is 3.5789MHz.

ADJ IF board

L8

(circuit 3/38)



Also adjust so that the waveform is symmetrical.

ADJ IF board

C8

(circuit 3/38)



Repeat the adjustment several times till both are satisfied.

R3261/3361
SPECTRUM ANALYZER
MAINTENANCE MANUAL

5.3 Calibration Process

- ① Connect the 10M Ω probe to TP3 and adjust so that peak of TP3 waveform is 3.5789MHz.
ADJ IF board L10 (circuit 3/38)

FREQ ADJ



Also adjust so that the waveform is symmetrical.

ADJ IF board C20 (circuit 3/38)

SYMMETRI



Repeat the adjustment several times till both are satisfied.

- ② Connect the 10M Ω probe to TP2. Set the spectrum analyzer as follows:

R3261/3361

RBW: 30Hz

3	0	Hz
---	---	----

Adjust so that peak of TP2 waveform is 3.5789MHz.

ADJ IF board C10 (circuit 3/38)

FREQ ADJ



R3261/3361
SPECTRUM ANALYZER
MAINTENANCE MANUAL

5.3 Calibration Process

- ⑤ Connect the 10M Ω probe to TP3 and adjust so that peak of TP3 waveform is 3.5789MHz.

ADJ IF board C22 (circuit 3/38)



- ⑥ Connect the 10M Ω probe to TP7. Set the spectrum analyzer as follows:

R3261/3361

RBW: 10kHz

1 0 kHz

Adjust so that the peak of TP7 waveform is 3.5789MHz.

ADJ IF board L21 (circuit 10/38)



- ⑦ Connect 10M Ω probe to TP8 and adjust so that the peak of TP8 waveform is 3.5789MHz.

ADJ IF board L24 (circuit 10/38)



R3261/3361
SPECTRUM ANALYZER
MAINTENANCE MANUAL

5.3 Calibration Process

- ⑥ Connect 10M Ω probe to TP9. Set the spectrum analyzer as follows:

R3261/3361

RBW: 3kHz

3	kHz
---	-----

- ⑦ Adjust so that the peak of TP9 waveform is 3.5789MHz.

ADJ IF board L26 (circuit 11/38)

FREQ ADJ



Also adjust so that the waveform is symmetrical.

ADJ IF board C124 (circuit 11/38)

SYMMETRI



Repeat the adjustment several times till both are satisfied.

R32610361
SPECTRUM ANALYZER
MAINTENANCE MANUAL

5.3 Calibration Process

- ④ Connect 10M Ω probe to TP10 and adjust so that peak of TP10 waveform is 3.5789MHz.

ADJ IF board L29 (circuit 11/38)



Also adjust so that the waveform is symmetrical.

ADJ IF board C136 (circuit 11/38)



Repeat the adjustment several times till both are satisfied.

R3261/3361
SPECTRUM ANALYZER
MAINTENANCE MANUAL

5.3 Calibration Process

- ② Connect the 10M Ω probe to TP9. Set the spectrum analyzer as follows:

R3261/3361

RBW: 30Hz

3	0	Hz
---	---	----

Adjust so that peak of TP9 waveform is 3.5789MHz.

ADJ IF board C122 (circuit 11/38)

FREQ ADJ



- ② Connect the 10M Ω probe to TP10, and adjust so that peak of TP3 waveform is 3.5789MHz.

ADJ IF board C124 (circuit 11/38)

FREQ ADJ



- ③ Remove the input cable connected to the external spectrum analyzer and then connect the J3 connector to the original position.

5.3.4 Resolution Band Width Switching Between Adjustment

• DESCRIPTION

One IF filter in two IF filter group is adjusted with another spectrum analyzer with TG function. Another IF filter group is adjusted with the screen of R3261/3361. Each RBW of 10kHz, 3kHz and 30Hz is adjusted based on RBW of 300kHz.

• EQUIPMENT

External Spectrum Analyzer with TG	..	R3361A, C/B, D	
Impedance converter	R14602	
10MΩ Probe	P6133	
Cables	UM-BNC, 100cm long	MC-36A
Adapters	N (male) to BNC (female),	JUG-201 A/U

• CONNECTION

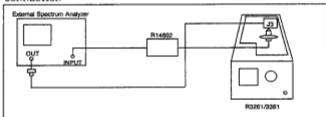

• ASSEMBLY ADJUSTMENT

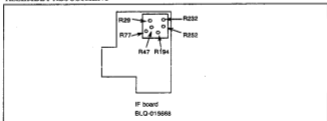

R3261/3361
SPECTRUM ANALYZER
MAINTENANCE MANUAL

5.3 Calibration Process

(1) IP-1

- ① Remove the upper cover of R3261/3361 and then remove the shield case of the IF board.
- ② Connect TG out of external spectrum analyzer to IF board (BLQ-015668) J3.
- ③ Connect the 10M Ω probe to input of the external spectrum analyzer passing the impedance converter, and set as follows:

CENTER FREQ: 3.5789MHz
TG LEVEL: -20dBm
SPAN: 200kHz
RBW: 100kHz
dB/div: 0.1dB/div

- ④ Setting R3261/3361 (After pressing the **PRESET** key)

CAL CORRECTION: OFF

SHIFT **1** **CAL CORR**
ON/OFF

RBW: 300kHz

CPL **RBW** **3** **0** **0** **kHz**

- ⑤ Connect the 10M Ω probe to IF board (BLQ-015668) TP5 and read the peak value of waveform.
- ⑥ Set the spectrum analyzer as follows:

R3261/3361

RBW: 10kHz

1 **0** **kHz**



Adjust so that the peak level of the filter is the same as that of RBW at 300kHz above.

ADJ IF board(BLQ-015668) R77 (Refer to circuit 4/38)

R3261/3361
SPECTRUM ANALYZER
MAINTENANCE MANUAL

5.3 Calibration Process

- ⑦ Connect 10M Ω probe to TP5 and set the external spectrum analyzer and the spectrum analyzer as follows:

- a) External spectrum analyzer

SPAN: 5kHz

- b) R3261/3361

RBW: 3 kHz

3 kHz

Read the peak value of waveform.

- ⑧ Set the spectrum analyzer as follows:

R3261/3361

RBW: 30Hz

3 0 Hz



Adjust so that the peak level of the filter is the same as that of RBW at 3kHz above.

ADJ IF board R29 (circuit 3/38)

- ⑨ Set the external spectrum analyzer and the spectrum analyzer as follows:

- a) External spectrum analyzer

SPAN: 100kHz

- b) R3261/3361

RBW: 300kHz

3 0 0 kHz

Read the peak value of waveform.

R3261/3361
SPECTRUM ANALYZER
MAINTENANCE MANUAL

5.3 Calibration Process

- ① Set the spectrum analyzer as follows:

R3261/3361

RBW: 3kHz

3	kHz
---	-----

LEVEL ADJ



Adjust so that the peak level is the same as that of RBW at 300kHz above.

ADJ IF board R47 (circuit 3/38)

- ② Remove the input cable connected to the external spectrum analyzer and then connect the J3 connector to the original position.

(2) IF-2

- ① Remove the upper cover of R3261/3361 and then remove the shield case of the IF board.

- ② Setting R3261/3361 (After pressing the **PRESET** key)

CENTER FREQ: 30MHz

CENTER FREQ 3 0 MHz

SPAN: 200kHz

SPAN 2 0 0 kHz

RBW: 300kHz

CPL RBW 3 0 0 kHz

REF LEVEL: -19.5dBm

REF LEVEL 1 9 . 5 -dBm

dB/div 0.1dB/

dB/div ↓ ↓ ↓ ↓ ↓ ↓

CAL SIGNAL: ON

SHIFT 1 CAL SIG
ON/OFF

CAL CORRECTION: OFF

CAL CORR
ON/OFF

Read the peak level of waveform.

- ③ Set the spectrum analyzer as follows:

R3261/3361

RBW: 10kHz

CPL RBW 1 0 kHz

SPAN: 20kHz

SPAN 2 0 kHz

Adjust so that the peak level of filter is the same as that of RBW at 300kHz above.

ADJ IF board R194 (circuit 10/38)

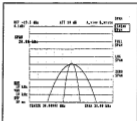

- ④ Set the spectrum analyzer as follows:

R3261/3361

RBW: 3kHz

CPL RBW 3 kHz

SPAN: 5kHz

SPAN 5 kHz

Read the peak level of waveform.

- ⑤ Set the spectrum analyzer as follows:

R3261/3361

RBW: 30Hz

CPL RBW 3 0 Hz

SPAN: 1kHz

SPAN 1 kHz

Adjust so that the peak level of filter is the same as that of RBW at 3kHz above.

ADJ IF board R232 (circuit 11/38)

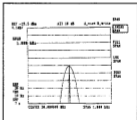

R3261/3361
SPECTRUM ANALYZER
MAINTENANCE MANUAL

5.3 Calibration Process

- ⑥ Set the spectrum analyzer as follows:

R3261/3361

RBW: 300kHz

CPL RBW 3 0 0 kHz

SPAN: 200kHz

SPAN 2 0 0 kHz

Read the peak level of waveform.

- ⑦ Set the spectrum analyzer as follows:

R3261/3361

RBW: 3kHz

CPL RBW 3 kHz

SPAN: 5kHz

SPAN 5 kHz

Adjust to maximize the peak of waveform filter.

ADJ IF board L30 (circuit 12/38)



- ⑧ Adjust so that the peak level of filter is the same as that of RBW at 300kHz above.

ADJ IF board R252 (circuit 11/38)

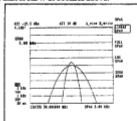

- ⑨ Reinstall the shield case and then reinstall the upper cover of R3261/3361.

5.3.5 LOG/LINEAR Amplifier Linearity Adjustment

- DESCRIPTION
The LOG/LIN GAIN, OFFSET, MAG AMP, QP DET value can be adjust by changing the variable resistor values.
- EQUIPMENT

High stability SG	R4252
10dB step ATT (0dB to 70dB)	
Power meter	HP436A
Power sensor (3.5789MHz)	HP8481A
Digital multimeter	TR6851
Cables	BNC (male), 150cm long MI-09
	UM-BNC, 100cm long MC-36A
Adapters	N (male) to BNC (female), JUG-201 A/U (Three)
- CONNECTION

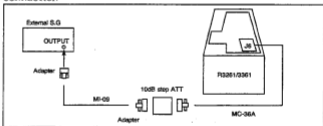

• ASSEMBLY ADJUSTMENT



- ① Remove the top cover of the R3261/3361, and connect the signal generator as shown in the figure of CONNECTION.

Note: Before connecting, set the signal generator to 3.5789MHz, and calibrate with the power meter so that the signal generator inputs -14dBm into J6. (Set the 10dB step attenuator to 0dB.)

SG

f: 3.5789MHz

Pc: -20dBm

- ② Setting R3261/3361: (LINER MODE) (After pressing the **PRESET** key)

SPAN: 0Hz

CAL CORRECTION: OFF

REF LEVEL: LINER

RBW: 3kHz

R3261/3361
SPECTRUM ANALYZER
MAINTENANCE MANUAL

5.3 Calibration Process

- ③ Set the 10dB step attenuator to 80dB, and adjust the volume control until the voltage of TP11 becomes 0 to 1mV. (TP503 is grounded.)

ADJ IF board (BLQ-015668) R326

- ④ Set the 10dB step attenuator to 30dB, and measure the voltage of U54 5-pin with the digital multimeter (Data ①). Next, adjust the volume control until the voltage of TP12 becomes Data ① \pm 1mV.

ADJ IF board R465

- ⑤ Adjust the volume control until the voltage of U52 6-pin becomes 40.0 to 40.5mV.

ADJ IF board R473

- ⑥ Set the 10dB step attenuator to 0dB, and adjust the volume control until the voltage of TP11 becomes 4V \pm 3mV.

ADJ IF board R298

- ⑦ Setting the R3261/3361: (LOG MODE)

REF LEVEL: LOG

REF Log/div

- ⑧ Set the 10dB step attenuator to 0dB, and adjust the volume control until the voltage of JP2 becomes 4V \pm 3mV.

ADJ IF board R301

- ⑨ Set the 10dB step attenuator to 70dB, and adjust the volume control until the voltage of JP2 becomes 0.5V \pm 3mV.

ADJ IF board R347

- ⑩ Repeat steps ⑧ and ⑨ until the conditions therein are satisfied.

- ⑪ Set the 10dB step attenuator to 0dB. (dB/div ADJ)

- ⑫ Change the scale unit to 1dB/div, and adjust the volume control until the voltage of JP2 becomes 4V \pm 3mV.

1dB/div

REF dB/div ↓ ↓ ↓

ADJ IF board R360

R3261/3361
SPECTRUM ANALYZER
MAINTENANCE MANUAL

5.3 Calibration Process

- ② Change the scale unit to 10dB/div, and adjust the volume control until the voltage of JP2 becomes $4V \pm 3mV$.

10dB/div
REF dB/div ↑ ↑ ↑
ADJ IP board R370

- ③ Repeat steps ② and ③ until the conditions therein are satisfied.
④ Setting the R3261/3361: (QP MODE ADJ)

QP: ON
SHIFT 4 QP
 ON/OFF

- ⑤ Set the 10dB step attenuator to 0dB, and adjust the volume control until the voltage of JP2 becomes $4V \pm 3mV$.

ADJ IP board R397

- ⑥ Set the 10dB step attenuator to 30dB, and adjust the volume control until the voltage of JP2 becomes $2.48V \pm 10mV$.

ADJ IP board R400

- ⑦ Repeat steps ⑤ and ⑥ until the conditions therein are satisfied.
⑧ Disconnect the input cable from J6, and reestablish the connection in its former state. Set the signal output level from the signal generator to $-5dBm$, and connect the input cable to J3 on the IP board. Set the 10dB step attenuator to 0dB.

SG setting
Po: $-5dBm$

- ⑨ See that the R3261/3361 outputs the marker onto the scale, and adjust the signal output level from the signal generator until the marker level becomes 0dBm.

Marker: ON

- ⑩ Set the 10dB step attenuator to 40dB, and adjust the volume control until the marker indicates $-40dBm \pm 0.5dB$.

ADJ IP board R467

- ⑪ Set the 10dB step attenuator to 70dB, and adjust the volume control until the marker indicates $-40dBm \pm 0.5dB$.

ADJ IP board R467

R3261/3361
SPECTRUM ANALYZER
MAINTENANCE MANUAL

5.3 Calibration Process

④ Repeat steps ① and ② until the conditions therein are satisfied.

⑤ Setting R3261/3361: (IF GAIN ADJ) (After pressing the **PRESET** key)

SPAN: 0Hz

SPAN **ZERO SPAN**

CAL CORRECTION: OFF

SHIFT **1** **CAL CORR ON/OFF**

RBW: 300kHz

CPL **RBW** **3** **0** **0** **kHz**

Marker: **ON**

dB/div: 1dB/div

REF **dB/div** **↓** **↓** **↓**

⑥ Calibrate the signal level so that a -5dBm signal is input from the signal generator into J3. Input the signal from the signal generator into J3 again.

⑦ Adjust the volume control until the marker level becomes $0\text{dBm} \pm 0.5\text{dB}$.

ADJ IF board R5

LEVEL ADJ



⑧ Disconnect the input cable from J3, and reestablish the connection in its former state.

5.3.6 Reference Level Adjustment

(1) STEP AMP

- DESCRIPTION

The IF step amp consists of five amps: one that can be changed between 10dB and 20dB, and four 20dB amps. The gain of these amps can be adjusted using the volume control. For adjustment, the reference signal and a signal differing from the reference signal by 10dB or 20dB are used. The difference between these two signal levels must have first been calibrated.

- EQUIPMENT

High stability SG	R4262
10dB step ATT (0dB to 70dB)	
Cables	SMA, 70cm long A01002
Adapters	N (male) to SMA (female), HRM-554S (Four)

Use the adapter assembly of the impedance 75Ω for N type R3261/3361.

- CONNECTION

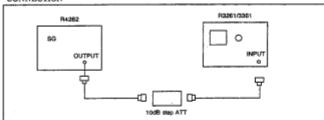

● ASSEMBLY ADJUSTMENT

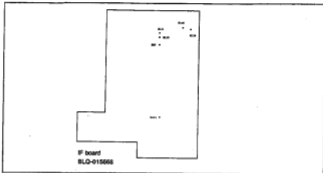

- ① Remove the top cover of the R3261/3361, and connect the signal generator as shown in the figure of CONNECTION.
- ② Turn on the power, and allow a warmup period of at least 30 minutes.
- ③ Setting R3261/3361 (After pressing the **PRESET** key)

CAL CORRECTION: OFF

SHIFT **1** **CAL CORR**
OFF

CENT FREQ: 30MHz

CENT **FREQ** **3** **0** **MHz**

SPAN: 50kHz

SPAN **5** **0** **kHz**

RBW: 3kHz

CPL **3** **kHz**

dB/div: 0.2dB

REF **dB/div** **↓** **↓** **↓** **↓** **↓**

Marker: PEAK SEARCH (CONT)

PEAK **NEXT** **PEAK CONT**
MENU **ON/OFF**

④ SG Setting

f: 30MHz

Po: -1dBm

- ⓐ Adjust the marker value of R3261/3361 by changing the signal level of SG for -1dBm.
- ⓑ Set the 10dB step attenuator and the reference level to 10dB and -10dBm, respectively. Adjust the volume control until the marker level becomes $-11\text{dBm} \pm 0.05\text{dB}$.

REF LEVEL: -10dBm



ADJ IF board R111

LEVEL ADJ



- ⓓ Change the reference level and the setting of the 10dB step attenuator as shown in the table, and adjust the volume control in the same manner as ⓑ above.

REF 10dB down
 10dB up

REF LEVEL	10dB step ATT	VR for ADJ	ADJ Spec
-10dBm	10dB	R 111	$-11\text{dBm} \pm 0.03\text{dB}$
-20dBm	20dB	R 97	$-21\text{dBm} \pm 0.03\text{dB}$
-40dBm	40dB	R 110	$-41\text{dBm} \pm 0.03\text{dB}$
-50dBm	50dB	R 149	$-51\text{dBm} \pm 0.03\text{dB}$
-70dBm*	70dB	R 159	$-71\text{dBm} \pm 0.03\text{dB}$

* REF LEVEL -70dBm setting

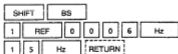

② 120dB display adjustment



10dB step ATT 0dB

Adjust until the signal output level from the signal generator becomes 0dBm on the R3261/3361.

- ③ Set the 10dB step attenuator to 60dB, and adjust until the marker level becomes -60dBm \pm 1.6dB.

ADJ IP board R414

LEVEL ADJ



(2) RF Total Gain Adjustment

• DESCRIPTION

RF Total Gain of R3261/3361 and internal Calibration signal are adjusted, using the external signals of 30MHz and -20dBm from the signal generator as a reference.

• EQUIPMENT

High stability SG	R4262	
Power meter	HP436A	
Power sensor	HP8481A	
Cables	SMA, 70cm long	A01002
Adapters	N (male) to SMA (female),	HRM-554S (TWO)

Use the adapter assembly of the impedance 75Ω for N type R3261/3361.

R3261/3361
SPECTRUM ANALYZER
MAINTENANCE MANUAL

5.3 Calibration Process

• CONNECTION

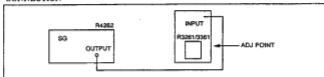

• ASSEMBLY ADJUSTMENT

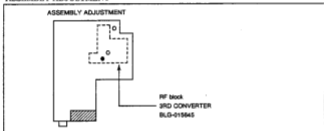

- ① Remove the bottom cover of the R3261/3361, and input the following signals from the signal generator (after first calibrating them with the power meter).

SG

f: 30MHz

Po: -20dBm

R3261/3361
SPECTRUM ANALYZER
MAINTENANCE MANUAL

5.3 Calibration Process

- ② Setting R3261/3361 (After pressing the **PRESET** key)

CENT FREQ: 30MHz

CENT FREQ 3 0 MHz

SPAN: 500kHz

SPAN 5 0 0 kHz

RBW: 300kHz

CPL RBW 3 0 0 kHz

REF LEVEL: -15dBm

REF 1 5 -dBm

dB/div: 1dB/div

dB/div ↓ ↓ ↓

CAL CORRECTION: OFF

REF 1 CAL CORR ON/OFF

MARKER: PEAK SEARCH (CONT)

PEAK NEXT PEAK CONT ON/OFF

- ③ Adjust the volume control until the marker level becomes $-20\text{dBm} \pm 0.1\text{dB}$.

ADJ 3RD CONV R28

LEVEL ADJ



④ Calibration Amp Adjustment

Disconnect the input cable from the signal generator, calibrate the following signals with the power meter, and input them to the R3261/3361 again.

SG

f: 30MHz

Pe: -30dBm

Uncover the shield case of the calibration amp block.

⑤ Setting the R3261/3361:

REP LEVEL: -25dBm



Measure the signal level from the signal generator with the marker. (Data ①)

⑥ Turn the calibration amp on, and set the calibration signal level to -30dBm. Then adjust the volume control until the marker level becomes Data ① ± 0.05 dBm.

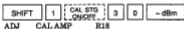

LEVEL ADJ



⑦ Set the calibration signal level to -20dBm, and adjust the volume control until the marker level becomes 20dBm ± 0.05 dB.



LEVEL ADJ



⑧ Put the bottom cover of the R3261/3361 back in place.

5.3.7 TG Output Level Accuracy

- DESCRIPTION

Set the TG output level to 30MHz, measure the output with the power meter, and adjust the measurement using the volume control.

- EQUIPMENT

Power meter HP 436A

Power sensor HP 8481A

Use the adapter assembly of the impedance 75Ω for N type R3261/3361.

- CONNECTION

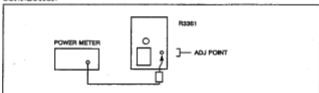

- ASSEMBLY ADJUSTMENT

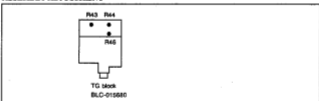

R3261/3361
SPECTRUM ANALYZER
MAINTENANCE MANUAL

5.3 Calibration Process

- ① Setting R3261/3361 (After pressing the **PRESET** key)

CENT FREQ: 30MHz

CENT FREQ MHz

SPAN: 0Hz

SPAN

TG: ON

TG

CAL CORRECTION: OFF

SHIFT

- ② Remove the bottom cover of the R3261/3361, and connect the power meter as shown in the figure of CONNECTION.
- ③ Adjust the two volume controls so that the variable range on the power meter becomes $4\text{dB} \pm 0.1\text{dB}$ when the output level of the TG block is changed from -14dBm to -10dBm .



ADJ ALC CONT (BLC-015680) R43, R46

- ④ Set the output level of the TG block to -10dBm , and adjust with the volume control until the power meter reads $-10\text{dBm} \pm 0.1\text{dB}$.

TG LEVEL: -10dBm

-dBm

ADJ ALC CONT R44

R3261/3361
SPECTRUM ANALYZER
MAINTENANCE MANUAL

6.2 Unlock

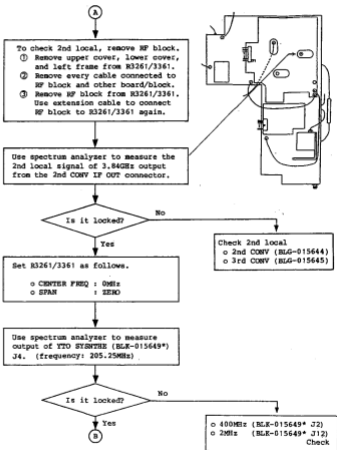

*BLK-015649: Refer to figure 3-23.

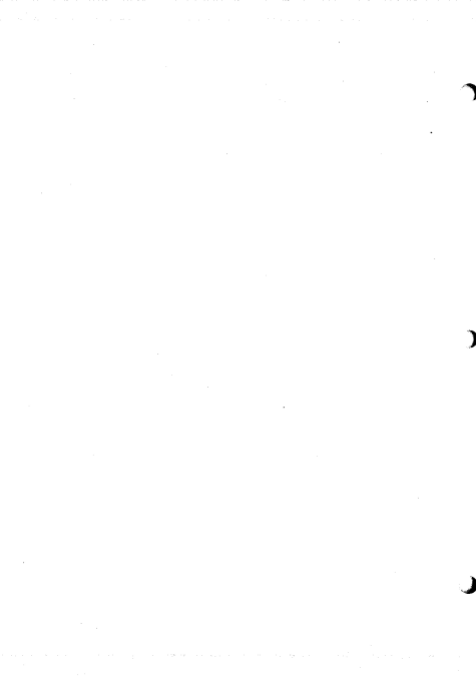

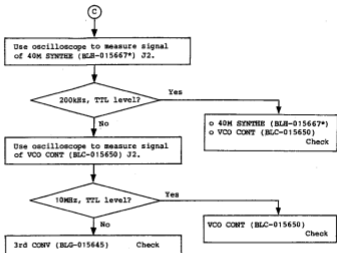

*BLG-015667: Refer to figure 3-23.

6.3 TG Failure

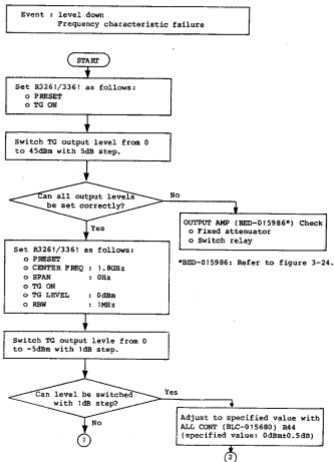

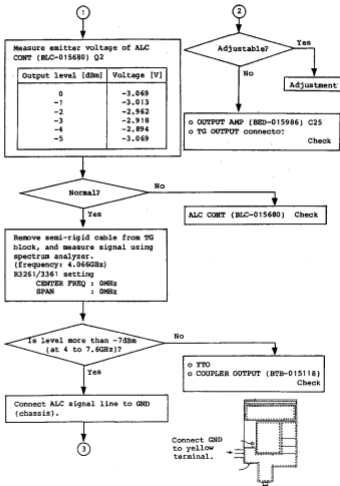

R3261/3361
SPECTRUM ANALYZER
MAINTENANCE MANUAL

6.3 TG Failure

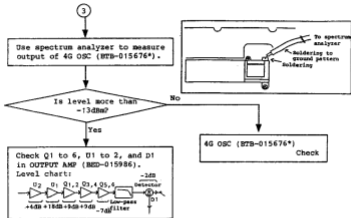

*BTB-015676: Refer to figure 3-24.

6.4 Power Supply

Replace the power supply unit if does not work correctly.

Procedure

- ① Replace the power supply unit. (See Figure 6-3.)
- ② Check that the voltage check points (+15V, -15V, +5.2V and +12V) shown in Figure 6-1 are within the following tolerances:

+15V --- $\pm 5\%$
-15V --- $\pm 5\%$
+5.2V --- $\pm 3\%$
+12V --- $\pm 5\%$

- ③ Make the adjustments described in 5.4.1 "Frequency Span".
- ④ Make the adjustments described in 5.4.5 "LOG/LINEAR Amplifier Linearity".

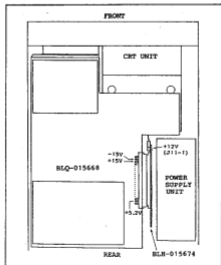

Figure 6-1 Voltage Check Points

6.5 CRT Unit

Replace the CRT unit if it does not work correctly.

Procedure

- ① Replace the CRT unit. (See Figure 6-3.)
- ② Set the intensity to the maximum value with INTENSITY.
- ③ Adjust the intensity with "SUB BRIGHT" (See Figure 6-2.) so that the back raster appears faintly.
- ④ Adjust "CONTRAST" to strengthen the contrast (See Figure 6-2.) as far as the pattern is not distorted remarkably and can be focused.

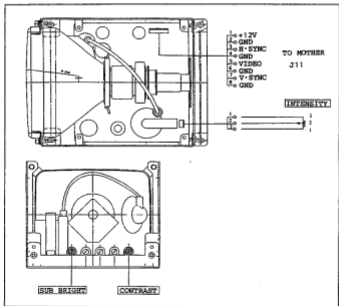

Figure 6-2 Fine Adjustment of The CRT Unit

7. REPLACEABLE ELECTRICAL PARTS, CIRCUIT DIAGRAMS AND LOCATION

Table 7-1 Contents for Chapter 7

	BOARD NAME	PCB ASSEMBLY	PARTS LIST	CIRCUIT LAYOUT	PARTS LOCATION	CIRCUIT DIAGRAM
	IC CARD	BGC-015745	7-2	-	7-3	7-4 to 7-5
	CONTROL	BLQ-015670	7-7 to 7-8	-	7-9	7-10 to 7-28
	RF CONTROL	BLL-015672	7-27 to 7-30	7-31	7-32	7-33 to 7-34
	IF SECTION	BLQ-015688	7-35 to 7-54	7-55	7-56	7-57 to 7-94
	CPU	BLQ-015689	7-95 to 7-98	-	7-99	7-100 to 7-132
	TG KEY	BLB-015775	7-133	-	-	7-135
	KEY	BLG-015673	7-137	-	7-139	7-140 to 7-141
R F	RF BLOCK	WBL-3261RF	7-143	7-145	7-146	7-149
		WBL-3361RF	7-144	7-147	7-148	
	CAL AMP	BLB-015646	7-151	7-145	7-146	7-153
	YTO DRIVER	BLB-015647	7-156 to 7-158	7-157	7-158	7-159 to 7-180
	10MHz REF.	BLB-015727	7-161	7-147	7-148	7-183
	SAMPLER	BTB-016118	7-165	7-145	7-146	7-167 to 7-168
	VCO CONT	BLC-015650	7-169 to 7-170	7-145	7-146	7-171
	3RD CONV	BLG-016645	7-173 to 7-180	7-145	7-146	7-181 to 7-183
	YTO SYNTH	BLK-015649	7-185 to 7-192	7-145	7-146	7-193 to 7-196
	INPUT ATT	BTB-015641	7-197	7-145	7-146	7-199
	1ST MIXER	BTB-015642	7-201	7-145	7-146	7-203
	2ND CONV	BDT-015644	7-205 to 7-207	7-145	7-146	7-209 to 7-210
	T G	TG BLOCK	WBL-3361TG	7-211	7-213 7-215	7-214 7-216
OUTPUT AMP		BED-015996	7-219 to 7-221	7-215	7-216	7-223
TG SAMPLER		BLB-015987	7-225	7-213	7-214	7-227
ALC CONT.		BLC-015680	7-229 to 7-230	7-215	7-216	7-231
T.G CONT.		BLD-015681	7-233	7-235	-	7-236
TG PLL		BLC-015988	7-237 to 7-238	7-213	7-214	7-239
4GHZ OSC		BTB-015676	7-241	7-215	7-216	7-243
TG MIX-1		BTB-015722	7-245	7-213	7-214	7-247
TG MIX-2		BTB-015723	7-249	7-213	7-214	7-251
MOTHER		BLH-015674	7-253	-	-	7-255 to 7-256
BATT. HOLDER	BLB-016053	7-257	-	-	7-259	

R3261/3361
 IC CARD
 BLO-015745 (1/1)

Parts No.	Advantest Stock No.	Description	Note
C1-4	CSM-AGR1U50V	FXD CER 0.1 μ F +80%, -20% 50V	
C5	CSM-AGR1U50V	FXD CER 0.1 μ F +80%, -20% 50V	
D1	NLD-000001	LED	
J1	JCR-AF026PX02	CONNECTOR	
J2	SEE-MZE8101AAA	CONNECTOR	
Q1	STP-2SA842-33	TRANSISTOR PNP	
Q2	STN-RN1002	TRANSISTOR NPN	
R1	RCB-AG56K	FXD CAR 56K Ω \pm 5% 1/8W	
R2	RCB-AG560	FXD CAR 560 Ω \pm 5% 1/8W	
R3	RCB-AG1K	FXD CAR 1K Ω \pm 5% 1/8W	
R4	RAY-AL100K4	FXD RA 100K Ω \pm 5%	
U1	SIM-74HC245S	OCTAL BUS TRANSCEIVERS	
U2	SIM-74HC541S	OCTAL BUFFERS & LINE DRIVERS	
U3	SIM-74HC74S	DUAL D FLIP-FLOPS WITH RESET & CLEAR	
U4	SIM-74HC10S	TRIPLE 3-INPUT POSITIVE-NAND	
U5	SIT-74LS375S	4-BIT BISTABLE LATCHES	
U6	SIM-74HC02S	QUAD 2-INPUT POSITIVE NOR	
U7	SIM-74HC04S	HEX INVERTERS	

R3261/3361
CONTROL
BLQ-015670 (1/2)

Parts No.	Advantest Stock No.	Description	Notes
B1	DEE-001129	BUZZER	
C1	CCK-BX10U25V	FXD ELECT 10 μ F \pm 20% 25V	
C3	CCK-BX100U35V	FXD ELECT 100 μ F \pm 20% 35V	
C5	CCK-BX10U25V	FXD ELECT 10 μ F \pm 20% 25V	
C7	CSM-AGR1U50V	FXD CER 0.1 μ F \pm 20% 50V	
C27	CCK-BX10U16V	FXD ELECT 10 μ F \pm 20% 16V	
C28	CSM-AGR1U50V	FXD CER 0.1 μ F \pm 20% 50V	
C30	CCK-BX10U16V	FXD ELECT 10 μ F \pm 20% 16V	
C31	CSM-AGR1U50V	FXD CER 0.1 μ F \pm 20% 50V	
C35	CCK-BX10U16V	FXD ELECT 10 μ F \pm 20% 16V	
C36	CSM-AGR1U50V	FXD CER 0.1 μ F \pm 20% 50V	
D1	SDZ-H3-8	ZENER DIODE	
D2	NLD-000016	LED	
J1	JCS-BC006PX01	CONNECTOR	
J2	JCR-AF026PX02	CONNECTOR	
J3	JCP-AA012PX07	CONNECTOR	
J4	JCR-AF034PX02	CONNECTOR	
L1	LCL-C00010	COIL 180 μ H \pm 10%	
L2	LCL-T00084A	COIL (CUSTOM DEVICE)	
L3	LCL-C00010	COIL 180 μ H \pm 10%	
Q1	STN-29C1815	TRANSISTOR NPN	
R1	RAY-TL1K4	FXD RA 1k Ω x 4 \pm 5% 1/8W	
R2	RCB-AG1R5K	FXD CAR 1.5k Ω \pm 5% 1/8W	
R3	RCB-AG10K	FXD CAR 10k Ω \pm 5% 1/8W	
R4	RCB-AG1K	FXD CAR 1k Ω \pm 5% 1/8W	
R6	RAY-TL3RBK3	FXD RA 3.9k Ω x 3 \pm 5% 1/8W	
R12	RAY-BGX0015	FXD RA \pm 20%	
R14	RCB-AG8R8K	FXD CAR 8.8k Ω \pm 5% 1/8W	
R15	RCB-AG3R3K	FXD CAR 3.3k Ω \pm 5% 1/8W	
R16	RCB-AG1K	FXD CAR 1k Ω \pm 5% 1/8W	
U1	SIM-74HC244	OCTAL BUFFERS	
U3	SIM-74HC652	OCTAL BUS TRANCEIVERS & REGISTERS	
U5	SIT-75188	QUAD LINE DRIVER	
U6	SIM-74HC125	QUAD BUS BUFFER GATES	
U7	SIM-74HC04	HEX INVERTERS	
U8	SIM-74HC74	DUAL D FLIP-FLOPS WITH PRESET & CLEAR	
U10	SIM-74HC139	DUAL 2 TO 4-LINE DECODERS	
U11	SIM-74HC138	3 TO 8-LINE DECODERS	
U13	SIM-74HC00	QUAD 2 INPUT POSI-NAND GATES	
U14	SIM-74HC32	QUAD 2 INPUT POSI-OR GATES	

R3261/3361
CONTROL
BLQ-015670 (2/2)

Parts No.	Advantest Stock No.	Description	Note
U15	SIM-74HC06	QUAD 2 INPUT POSI-AND GATES	
U16	SIM-74HC32	QUAD 2 INPUT POSI-OR GATES	
U17	SIM-74HC74	DUAL D FLIP-FLOPS WITH PRESET & CLEAR	
U18	SMM-51812BAL10	131072-WORD x 3-BIT PSEUDO STATIC RAM	
U20	SIM-74HC32	QUAD 2 INPUT POSI-OR GATES	
U21	SIM-74HC125	QUAD BUS BUFFER GATES	
U22	SIM-74HC32	QUAD 2 INPUT POSI-OR GATES	
U23	SMM-51812BAL10	131072-WORD x 3-BIT PSEUDO STATIC RAM	
U25	SIM-74HC04	HEX INVERTER	
U26	SIM-74HC32	QUAD 2 INPUT POSI-OR GATES	
U27	SIM-74HC107	DUAL J K FLIP-FLOPS WITH CLEAR	
U28	SIM-74HC164	8-BIT PARALLEL OUTPUT SERIAL SHIFT REGISTERS	
U29	SIM-74HC157	QUAD 2 TO 1 LINE DATA SELECTORS	
U30	SIM-74HC05	HEX INVERTERS (OPEN DRAIN)	
U31	SIM-654815	DECODER & CLOCK GENERATORS	
U32	SMM-27C1001A	131072-WORD x 8-BIT EPROM	
U33	SMM-27C1001A	131072-WORD x 8-BIT EPROM	
U34	SIM-8254C	PROGRAMMABLE COUNTER/TIMER	
U35	SIM-74HC06	QUAD 2 INPUT POSI-AND GATES	
U36	SIM-74HC74	DUAL D FLIP-FLOPS WITH PRESET & CLEAR	
U37	SMM-27C1001A	131072-WORD x 8-BIT EPROM	
U38	SMM-27C1001A	131072-WORD x 8-BIT EPROM	
U39	SIM-74HC32	QUAD 2 INPUT POSI-OR GATES	
U40	SIM-74HC574	OCTAL D FLIP-FLOPS	
U42	SIM-8251	SERIAL COMMUNICATION INTERFACE	
U43	SIM-8914	GP AB CONTROLLER	
U44	SIT-74LS245	OCTAL BUS TRANSCEIVERS	
U46	SIT-74LS841	OCTAL BUS TRANSCEIVERS (OPEN COLLECTOR)	
U48	SIT-75189	QUAD LINE RECEIVERS	
U49	SIT-75182	OCTAL GP AB TRANSCEIVERS	
U50	SIT-75180	OCTAL GP AB TRANSCEIVERS	
U51	SIM-68HC000C	16-BIT MICROPROCESSOR	

R3261/3361
RF CONT
BLQ-015672 (1/4)

Parts No.	Advantest Stock No.	Description					Note
C1-2	CSM-AGR1U50V	FXD	CER	0.1 μ F	+80%,-20%	50V	
C6	CSM-AC1000P50V	FXD	CER	1000PF	\pm 10%	50V	
C7-8	CTA-AB2R2U35V	FXD	TA	2.2 μ F	\pm 20%	35V	
C9	CFM-AHR1U100V-1	FXD	FILM	0.1 μ F	\pm 10%	100V	
C10	CFM-ASR022U50V	FXD	FILM	0.022 μ F	\pm 10%	50V	
C11	CSM-AGR1U50V	FXD	CER	0.1 μ F	+80%,-20%	50V	
C12	CFM-ASR033U50V	FXD	FILM	0.033 μ F	\pm 10%	50V	
C13-14	CTA-AB2R2U35V	FXD	TA	2.2 μ F	\pm 20%	35V	
C15-18	CSM-AGR1U50V	FXD	CER	0.1 μ F	+80%,-20%	50V	
C19	CSM-BA2200P50V	FXD	CER	2200PF	\pm 5%	50V	
C20-21	CSM-AGR1U50V	FXD	CER	0.1 μ F	+80%,-20%	50V	
C22	CCK-AR100U16V	FXD	ELECT	100 μ F	\pm 20%	16V	
C23-24	CTA-AB2R2U35V	FXD	TA	2.2 μ F	\pm 20%	35V	
C25	CTA-ABR47U35V	FXD	TA	0.47 μ F	\pm 20%	50V	
C26	CTA-AC1U50V	FXD	TA	1 μ F	\pm 20%	50V	
C27	CTA-AB2R2U35V	FXD	TA	2.2 μ F	\pm 20%	35V	
C28	CSM-AGR1U50V	FXD	CER	0.1 μ F	+80%,-20%	50V	
C29-34	CTA-AB2R2U35V	FXD	TA	2.2 μ F	\pm 20%	35V	
C35-39	CSM-AGR1U50V	FXD	CER	0.1 μ F	\pm 20%	50V	
C40-41	CTA-AC3R3U16V	FXD	TA	3.3 μ F	\pm 20%	16V	
C42	CCK-AR100U16V	FXD	ELECT	100 μ F	\pm 20%	10V	
C43-44	CTA-AC3R3U16V	FXD	TA	3.3 μ F	\pm 20%	16V	
C45-46	CCK-AR47U25V	FXD	ELECT	47 μ F	\pm 20%	25V	
C47	CCK-AR47U25V	FXD	ELECT	47 μ F	\pm 20%	25V	
C48	CCK-BX47U25V	FXD	ELECT	47 μ F	\pm 20%	25V	
C49	CSM-AC33P50V	FXD	CER	33PF	\pm 10%	50V	
C51	CSM-BA330P50V	FXD	CER	330PF	\pm 5%	50V	
D2	SDS-1S953		DIODE SI				
D3	SDZ-W130		ZENER DIODE				
D4	SDZ-2-2		ZENER DIODE				
D7	SDS-1SS101		DIODE SI				
D8	SDZ-D030		ZENER DIODE				
J1	JCS-9C0096PX01		CONNECTOR				
J2	JCR-AF028PX02		CONNECTOR				
J3	JCS-AD010PX02		CONNECTOR				
L1-3	LCL-C00013		COIL (CUSTOM DEVICE)				
L4	LCL-C00358		COIL (CUSTOM DEVICE)				
Q2	STP-2SA642-33		TRANSISTOR PNP				
Q3	STN-2SC1815-55		TRANSISTOR NPN				
Q4	STP-2SA642-33		TRANSISTOR PNP				
Q5	STN-2SC815-2		TRANSISTOR NPN				
Q6	STP-2SA1015		TRANSISTOR PNP				
R1	RCB-AG820K		FXD CAR	820K Ω	\pm 5%	1/8W	
R2-3	RMF-AC10KFJ		FXD FILM	10K Ω	\pm 1%	1/4W	
R22	RVR-CD2K		VAR CERMET	2K Ω	\pm 20%	1/2W	
R23	RMF-AC19R1KFJ		FXD METAL	19.1K Ω	\pm 1%	1/4W	
R24	RMF-AC10KFJ		FXD METAL	10K Ω	\pm 1%	1/4W	

R3261/3361
RF CONT
BLQ-015672 (2/4)

Parts No.	Advantest Stock No.	Description				Note
R25	RMF-AC1KFJ	FXD	METAL	1K Ω	$\pm 1\%$	1/4W
R26	RMF-AC1100FJ	FXD	METAL	110 Ω	$\pm 1\%$	1/4W
R27-28	RCB-AG1R6K	FXD	CAR	1.5K Ω	$\pm 5\%$	1/8W
R29	RMF-AC10KFJ	FXD	METAL	10K Ω	$\pm 1\%$	1/4W
R30	RMF-AC3R3KFJ	FXD	METAL	3.3K Ω	$\pm 1\%$	1/4W
R31	RMF-AB5KFG	FXD	METAL	5K Ω	$\pm 1\%$	1/4W
R32	RVR-8E2K	VAR		2K Ω	$\pm 10\%$	1/2W
R33	RMF-AB9R1KFG	FXD	METAL	9.1K Ω	$\pm 1\%$	1/4W
R34-35	RCB-AG10K	FXD	CAR	10K Ω	$\pm 5\%$	1/8W
R36	RMF-AC1R2KFJ	FXD	METAL	1.2K Ω	$\pm 1\%$	1/4W
R37	RCB-AG2R2K	FXD	CAR	2.2K Ω	$\pm 5\%$	1/8W
R38	RMF-AC4R7KFJ	FXD	METAL	4.7K Ω	$\pm 1\%$	1/4W
R39	RVR-DF1K	VAR		1K Ω	$\pm 20\%$	1/2W
R40	RMF-AC3R9KFJ	FXD	METAL	3.9K Ω	$\pm 1\%$	1/4W
R41	RMF-AC12KFJ	FXD	METAL	12K Ω	$\pm 1\%$	1/4W
R42-43	RMF-AC10KFJ	FXD	METAL	10K Ω	$\pm 1\%$	1/4W
R44	RMF-AC3R3KFJ	FXD	METAL	3.3K Ω	$\pm 1\%$	1/4W
R45-46	RMF-AC10KFJ	FXD	METAL	10K Ω	$\pm 1\%$	1/4W
R47	RCB-AG10K	FXD	CAR	10K Ω	$\pm 5\%$	1/8W
R48	RCB-AG3R3K	FXD	CAR	3.3K Ω	$\pm 5\%$	1/8W
R49	RCB-AG220	FXD	CAR	220 Ω	$\pm 5\%$	1/8W
R50	RCB-AG10K	FXD	CAR	10K Ω	$\pm 5\%$	1/8W
R51	RMF-AC10KFJ	FXD	METAL	10K Ω	$\pm 1\%$	1/4W
R52	RMF-AC8R2KFJ	FXD	METAL	8.2K Ω	$\pm 1\%$	1/4W
R53	RVR-CD10K	VAR	CERMET	10K Ω	$\pm 20\%$	1/2W
R54	RCB-AG220	FXD	CAR	220 Ω	$\pm 5\%$	1/8W
R55	RMF-AC12KFJ	FXD	METAL	12K Ω	$\pm 1\%$	1/4W
R56	RMF-AC14KFG	FXD	METAL	14K Ω	$\pm 1\%$	1/4W
R57	RVR-CD5K	VAR	CERMET	5K Ω	$\pm 20\%$	1/2W
R58	RCB-AG820K	FXD	CAR	820K Ω	$\pm 5\%$	1/8W
R59	RMF-AC27KFJ	FXD	METAL	27K Ω	$\pm 1\%$	1/4W
R60-61	RMF-AC4R7KFJ	FXD	METAL	4.7K Ω	$\pm 1\%$	1/4W
R62	RMF-AC470KFJ	FXD	METAL	470K Ω	$\pm 1\%$	1/4W
R63	RCB-AG1M	FXD	CAR	1M Ω	$\pm 5\%$	1/8W
R64	RCB-AG560K	FXD	CAR	560K Ω	$\pm 5\%$	1/8W
R65	RVR-CD10K	VAR	CERMET	10K Ω	$\pm 20\%$	1/2W
R66	RMF-AC12KFJ	FXD	METAL	12K Ω	$\pm 1\%$	1/4W
R67	RMF-AC10KFJ	FXD	METAL	10K Ω	$\pm 1\%$	1/4W
R68	RCB-AG1K	FXD	CAR	1K Ω	$\pm 5\%$	1/8W
R69	RCB-AG18K	FXD	CAR	18K Ω	$\pm 5\%$	1/8W
R70	RCB-AG5R6K	FXD	CAR	5.6K Ω	$\pm 5\%$	1/8W
R71	RCB-AG10K	FXD	CAR	10K Ω	$\pm 5\%$	1/8W
R72	RMF-AC33KFJ	FXD	METAL	33K Ω	$\pm 1\%$	1/4W
R73	RMF-AC680KFJ	FXD	METAL	680K Ω	$\pm 1\%$	1/4W
R74	RCB-AG10K	FXD	CAR	10K Ω	$\pm 5\%$	1/8W
R75	RVR-CD50K	VAR	CERMET	50K Ω	$\pm 20\%$	1/2W
R76	RCB-AG3R3K	FXD	CAR	3.3K Ω	$\pm 1\%$	1/8W
R77	RCB-AG15K	FXD	CAR	15K Ω	$\pm 5\%$	1/8W
R78	RCB-AG10K	FXD	CAR	10K Ω	$\pm 5\%$	1/8W
R79	RCB-AG1K	FXD	CAR	1K Ω	$\pm 5\%$	1/8W
R80	RVR-BD2K	VAR		2K Ω	$\pm 10\%$	1/2W
R81	RMF-AB8R2KFG	FXD	METAL	8.2K Ω	$\pm 1\%$	1/4W

R3261/3361
RF CONT
BLQ-015672 (3/4)

Parts No.	Advantest Stock No.	Description	Note
R82	RMF-AB5R6KFG	FXD METAL 5.6KΩ ±1%	1/4W
R83	RMF-AC1R2KFJ	FXD METAL 1.2KΩ ±1%	1/4W
R84	RVR-CD20K	VAR CERMET 20KΩ ±20%	1/2W
R85	RMF-AC39KFJ	FXD METAL 39KΩ ±1%	1/4W
R86	RMF-AC27KFJ	FXD METAL 27KΩ ±1%	1/4W
R87	RMF-AC18QFJ	FXD METAL 18KΩ ±1%	1/4W
R88	RVR-CD50K	VAR CERMET 50KΩ ±20%	1/2W
R89	RMF-AC100KFJ	FXD METAL 100KΩ ±1%	1/4W
R90	RMF-AC39KFJ	FXD METAL 3.9KΩ ±1%	1/4W
R91	RMF-AC220QFJ	FXD METAL 220Ω ±1%	1/4W
R94	RCB-AG47K	FXD CAR 47KΩ ±5%	1/8W
R95-96	RCB-AG10K	FXD CAR 10KΩ ±5%	1/8W
R97	RMF-AB1KFG	FXD METAL 1KΩ ±1%	1/4W
R98	RMF-AC22KFJ	FXD METAL 22KΩ ±1%	1/4W
R99	RMF-AC33KFJ	FXD METAL 33KΩ ±1%	1/4W
R100	RVR-CD100K	VAR CERMET 100KΩ ±20%	1/2W
R101	RMF-AC20KFJ	FXD METAL 20KΩ ±1%	1/4W
R102	RMF-AC4R7KFJ	FXD METAL 4.7KΩ ±1%	1/4W
R103-105	RMF-AC4R7KFJ	FXD METAL 4.7KΩ ±1%	1/4W
U1-2	SIM-74HC138	3 TO 8-LINE DECODERS	
U3	SIM-CXD1095	10 EXPANDER	
U4	SIM-74HC04	HEX INVERTER	
U5	SIM-74HC32	QUAD 2-INPUT POSI-NOR	
U6	SIT-DN8650	LOW-ACTIVE DRIVERS	
U7	SIA-412-1	OP AMP DUAL LOW DRIFT, LOW OFFSET	
U8-9	SIA-DA7545	12-BIT D/A CONVERTER WITH BUFFER	
U10	SIA-DA7533	10-BIT D/A CONVERTER	
U11	SIA-DA7545	12-BIT D/A CONVERTER WITH BUFFER	
U12	SIA-DA7524	8-BIT D/A CONVERTER WITH BUFFER	
U15	SIA-412-1	OP AMP DUAL LOW DRIFT, LOW OFFSET	
U16	SIA-TL072	OP AMP DUAL LOW NOISE	
U17-18	SIA-412-1	OP AMP DUAL LOW DRIFT, LOW OFFSET	
U19	SIA-DG201-1	QUAD ANALOG SWITCHES	
U20	SIA-412-1	OP AMP DUAL LOW DRIFT, LOW OFFSET	
U21-23	SIA-DG201-1	QUAD ANALOG SWITCHES	
U24	SIA-TL072-1	OP AMP DUAL LOW NOISE	
U25-26	SIA-OP07P	OP AMP LOW OFFSET	
U27	SIA-TL072	OP AMP DUAL LOW NOISE	
U28	SIA-TL072-1	OP AMP LOW NOISE	

R3261/3361
 RF CONT
 BLQ-015672 (4/4)

Parts No.	Advantest Stock No.	Description	Note
U29 U30 U31 U32 U33	SIA-OP07P SIA-TL072-1 SIA-OP27GD-2 SIA-412-1 SIA-TL072	OP AMP LOW OFFSET OP AMP DUAL LOW NOISE OP AMP LOW OFFSET OP AMP DUAL LOW DRIFT, LOW OFFSET OP AMP LOW NOISE	
U34-38 U37-38 U39 U40	SIM-74HC175 SIM-74HC32 SIM-74HC04 SIA-DG201	QUAD 8 FLIP-FLOPS QUAD 2-INPUT POSI-OR HEX INVERTER QUAD ANALOG SWITCHES	

R3261/3361
IF SECTION
BLQ-015668 (1/20)

Parts No:	Advantest Stock No.	Description	Note
C1	CMC-AC470PR3K	FXD DIPPED MICA 470PF ±5% 300V	
C2	CMC-AD1800PR5K	FXD DIPPED MICA 1800PF ±5% 500V	
C3	CMC-ACS80PR3K	FXD DIPPED MICA 560PF ±5% 300V	
C4	CMC-AC470PR3K	FXD DIPPED MICA 470PF ±5% 300V	
C5	CCP-BBR1U50V	FXD CHIP 0.1 μ F +80%, -20% 50V	
C6	CCP-BAR01U50V	FXD CHIP 0.01 μ F ±10PF 50V	
C7	CCP-BAP50V	FXD CHIP 8PF ±0.5PF 50V	
C8	CTM-BMBP	VAR CHIP 8PF +60%, -4% 100V	
C9	CCP-AT27PR1K	FXD CHIP 27PF ±5% 100V	
C10	CTM-BM20P	VAR CTM 20PF +50%, -4% 100V	
C11	CCP-BAR01U50V	FXD CHIP 0.01 μ F ±10% 50V	
C16	CCP-BBR1U50V	FXD CHIP 0.1 μ F +80%, -20% 50V	
C18	CCP-BAR01U50V	FXD CHIP 0.01 μ F ±10% 50V	
C19	CCP-BAP50V	FXD CHIP 8PF ±0.5PF 50V	
C20	CTM-BMBP	VAR CHIP 8PF +60%, -4% 100V	
C21	CCP-AT27PR1K	FXD CHIP 27PF ±5% 100V	
C22	CTM-BM20P	VAR CHIP 20PF +50%, -4% 100V	
C23	CCP-BAR01U50V	FXD CHIP 0.01 μ F ±10% 50V	
C29	CCP-BBR1U50V	FXD CHIP 0.1 μ F +80%, -20% 50V	
C31	CCP-BAR01U50V	FXD CHIP 0.01 μ F ±10% 50V	
C39	CCP-AX1000PR1K	FXD CHIP 1000PF ±1% 100V	
C40	CCP-BBR1U50V	FXD CHIP 0.1 μ F +80%, -20% 50V	
C42	CCP-BAR01U50V	FXD CHIP 0.01 μ F ±10% 50V	
C46	CCP-AX1000PR1K	FXD CHIP 1000PF ±1% 100V	
C47	CCP-BBR1U50V	FXD CHIP 0.1 μ F +80%, -20% 50V	
C49	CCP-BAR01U50V	FXD CHIP 0.01 μ F ±10% 50V	
C51	CCP-BBR1U50V	FXD CHIP 0.1 μ F +80%, -20% 50V	
C54	CCP-BAR01U50V	FXD CHIP 0.01 μ F ±10% 50V	
C58	CCP-BBR1U50V	FXD CHIP 0.1 μ F +80%, -20% 50V	
C60	CCP-BAR01U50V	FXD CHIP 0.01 μ F ±10% 50V	
C61	CCP-BBR1U50V	FXD CHIP 0.1 μ F +80%, -20% 50V	
C62	CCP-BAR01U50V	FXD CHIP 0.01 μ F ±10% 50V	
C63	CCP-BBR1U50V	FXD CHIP 0.1 μ F +80%, -20% 50V	
C65	CCP-BAR01U50V	FXD CHIP 0.01 μ F ±10% 50V	
C66	CCP-BBR1U50V	FXD CHIP 0.1 μ F +80%, -20% 50V	
C67	CCP-BAR01U50V	FXD CHIP 0.01 μ F ±10% 50V	
C68	CCP-BBR1U50V	FXD CHIP 0.1 μ F +80%, -20% 50V	
C72	CCP-BAR01U50V	FXD CHIP 0.01 μ F ±10% 50V	
C73	CCP-BBR1U50V	FXD CHIP 0.1 μ F +80%, -20% 50V	
C75	CCP-BAR01U50V	FXD CHIP 0.01 μ F ±10% 50V	

**R3261/3361
IF SECTION
BLQ-015668 (2/20)**

Parts No.	Advantest Stock No.	Description			Note
C76	CCP-BBR1U50V	FXD	CHIP	0.1 μ F +80%, -20% 50V	
C77	CCP-BAR01U50V	FXD	CHIP	0.01 μ F \pm 10% 50V	
C78	CCP-BBR1U50V	FXD	CHIP	0.1 μ F +80%, -20% 50V	
C82	CCP-BBR1U50V	FXD	CHIP	0.1 μ F +80%, -20% 50V	
C90	CCP-AT1R5PR1K	FXD	CHIP	1.5PF \pm 10% 100V	
C96	CCP-BBR1U50V	FXD	CHIP	0.1 μ F +80%, -20% 50V	
C98	CCP-BAR01U50V	FXD	CHIP	0.01 μ F \pm 10% 50V	
C103	CCP-BBR1U50V	FXD	CHIP	0.1 μ F +80%, -20% 50V	
C108	CCP-AX1000PR1K	FXD	CHIP	1000PF \pm 1% 100V	
C109	CCP-BBR1U50V	FXD	CHIP	0.1 μ F +80%, -20% 50V	
C111	CCP-BAR01U50V	FXD	CHIP	0.01 μ F \pm 10% 50V	
C117	CCP-AX1000PR1K	FXD	CHIP	1000PF \pm 1% 100V	
C118	CCP-BBR1U50V	FXD	CHIP	0.1 μ F +80%, -20% 50V	
C120	CCP-BAR01U50V	FXD	CHIP	0.01 μ F \pm 10% 50V	
C121	CCP-AT27PR1K	FXD	CHIP	27PF \pm 10% 100V	
C122	CTM-BM20P	VAR	20PF	+50%, -0% 100V	
C123	CCP-BAP50V	FXD	CHIP	8PF \pm 0.5PF 50V	
C124	CTM-BM6P	VAR	6PF	+50%, -0% 100V	
C125	CCP-BAR01U50V	FXD	CHIP	0.01 μ F \pm 10% 50V	
C131	CCP-BBR1U50V	FXD	CHIP	0.1 μ F +80%, -20% 50V	
C132	CCP-BAR01U50V	FXD	CHIP	0.01 μ F \pm 10% 50V	
C133	CCP-AT27PR1K	FXD	CHIP	27PF \pm 10% 100V	
C134	CTM-BM20P	VAR	20PF	+50%, -0% 100V	
C135	CCP-BAP50V	FXD	CHIP	8PF \pm 0.5PF 50V	
C136	CTM-BM6P	VAR	6PF	+50%, -0% 100V	
C137	CCP-BAR01U50V	FXD	CHIP	0.01 μ F \pm 10% 50V	
C144	CCP-AWB20PR1K	FXD	CHIP	820PF \pm 1% 100V	
C145	CCP-BAR01U50V	FXD	CHIP	0.01 μ F \pm 10% 50V	
C146	CCP-BA100P50V	FXD	CHIP	100PF \pm 10% 50V	
C147	CCP-BAR01U50V	FXD	CHIP	0.01 μ F \pm 10% 50V	
C148	CCP-AT7PR1K	FXD	CHIP	7PF \pm 10% 100V	
C150	CCP-AT1PR1K	FXD	CHIP	1PF \pm 10% 100V	
C154	CCP-AT12PR1K	FXD	CHIP	12PF \pm 10% 100V	
C155	CCP-BAR01U50V	FXD	CHIP	0.01 μ F \pm 10% 50V	
C156	CCP-BAR01U50V	FXD	CHIP	0.01 μ F \pm 10% 50V	
C157	CCP-BBR1U50V	FXD	CHIP	0.1 μ F +80%, -20% 50V	
C158	CCP-BAR01U50V	FXD	CHIP	0.01 μ F \pm 10% 50V	
C160	CCP-BBR1U50V	FXD	CHIP	0.1 μ F +80%, -20% 50V	
C162	CCP-BAR01U50V	FXD	CHIP	0.01 μ F \pm 10% 50V	
C163	CCP-AW330PR1K	FXD	CHIP	330PF \pm 1% 100V	

R3261/3361
 IF SECTION
 BLC-015688 (3/20)

Parts No.	Advantest Stock No.	Description	Note
C164	CCP-BAR01U50V	FXD CHIP 0.01 μ F \pm 10% 50V	
C165	CCP-BBR1U50V	FXD CHIP 0.1 μ F +80%, -20% 50V	
C166	CCP-BBR1U50V	FXD CHIP 0.1 μ F +80%, -20% 50V	
C167	CCP-BBR1U50V	FXD CHIP 0.1 μ F +80%, -20% 50V	
C168	CCP-BBR1U50V	FXD CHIP 0.1 μ F +80%, -20% 50V	
C170	CCP-BAR01U50V	FXD CHIP 0.01 μ F \pm 10% 50V	
C172	CCP-AW360PR1K	FXD CHIP 360PF \pm 1% 100V	
C173	CCP-BBR1U50V	FXD CHIP 0.1 μ F +80%, -20% 50V	
C174	CCP-BAR01U50V	FXD CHIP 0.01 μ F \pm 10% 50V	
C175	CCP-BBR1U50V	FXD CHIP 0.1 μ F +80%, -20% 50V	
C176	CCP-BAR01U50V	FXD CHIP 0.01 μ F \pm 10% 50V	
C178	CCP-BBR1U50V	FXD CHIP 0.1 μ F +80%, -20% 50V	
C181	CCP-AT22PR1K	FXD CHIP 22PF \pm 10% 100V	
C182	CCP-AT20PR1K	FXD CHIP 20PF \pm 10% 100V	
C184	CCP-BA15P50V	FXD CHIP 15PF \pm 5% 50V	
C185	CCP-BBR1U50V	FXD CHIP 0.1 μ F +80%, -20% 50V	
C187	CCP-AV220PR1K	FXD CHIP 220PF \pm 1% 100V	
C188	CCP-AW360PR1K	FXD CHIP 360PF \pm 1% 100V	
C190	CCP-AV220PR1K	FXD CHIP 220PF \pm 1% 100V	
C191	CFM-AHR22U100V	FXD CHIP 0.22 μ F \pm 10% 100V	
C192	CFM-ASR022U50V	FXD CHIP 0.022 μ F \pm 10% 50V	
C193	CFM-AS220P50V	FXD CHIP 2200PF \pm 10% 50V	
C194	CCP-BA1000P50V	FXD CHIP 1000PF \pm 10% 50V	
C195	CCP-BAR01U50V	FXD CHIP 0.01 μ F \pm 10% 50V	
C196	CCP-BBR1U50V	FXD CHIP 0.1 μ F +80%, -20% 50V	
C198	CCP-BAR01U50V	FXD CHIP 0.01 μ F \pm 10% 50V	
C199	CCP-BAR01U50V	FXD CHIP 0.01 μ F \pm 10% 50V	
C201	CCP-AT22PR1K	FXD CHIP 22PF \pm 10% 100V	
C202	CCP-BA8P50V	FXD CHIP 8PF \pm 0.5PF 50V	
C203	CCP-BA3P50V	FXD CHIP 3PF \pm 0.25PF 50V	
C204	CCP-BA33P50V	FXD CHIP 33PF \pm 5% 50V	
C205	CFM-AHR47U100V	FXD CHIP 0.47 μ F \pm 10% 100V	
C206	CCP-TF1U50V	FXD CHIP 1 μ F +80%, -20% 50V	
C208	CCP-BBR1U50V	FXD CHIP 0.1 μ F +80%, -20% 50V	
C213	CCP-BA1000P50V	FXD CHIP 1000PF \pm 10% 50V	
C214	CCP-BA1000P50V	FXD CHIP 1000PF \pm 10% 50V	
C215	CCP-BBR1U50V	FXD CHIP 0.1 μ F +80%, -20% 50V	
C216	CCP-TF1U50V	FXD CHIP 1 μ F +80%, -20% 50V	
C217	CCP-BAR01U50V	FXD CHIP 0.01 μ F \pm 10% 50V	
C218	CCP-TF1U50V	FXD CHIP 1 μ F +80%, -20% 50V	

R3261/3361
IF SECTION
BLQ-015688 (4/20)

Parts No.	Advantest Stock No.	Description			Note
C219	CCP-BBR1U50V	FXD	CHIP	0.1 μ F +80%, -20% 50V	
C220	CCP-BAR01U50V	FXD	CHIP	0.01 μ F \pm 10% 50V	
C221	CCP-AV100PR1K	FXD	CHIP	100PF \pm 2% 100V	
C222	CCP-BBR1U50V	FXD	CHIP	0.1 μ F +80%, -20% 50V	
C224	CCP-BAR01U50V	FXD	CHIP	0.01 μ F \pm 10% 50V	
C226	CTA-AZ8R8U16V	FXD	TA	8.8 μ F \pm 20% 16V	
C228	CCP-BBR1U50V	FXD	CHIP	0.1 μ F +80%, -20% 50V	
C230	CCK-CM47U16V-1	FXD	ELECT	47 μ F \pm 20% 16V	
C231	CCP-BBR1U50V	FXD	CHIP	0.1 μ F +80%, -20% 50V	
C261	CCP-BBR1U50V	FXD	CHIP	0.1 μ F +80%, -20% 50V	
C262	CCP-BBR1U50V	FXD	CHIP	0.1 μ F +80%, -20% 50V	
C267	CCP-BBR1U50V	FXD	CHIP	0.1 μ F +80%, -20% 50V	
C268	CCP-BBR1U50V	FXD	CHIP	0.1 μ F +80%, -20% 50V	
C280	CCP-BBR033U50V	FXD	CHIP	0.033 μ F \pm 10% 50V	
C282	CCK-CM22U25V-1	FXD	ELECT	22 μ F \pm 20% 25V	
C288	CCK-CM100U25V-1	FXD	ELECT	100 μ F \pm 20% 25V	
C292	CCK-CM22U25V-1	FXD	ELECT	22 μ F \pm 20% 25V	
C294	CCP-TF1U50V	FXD	CHIP	1 μ F +80%, -20% 50V	
C295	CCP-BBR1U50V	FXD	CHIP	0.1 μ F +80%, -20% 50V	
C298	CCP-BBR1U50V	FXD	CHIP	0.1 μ F +80%, -20% 50V	
C501	CCK-CM22U25V-1	FXD	ELECT	22 μ F \pm 20% 25V	
C507	CCP-BBR1U50V	FXD	CHIP	0.1 μ F +80%, -20% 50V	
C519	CFM-ASR033U50V	FXD	FILM	0.033 μ F \pm 10% 50V	
C520	CCP-BBR1U50V	FXD	CHIP	0.1 μ F +80%, -20% 50V	
C521	CCP-BA100P50V	FXD	CHIP	100PF \pm 5% 50V	
C522	CCP-BA1000P50V	FXD	CHIP	1000PF \pm 1% 50V	
C523	CCP-BA100P50V	FXD	CHIP	100PF \pm 5% 50V	
C525	CCP-BBR1U50V	FXD	CHIP	0.1 μ F +80%, -20% 50V	
C540	CCP-BBR1U50V	FXD	CHIP	0.1 μ F +80%, -20% 50V	
C550	CTA-AZ8R8U16V	FXD	TA	8.8 μ F \pm 20% 16V	
C551	CCP-BBR1U50V	FXD	CHIP	0.1 μ F +80%, -20% 50V	
C552	CCP-BA1000P50V	FXD	CHIP	1000PF \pm 1% 50V	
C553	CCP-BBR1U50V	FXD	CHIP	0.1 μ F +80%, -20% 50V	
C562	CFM-AS1000P50V	FXD	CHIP	1000PF \pm 1% 50V	
C564	CCP-BBR1U50V	FXD	CHIP	0.1 μ F +80%, -20% 50V	
C565	CCP-BBR1U50V	FXD	CHIP	0.1 μ F +80%, -20% 50V	
C566	CCP-BBR1U50V	FXD	CHIP	0.1 μ F +80%, -20% 50V	
C567	CCP-BBR1U50V	FXD	CHIP	0.1 μ F +80%, -20% 50V	
C568	CCP-BBR1U50V	FXD	CHIP	0.1 μ F +80%, -20% 50V	
C573	CMC-AC890PR3K	FXD	DIPPED MICA	890PF \pm 5% 300V	

R3261/3361
IF SECTION
BLQ-015668 (5/20)

Parts No.	Advantest Stock No.	Description	Note
C574	CCP-AV120PR1K	FXD CHIP 120PF $\pm 2\%$ 100V	
C575	CCP-BA1000P50V	FXD CHIP 1000PF $\pm 1\%$ 50V	
C576	CCP-BA100P50V	FXD CHIP 100PF $\pm 5\%$ 50V	
C578	CCP-BBR1U50V	FXD CHIP 0.1 μ F +80% -20% 50V	
C588	CCP-BBR1U50V	FXD CHIP 0.1 μ F +80% -20% 50V	
C590	CCP-BA1000P50V	FXD CHIP 1000PF $\pm 1\%$ 50V	
CB1	DCB-FF0871X08A-1		
D1	SDS-MA78	DIODE SI	
D22	SDS-MA78	DIODE SI	
D23	SDS-MA78	DIODE SI	
D24	SDS-1SS97	DIODE SI	
D26	SDS-MA78	DIODE SI	
D27	SDS-LD1	DIODE SI	
D29	SDS-1SS281S	DIODE SI	
D32	SDZ-W100	ZENER DIODE	
D35	SDS-1SS270	DIODE SI	
D36	SDS-MA78	DIODE SI	
D38	SDZ-W100	ZENER DIODE	
D39	SDZ-W110	ZENER DIODE	
D40	SDS-1SS101	DIODE SI	
D501	SDZ-M030	ZENER DIODE	
D502	SDS-1SS270	DIODE SI	
D506	SDS-LD1	DIODE SI	
D508	SDZ-M051	ZENER DIODE	
D509	SDS-1SS270	DIODE SI	
D511	SDZ-M082	ZENER DIODE	
D512	SDS-LD1	DIODE SI	
J1	JCS-BQ096PX01	CONNECTOR	
J3	JCF-AC001.JX01	CONNECTOR	
J6	JCF-AC001.JX01	CONNECTOR	
L1	LCL-C00554	COIL (VAR) CUSTOM DEVICE 2.2 μ H $\pm 20\%$	
L2	LCL-C00490	COIL CUSTOM DEVICE 4 μ H	
L3	LCL-C00673	COIL CUSTOM DEVICE	
L4	LCL-C00490	COIL CUSTOM DEVICE	
L5	LCL-C00124	TOROIDAL CORE	
L8	LCL-E00890	COIL CHIP 220 μ H $\pm 10\%$	
L7	LCL-C00010	COIL CUSTOM DEVICE	
L8	LCL-C00672	COIL CUSTOM DEVICE 44 μ H 27PF	
L9	LCL-C00010	COIL 180 μ H $\pm 10\%$	
L10	LCL-C00672	COIL CUSTOM DEVICE 44 μ H 27PF	

R3261/3361
 IF SECTION
 BLQ-015668 (6/20)

Parts No.	Advantest Stock No.	Description	Note
L12	LCL-C00549	COIL (VAR) CUSTOM DEVICE 2.2 μ H \pm 10%	
L14	LCL-C00549	COIL (VAR) CUSTOM DEVICE 2.2 μ H \pm 10%	
L15	LCL-E00980	COIL CHIP 220 μ H \pm 10%	
L21	LCL-C00549	COIL (VAR) CUSTOM DEVICE 2.2 μ H \pm 10%	
L22	LCL-E00980	COIL CHIP 220 μ H \pm 10%	
L23	LCL-E00980	COIL CHIP 220 μ H \pm 10%	
L24	LCL-C00549	COIL (VAR) CUSTOM DEVICE 2.2 μ H \pm 10%	
L25	LCL-C00010	COIL 180 μ H \pm 10%	
L26	LCL-C00672	CUSTOM DEVICE 44 μ H 27PF	
L27	LCL-E00980	COIL CHIP 220 μ H \pm 10%	
L28	LCL-C00010	COIL 180 μ H \pm 10%	
L29	LCL-C00672	CUSTOM DEVICE 44 μ H 27PF	
L30	LCL-C00654	COIL (VAR) CUSTOM DEVICE 2.2 μ H \pm 20%	
L31	LCL-E00981	COIL CHIP 5.6 μ H \pm 20%	
L32	LCL-E00980	COIL CHIP 220 μ H \pm 10%	
L41	LCL-T00084A	TOROIDAL CORE	
L47	LCL-E00980	COIL CHIP 5.6 μ H \pm 20%	
L48	LCL-E01122-1	COIL CHIP 220 μ H \pm 10%	
L501	LCL-T00084A	COIL CUSTOM DEVIC	
P1	DMY-000834-1	DELAY LINE	
P11	DMY-000834-1	DELAY LINE	
P14	DMY-000834-1	DELAY LINE	
P20	DMY-000834-1	DELAY LINE	
P31	DMY-000834-1	DELAY LINE	
P34	DMY-000834-1	DELAY LINE	
P40	DMY-000834-1	DELAY LINE	
P51	DMY-000834-1	DELAY LINE	
P54	DMY-000834-1	DELAY LINE	
P60	DMY-000834-1	DELAY LINE	
Q1	STN-2SC1623	TRANSISTOR NPN	
Q10	STT-XN6113	TRANSISTOR DUAL	
Q16	STN-2SC1623	TRANSISTOR NPN	
Q25	STP-2SA812	TRANSISTOR PNP	
Q27	STN-2SC1623	TRANSISTOR NPN	
Q33	SFN-2SK30-1	FET N-JUNCTION	
Q34	STN-2SC1623	TRANSISTOR NPN	
Q37	STP-2SA812	TRANSISTOR PNP	
Q38	STN-2SC1623	TRANSISTOR NPN	
Q44	SFN-2SK30-1	FET N-JUNCTION	
Q45	SIA-33485	TRANSISTOR TRANSISTOR ARRAY	

R3261/3361
 IF SECTION
 BLO-015668 (7/20)

Parts No.	Advantest Stock No.	Description	Note
Q47	STN-25C1623	TRANSISTOR NPN	
Q49	STP-25A812	TRANSISTOR PNP	
Q50	STN-25C1623	TRANSISTOR NPN	
Q52	SFM-8ST215S	FET MOS	
Q501	STN-25C1623	TRANSISTOR NPN	
Q502	STP-25A812	TRANSISTOR NPN	
Q503	SFN-25K113-18	FET N-JUNCTION	
Q504	SFN-25K113-18	FET N-JUNCTION	
Q505	SFM-8ST215S	FET MOS	
Q506	SFN-2N4393-18	FET N-JUNCTION	
R1	RCP-AN82	FXD CHIP 82 Ω \pm 5% 1/10W	
R2	RCP-AN56	FXD CHIP 56 Ω \pm 5% 1/10W	
R3	RCP-AN82K	FXD CHIP 82k Ω \pm 5% 1/10W	
R4	RCP-AN22	FXD CHIP 22 Ω \pm 5% 1/10W	
R5	RVR-DF100	VAR 100 Ω \pm 20% 1/2W	
R6	RCP-AN470	FXD CHIP 470 Ω \pm 5% 1/10W	
R7	RCP-AN1K	FXD CHIP 1k Ω \pm 5% 1/10W	
R9	RCP-AN100	FXD CHIP 100 Ω \pm 5% 1/10W	
R10	RCP-AN15	FXD CHIP 15 Ω \pm 5% 1/10W	
R11	RCP-AN33	FXD CHIP 33 Ω \pm 5% 1/10W	
R12	RCP-AN22K	FXD CHIP 22k Ω \pm 5% 1/10W	
R13	RCP-AN1K	FXD CHIP 1k Ω \pm 5% 1/10W	
R14	RCP-AN4R7K	FXD CHIP 4.7k Ω \pm 5% 1/10W	
R15	RCP-AN100	FXD CHIP 100 Ω \pm 5% 1/10W	
R16	RCP-AN81	FXD CHIP 81 Ω \pm 5% 1/10W	
R17	RCP-AN270	FXD CHIP 270 Ω \pm 5% 1/10W	
R18	RCP-AN360	FXD CHIP 360 Ω \pm 5% 1/10W	
R19	RCP-AN820	FXD CHIP 820 Ω \pm 5% 1/10W	
R20	RCP-AN3R8K	FXD CHIP 3.8k Ω \pm 5% 1/10W	
R21	RCP-AN560	FXD CHIP 560 Ω \pm 5% 1/10W	
R22	RCP-AN2R2K	FXD CHIP 2.2k Ω \pm 5% 1/10W	
R27	RCP-AN18K	FXD CHIP 18k Ω \pm 5% 1/10W	
R28	RCP-AN15	FXD 15k Ω \pm 5% 1/10W	
R29	RVR-DF100	VAR 100 Ω \pm 20% 1/2W	
R30	RCP-AN22K	FXD CHIP 22k Ω \pm 5% 1/10W	
R31	RCP-AN4R7K	FXD CHIP 4.7k Ω \pm 5% 1/10W	
R32	RCP-AN1K	FXD CHIP 1k Ω \pm 5% 1/10W	
R33	RCP-AN560	FXD CHIP 560 Ω \pm 5% 1/10W	
R34	RCP-AN100	FXD CHIP 100 Ω \pm 5% 1/10W	
R35	RCP-AN81	FXD CHIP 81 Ω \pm 5% 1/10W	

R3261/3361
 IF SECTION
 BLQ-015668 (8/20)

Parts No.	Advantest Stock No.	Description					Note
R36	RCP-AN270	FXD	CHIP	270n	±5%	1/10W	
R37	RCP-AN360	FXD	CHIP	360n	±5%	1/10W	
R38	RCP-AN820	FXD	CHIP	820n	±5%	1/10W	
R39	RCP-AN3R9K	FXD	CHIP	3.9kΩ	±5%	1/10W	
R40	RCP-AN2R2K	FXD	CHIP	2.2kΩ	±5%	1/10W	
R45	RCP-AN18K	FXD	CHIP	18kΩ	±5%	1/10W	
R46	RCP-AN470	FXD	CHIP	470n	±5%	1/10W	
R47	RVR-DF1K	VAR		1kΩ	±20%	1/2W	
R48	RCP-AN330	FXD	CHIP	330n	±5%	1/10W	
R49	RCP-AN2R2K	FXD	CHIP	2.2kΩ	±5%	1/10W	
R51	RCP-AN100	FXD	CHIP	100n	±5%	1/10W	
R52	RCP-AN10K	FXD	CHIP	10kΩ	±5%	1/10W	
R53	RCP-AN100	FXD	CHIP	100n	±5%	1/10W	
R54	RCP-AN2R2K	FXD	CHIP	2.2kΩ	±5%	1/10W	
R58	RCP-AN8R2K	FXD	CHIP	8.2kΩ	±5%	1/10W	
R59	RCP-AN3R3K	FXD	CHIP	3.3kΩ	±5%	1/10W	
R60	RCP-AN750	FXD	CHIP	750n	±5%	1/10W	
R61	RCP-AN220	FXD	CHIP	220n	±5%	1/10W	
R62	RCP-AN56	FXD	CHIP	56n	±5%	1/10W	
R63	RCP-AN390	FXD	CHIP	390n	±5%	1/10W	
R64	DSP-000017	THERMISTOR (SPECIAL PART)					
R65	RCP-AN470	FXD	CHIP	470n	±5%	1/10W	
R66	RCP-AN100	FXD	CHIP	100n	±5%	1/10W	
R67	RCP-AN2R2K	FXD	CHIP	2.2kΩ	±5%	1/10W	
R71	RCP-AN8R2K	FXD	CHIP	8.2kΩ	±5%	1/10W	
R72	RCP-AN3R3K	FXD	CHIP	3.3kΩ	±5%	1/10W	
R73	RCP-AN750	FXD	CHIP	750n	±5%	1/10W	
R74	RCP-AN220	FXD	CHIP	220n	±5%	1/10W	
R75	RCP-AN56	FXD	CHIP	56n	±5%	1/10W	
R76	RCP-AN560	FXD	CHIP	560n	±5%	1/10W	
R77	RVR-DF500	VAR		500Ω	±20%	1/2W	
R78	RCP-AN100	FXD	CHIP	100n	±5%	1/10W	
R79	RCP-AN150	FXD	CHIP	150n	±5%	1/10W	
R80	RCP-AN22	FXD	CHIP	22n	±5%	1/10W	
R81	RCP-AN470	FXD	CHIP	470n	±5%	1/10W	
R82	RCP-AN2R2K	FXD	CHIP	2.2kΩ	±5%	1/10W	
R86	RCP-AN24	FXD	CHIP	24n	±5%	1/10W	
R87	RVR-DF50	VAR		50Ω	±20%	1/2W	
R88	RCP-AN3K	FXD	CHIP	3kΩ	±5%	1/10W	
R89	RCP-AN2R2K	FXD	CHIP	2.2kΩ	±5%	1/10W	

R3261/3361
IF SECTION
BLQ-015668 (9/20)

Parts No.	Advantest Stock No.	Description					Note
R100	RCP-AN2K	FXD	CHIP	2k Ω	$\pm 5\%$	1/10W	
R101	RCP-AN1K	FXD	CHIP	1k Ω	$\pm 5\%$	1/10W	
R102	RCP-AN510	FXD	CHIP	510 Ω	$\pm 5\%$	1/10W	
R103	RCP-AN270	FXD	CHIP	270 Ω	$\pm 5\%$	1/10W	
R104	RCP-AN3R3K	FXD	CHIP	3.3k Ω	$\pm 5\%$	1/10W	
R105	RCP-AN2R2K	FXD	CHIP	2.2k Ω	$\pm 5\%$	1/10W	
R109	RCP-AN22	FXD	CHIP	22 Ω	$\pm 5\%$	1/10W	
R110	RVR-DF50	VAR		50 Ω	$\pm 20\%$	1/2W	
R111	RVR-DF200	VAR		200 Ω	$\pm 20\%$	1/2W	
R112	RCP-AN3K	FXD	CHIP	3k Ω	$\pm 5\%$	1/10W	
R113	RCP-AN2R2K	FXD	CHIP	2.2k Ω	$\pm 5\%$	1/10W	
R115	RCP-AN470	FXD	CHIP	470 Ω	$\pm 5\%$	1/10W	
R116	RCP-AN2R2K	FXD	CHIP	2.2k Ω	$\pm 5\%$	1/10W	
R118	RCP-AN10K	FXD	CHIP	10k Ω	$\pm 5\%$	1/10W	
R120	RCP-AN2R7K	FXD	CHIP	2.7k Ω	$\pm 5\%$	1/10W	
R121	RCP-AN430	FXD	CHIP	430 Ω	$\pm 5\%$	1/10W	
R122	RCP-AN2R2K	FXD	CHIP	2.2k Ω	$\pm 5\%$	1/10W	
R123	RCP-AN220	FXD	CHIP	220 Ω	$\pm 5\%$	1/10W	
R124	RCP-AN2R2K	FXD	CHIP	2.2k Ω	$\pm 5\%$	1/10W	
R125	RCP-AN10K	FXD	CHIP	10k Ω	$\pm 5\%$	1/10W	
R127	RCP-AN2R2K	FXD	CHIP	2.2k Ω	$\pm 5\%$	1/10W	
R128	RCP-AN180	FXD	CHIP	180 Ω	$\pm 5\%$	1/10W	
R129	RCP-AN1R3K	FXD	CHIP	1.3k Ω	$\pm 5\%$	1/10W	
R130	RCP-AN270	FXD	CHIP	270 Ω	$\pm 5\%$	1/10W	
R131	RCP-AN2R2K	FXD	CHIP	2.2k Ω	$\pm 5\%$	1/10W	
R132	RCP-AN10K	FXD	CHIP	10k Ω	$\pm 5\%$	1/10W	
R134	RCP-AN2R7K	FXD	CHIP	2.7k Ω	$\pm 5\%$	1/10W	
R135	RCP-AN150	FXD	CHIP	150 Ω	$\pm 5\%$	1/10W	
R136	RCP-AN1R1K	FXD	CHIP	1.1k Ω	$\pm 5\%$	1/10W	
R137	RCP-AN510	FXD	CHIP	510 Ω	$\pm 5\%$	1/10W	
R138	RCP-AN2R2K	FXD	CHIP	2.2k Ω	$\pm 5\%$	1/10W	
R139	RCP-AN10K	FXD	CHIP	10k Ω	$\pm 5\%$	1/10W	
R141	RCP-AN2R7K	FXD	CHIP	2.7k Ω	$\pm 5\%$	1/10W	
R142	RCP-AN100	FXD	CHIP	100 Ω	$\pm 5\%$	1/10W	
R143	RCP-AN180	FXD	CHIP	180 Ω	$\pm 5\%$	1/10W	
R144	RCP-AN560	FXD	CHIP	560 Ω	$\pm 5\%$	1/10W	
R145	RCP-AN2R2K	FXD	CHIP	2.2k Ω	$\pm 5\%$	1/10W	
R146	RCP-AN22	FXD	CHIP	22 Ω	$\pm 5\%$	1/10W	
R147	RCP-AN470	FXD	CHIP	470 Ω	$\pm 5\%$	1/10W	
R148	RCP-AN1K	FXD	CHIP	1k Ω	$\pm 5\%$	1/10W	

R3261/3361
 IF SECTION
 BLQ-01568 (10/20)

Parts No.	Advantest Stock No.	Description			Note
R149	RVR-DF50	VAR	500	±20%	1/2W
R150	RCP-AN3K	FXD CHIP	3k0	±5%	1/10W
R151	RCP-AJ2R2K	FXD CHIP	2.2k0	±5%	1/10W
R152	RCP-AN22	FXD CHIP	220	±5%	1/10W
R153	RCP-AN470	FXD CHIP	4700	±5%	1/10W
R154	RCP-AN2R2K	FXD CHIP	2.2k0	±5%	1/10W
R155	RCP-AN2R2K	FXD CHIP	2.2k0	±5%	1/10W
R156	RCP-AN1K	FXD CHIP	1k0	±5%	1/10W
R157	RCP-AN22	FXD CHIP	220	±5%	1/10W
R158	RCP-AN470	FXD CHIP	4700	±5%	1/10W
R159	RVR-DF50	VAR	500	±20%	1/2W
R160	RCP-AN2R2K	FXD CHIP	2.2k0	±5%	1/10W
R161	RCP-AN1K	FXD CHIP	1k0	±5%	1/10W
R164	RAY-TL47K6	FXD RA	47k0 × 6	±5%	1/8W
R166	RCP-AN4R7K	FXD CHIP	4.7k0	±5%	1/10W
R168	RAY-TL47K4	FXD RA	47k0 × 4	±5%	1/8W
R170	RCP-AN380	FXD CHIP	3800	±5%	1/10W
R171	RCP-AN380	FXD CHIP	3800	±5%	1/10W
R172	RCP-AN2R2K	FXD CHIP	2.2k0	±5%	1/10W
R180	RCP-AN10K	FXD CHIP	10k0	±5%	1/10W
R181	RCP-AN100	FXD CHIP	1000	±5%	1/10W
R182	RCP-AN2R2K	FXD CHIP	2.2k0	±5%	1/10W
R187	RCP-AN8R2K	FXD CHIP	8.2k0	±5%	1/10W
R188	RCP-AN3R3K	FXD CHIP	3.3k0	±5%	1/10W
R189	RCP-AN1R2K	FXD CHIP	1.2k0	±5%	1/10W
R190	RCP-AN680	FXD CHIP	6800	±5%	1/10W
R191	RCP-AN220	FXD CHIP	2200	±5%	1/10W
R182	RCP-AN56	FXD CHIP	560	±5%	1/10W
R193	RCP-AN560	FXD CHIP	5600	±5%	1/10W
R194	RVR-DF500	VAR	5000	±20%	1/2W
R195	RCP-AN100	FXD CHIP	1000	±5%	1/10W
R196	RCP-AN2R2K	FXD CHIP	2.2k0	±5%	1/10W
R201	RCP-AN8R2K	FXD CHIP	8.2k0	±5%	1/10W
R202	RCP-AN3R3K	FXD CHIP	3.3k0	±5%	1/10W
R203	RCP-AN1R2K	FXD CHIP	1.2k0	±5%	1/10W
R204	RCP-AN680	FXD CHIP	6800	±5%	1/10W
R205	RCP-AN220	FXD CHIP	2200	±5%	1/10W
R206	RCP-AN56	FXD CHIP	560	±5%	1/10W
R207	RCP-AN470	FXD CHIP	4700	±5%	1/10W
R208	DSP-00017	THERMISTOR	CUSTOM DEVICE		

R3261/3361
IF SECTION
BLO-015668 (11/20)

Parts No.	Advantest Stock No.	Description	Note
R209	RCP-AN100	FXD CHIP 100 Ω \pm 5% 1/10W	
R211	RCP-AN15	FXD CHIP 15 Ω \pm 5% 1/10W	
R212	RCP-AN33	FXD CHIP 33 Ω \pm 5% 1/10W	
R213	RCP-AN150	FXD CHIP 150 Ω \pm 5% 1/10W	
R214	RCP-AN4R7K	FXD CHIP 4.7k Ω \pm 5% 1/10W	
R215	RCP-AN22K	FXD CHIP 22k Ω \pm 5% 1/10W	
R216	RCP-AN1K	FXD CHIP 1k Ω \pm 5% 1/10W	
R217	RCP-AN560	FXD CHIP 560 Ω \pm 5% 1/10W	
R218	RCP-AN82	FXD CHIP 82 Ω \pm 5% 1/10W	
R219	RCP-AN270	FXD CHIP 270 Ω \pm 5% 1/10W	
R220	RCP-AN360	FXD CHIP 360 Ω \pm 5% 1/10W	
R221	RCP-AN820	FXD CHIP 820 Ω \pm 5% 1/10W	
R222	RCP-AN3R3K	FXD CHIP 3.3k Ω \pm 5% 1/10W	
R223	RCP-AN18K	FXD CHIP 18k Ω \pm 5% 1/10W	
R224	RCP-AN2R2K	FXD CHIP 2.2k Ω \pm 5% 1/10W	
R230	RCP-AN180K	FXD CHIP 180k Ω \pm 5% 1/10W	
R231	RCP-AJ15	FXD CHIP 15 Ω \pm 5% 1/10W	
R232	RVR-DF100	VAR 100 Ω \pm 20% 1/2W	
R233	RCP-AN150	FXD CHIP 150 Ω \pm 5% 1/10W	
R234	RCP-AN4R7K	FXD CHIP 4.7k Ω \pm 5% 1/10W	
R235	RCP-AN22K	FXD CHIP 22k Ω \pm 5% 1/10W	
R236	RCP-AN1K	FXD CHIP 1k Ω \pm 5% 1/10W	
R237	RCP-AN560	FXD CHIP 560 Ω \pm 5% 1/10W	
R238	RCP-AN82	FXD CHIP 82 Ω \pm 5% 1/10W	
R239	RCP-AN270	FXD CHIP 270 Ω \pm 5% 1/10W	
R240	RCP-AN360	FXD CHIP 360 Ω \pm 5% 1/10W	
R241	RCP-AN820	FXD CHIP 820 Ω \pm 5% 1/10W	
R242	RCP-AN3R3K	FXD CHIP 3.3k Ω \pm 5% 1/10W	
R243	RCP-AN18K	FXD CHIP 18k Ω \pm 5% 1/10W	
R244	RCP-AN2R2K	FXD CHIP 2.2k Ω \pm 5% 1/10W	
R250	RCP-AN180K	FXD CHIP 180k Ω \pm 5% 1/10W	
R251	RCP-AN560	FXD CHIP 560 Ω \pm 5% 1/10W	
R252	RVR-DF1K	VAR 1k Ω \pm 20% 1/2W	
R253	RCP-AN470	FXD CHIP 470 Ω \pm 5% 1/10W	
R254	RCP-AN680	FXD CHIP 680 Ω \pm 5% 1/10W	
R255	RCP-AN220	FXD CHIP 220 Ω \pm 5% 1/10W	
R256	RCP-AN10K	FXD CHIP 10k Ω \pm 5% 1/10W	
R257	RCP-AN1K	FXD CHIP 1k Ω \pm 5% 1/10W	
R258	RCP-AN1K	FXD CHIP 1k Ω \pm 5% 1/10W	
R261	RCP-AN18	FXD CHIP 18 Ω \pm 5% 1/10W	

R3261/3361
IF SECTION
BLQ-015668 (12/20)

Parts No.	Advantest Stock No.	Description					Note
R265	RCP-AN820	FXD	CHIP	820n	±5%	1/10W	
R266	RCP-AN15K	FXD	CHIP	15kn	±5%	1/10W	
R268	RCP-AN1R5K	FXD	CHIP	1.5kn	±5%	1/10W	
R269	RCP-AN100	FXD	CHIP	100n	±5%	1/10W	
R270	RCP-AN82	FXD	CHIP	82n	±5%	1/10W	
R271	RCP-AN4R7K	FXD	CHIP	4.7kn	±5%	1/10W	
R272	RCP-AN18	FXD	CHIP	18n	±5%	1/10W	
R277	RCP-AN10K	FXD	CHIP	10kn	±5%	1/10W	
R278	RCP-AN5R6K	FXD	CHIP	5.6kn	±5%	1/10W	
R279	RCP-AN18	FXD	CHIP	18n	±5%	1/10W	
R280	RCP-AN3R5K	FXD	CHIP	3.9kn	±5%	1/10W	
R281	RCP-AN580	FXD	CHIP	580n	±5%	1/10W	
R282	RCP-AN110	FXD	CHIP	110n	±5%	1/10W	
R283	RCP-AN10	FXD	CHIP	10n	±5%	1/10W	
R284	RCP-AN15K	FXD	CHIP	15kn	±5%	1/10W	
R286	RCP-AN2R2K	FXD	CHIP	2.2kn	±5%	1/10W	
R287	RCP-AN10	FXD	CHIP	10n	±5%	1/10W	
R288	RCP-AN150	FXD	CHIP	150n	±5%	1/10W	
R289	RCP-AN51	FXD	CHIP	51n	±5%	1/10W	
R290	RCP-AN2R2K	FXD	CHIP	2.2kn	±5%	1/10W	
R291	RCP-AN15K	FXD	CHIP	15kn	±5%	1/10W	
R293	RCP-AN18K	FXD	CHIP	18kn	±5%	1/10W	
R294	RCP-AN15K	FXD	CHIP	15kn	±5%	1/10W	
R295	RCP-AN1K	FXD	CHIP	1kn	±5%	1/10W	
R297	RCP-AN820	FXD	CHIP	820n	±5%	1/10W	
R298	RVR-DF100	VAR		100n	±20%	1/2W	
R299	RCP-AN180	FXD	CHIP	180n	±5%	1/10W	
R300	RCP-AN82	FXD	CHIP	82n	±5%	1/10W	
R301	RVR-DF50	VAR		50n	±20%	1/2W	
R302	RCP-AN1K	FXD	CHIP	1kn	±5%	1/10W	
R303	RCP-AN390	FXD	CHIP	390n	±5%	1/10W	
R304	RCP-AN15K	FXD	CHIP	15kn	±5%	1/10W	
R305	RCP-AN390	FXD	CHIP	390n	±5%	1/10W	
R306	RCP-AN33K	FXD	CHIP	33kn	±5%	1/10W	
R307	RCP-AN47K	FXD	CHIP	47kn	±5%	1/10W	
R309	RCP-AN10	FXD	CHIP	10n	±5%	1/10W	
R310	RCP-AN5R6K	FXD	CHIP	5.6kn	±5%	1/10W	
R312	RCP-AN10K	FXD	CHIP	10kn	±5%	1/10W	
R313	RCP-AN22	FXD	CHIP	22n	±5%	1/10W	
R314	RCP-AN1R2K	FXD	CHIP	1.2kn	±5%	1/10W	

R3261/3361
 IF SECTION
 BLQ-015668 (13/20)

Parts No:	Advantest Stock No.	Description	Note
R315	RCP-AN470	FXD CHIP 470k Ω \pm 5% 1/10W	
R316	RCP-AN6R8K	FXD CHIP 6.8k Ω \pm 5% 1/10W	
R317	RCP-AN22K	FXD CHIP 22k Ω \pm 5% 1/10W	
R318	RCP-AN1R2K	FXD CHIP 1.2k Ω \pm 5% 1/10W	
R320	RCP-AN6R8K	FXD CHIP 6.8k Ω \pm 5% 1/10W	
R321	RCP-AN3R3K	FXD CHIP 3.3k Ω \pm 5% 1/10W	
R322	RCP-AN10K	FXD CHIP 10k Ω \pm 5% 1/10W	
R323	RCP-AN1K	FXD CHIP 1k Ω \pm 5% 1/10W	
R324	RCP-AN15K	FXD CHIP 15k Ω \pm 5% 1/10W	
R325	RCP-AN180K	FXD CHIP 180k Ω \pm 5% 1/10W	
R326	RVR-CB200K	VAR 200k Ω \pm 20% 1/2W	
R327	RCP-AN1K	FXD CHIP 1k Ω \pm 5% 1/10W	
R334	RCP-AN680K	FXD CHIP 680k Ω \pm 5% 1/10W	
R335	RCP-AN100K	FXD CHIP 100k Ω \pm 5% 1/10W	
R336	RCP-AN680	FXD CHIP 680 Ω \pm 5% 1/10W	
R337	RAY-TL22K4	FXD RA 22k Ω x 4 \pm 5% 1/8W	
R338	RAY-TK10K4	FXD RA 10k Ω x 4 \pm 2% 1/8W	
R339	RCP-AN180	FXD CHIP 180 Ω \pm 5% 1/10W	
R343	RCP-AN10K	FXD CHIP 10k Ω \pm 5% 1/10W	
R344	RCP-AN1K	FXD CHIP 1k Ω \pm 5% 1/10W	
R346	RCP-AN4R7K	FXD CHIP 4.7k Ω \pm 5% 1/10W	
R347	RVR-DF5K	VAR 5k Ω \pm 20% 1/2W	
R348	RCP-AN1R2K	FXD CHIP 1.2k Ω \pm 5% 1/10W	
R349	RCP-AN68K	FXD CHIP 68k Ω \pm 5% 1/10W	
R350	RCP-AN2R2K	FXD CHIP 2.2k Ω \pm 5% 1/10W	
R351	RCP-AN5R6K	FXD CHIP 5.6k Ω \pm 5% 1/10W	
R352	RCP-AN10K	FXD CHIP 10k Ω \pm 5% 1/10W	
R354	RCP-AN1R5K	FXD CHIP 1.5k Ω \pm 5% 1/10W	
R355	RCP-AN10K	FXD CHIP 10k Ω \pm 5% 1/10W	
R356	RCP-AN1R5K	FXD CHIP 1.5k Ω \pm 5% 1/10W	
R357	RAY-TL22K4	FXD RA 22k Ω x 4 \pm 5% 1/8W	
R358	RAY-TK10K4	FXD RA 10k Ω x 4 \pm 2% 1/8W	
R359	RCP-AN100K	FXD CHIP 100k Ω \pm 5% 1/10W	
R360	RVR-DF2K	VAR 2k Ω \pm 20% 1/2W	
R361	RCP-AN36K	FXD CHIP 36k Ω \pm 5% 1/10W	
R362	RCP-AN10K	FXD CHIP 10k Ω \pm 5% 1/10W	
R363	RCP-AN1R2K	FXD CHIP 1.2k Ω \pm 5% 1/10W	
R364	RCP-AN2R4K	FXD CHIP 2.4k Ω \pm 5% 1/10W	
R366	RCP-AN10K	FXD CHIP 10k Ω \pm 5% 1/10W	
R368	RCP-AN1K	FXD CHIP 1k Ω \pm 5% 1/10W	

R3261/3361
 IF SECTION
 BLQ-015668 (14/20)

Parts No.	Advantest Stock No.	Description					Note
R369	RCP-AN100K	FXD	CHIP	100k Ω	$\pm 5\%$	1/10W	
R370	RVR-DF5K	VAR		5k Ω	$\pm 20\%$	1/2W	
R371	RCP-AN36K	FXD	CHIP	36k Ω	$\pm 5\%$	1/10W	
R372	RCP-AN1R2K	FXD	CHIP	1.2k Ω	$\pm 5\%$	1/10W	
R373	RCP-AN3R6K	FXD	CHIP	3.6k Ω	$\pm 5\%$	1/10W	
R374	RCP-AN15K	FXD	CHIP	15k Ω	$\pm 5\%$	1/10W	
R375	RCP-AN150	FXD	CHIP	150 Ω	$\pm 5\%$	1/10W	
R376	RCP-AN100K	FXD	CHIP	100k Ω	$\pm 5\%$	1/10W	
R378	RCP-AN680	FXD	CHIP	680 Ω	$\pm 5\%$	1/10W	
R379	RCP-AN470K	FXD	CHIP	470k Ω	$\pm 5\%$	1/10W	
R380	RCP-AN1M	FXD	CHIP	1M Ω	$\pm 5\%$	1/10W	
R382	RCP-AN680	FXD	CHIP	680 Ω	$\pm 5\%$	1/10W	
R383	RCP-AN91K	FXD	CHIP	91k Ω	$\pm 5\%$	1/10W	
R384	RCP-AN1R8K	FXD	CHIP	1.8k Ω	$\pm 5\%$	1/10W	
R387	RCP-AN150K	FXD	CHIP	150k Ω	$\pm 5\%$	1/10W	
R388	RCP-AN270K	FXD	CHIP	270k Ω	$\pm 5\%$	1/10W	
R390	RCP-AN150K	FXD	CHIP	150k Ω	$\pm 5\%$	1/10W	
R391	RCP-AN3R6K	FXD	CHIP	3.6k Ω	$\pm 5\%$	1/10W	
R392	RCP-AN100K	FXD	CHIP	100k Ω	$\pm 5\%$	1/10W	
R393	RCP-AN180	FXD	CHIP	180 Ω	$\pm 5\%$	1/10W	
R394	RCP-AN180	FXD	CHIP	180 Ω	$\pm 5\%$	1/10W	
R395	RCP-AN100K	FXD	CHIP	100k Ω	$\pm 5\%$	1/10W	
R396	RVR-DF20K	VAR		20k Ω	$\pm 20\%$	1/2W	
R398	RCP-AN36K	FXD	CHIP	36k Ω	$\pm 5\%$	1/10W	
R399	RCP-AN10K	FXD	CHIP	10k Ω	$\pm 5\%$	1/10W	
R400	RVR-DF1K	VAR		1k Ω	$\pm 20\%$	1/2W	
R401	RCP-AN2R7K	FXD	CHIP	2.7k Ω	$\pm 5\%$	1/10W	
R402	REE-AR510	FXD	THERMAL	510 Ω	(3300 PPM/C)		
R403	RCP-AN3R6K	FXD	CHIP	3.6k Ω	$\pm 5\%$	1/10W	
R404	RCP-AN10K	FXD	CHIP	10k Ω	$\pm 5\%$	1/10W	
R405	RCP-AN22K	FXD	CHIP	22k Ω	$\pm 5\%$	1/10W	
R406	RCP-AN330	FXD	CHIP	330 Ω	$\pm 5\%$	1/10W	
R407	RCP-AN1M	FXD	CHIP	1M Ω	$\pm 5\%$	1/10W	
R408	RCP-AN10K	FXD	CHIP	10k Ω	$\pm 5\%$	1/10W	
R411	RCP-AN33K	FXD	CHIP	33k Ω	$\pm 5\%$	1/10W	
R413	RCP-AN1K	FXD	CHIP	1k Ω	$\pm 5\%$	1/10W	
R414	RVR-DF1K	VAR		1k Ω	$\pm 20\%$	1/2W	
R416	RCP-AN4R7K	FXD	CHIP	4.7k Ω	$\pm 5\%$	1/10W	
R417	RCP-AN22K	FXD	CHIP	22k Ω	$\pm 5\%$	1/10W	
R418	RCP-AN10K	FXD	CHIP	10k Ω	$\pm 5\%$	1/10W	

**R3261/3361
IF SECTION
BLO-015668 (15/20)**

Parts No.	Advantest Stock No.	Description	Note
R419	RCP-AN510	FXD CHIP 510Ω ±5% 1/10W	
R420	RCP-AN1R5K	FXD CHIP 1.5kΩ ±5% 1/10W	
R421	RCP-AN3K	FXD CHIP 3kΩ ±5% 1/10W	
R422	RCP-AN1R5K	FXD CHIP 1.5kΩ ±5% 1/10W	
R423	RCP-AN10K	FXD CHIP 10kΩ ±5% 1/10W	
R424	RCP-AN10K	FXD CHIP 10kΩ ±5% 1/10W	
R428	RCP-AN1R5K	FXD CHIP 1.5kΩ ±5% 1/10W	
R429	RCP-AN2R7K	FXD CHIP 2.7kΩ ±5% 1/10W	
R430	RCP-AN5R6K	FXD CHIP 5.6kΩ ±5% 1/10W	
R431	RCP-AN100K	FXD CHIP 100kΩ ±5% 1/10W	
R432	RCP-AN270K	FXD CHIP 270kΩ ±5% 1/10W	
R433	RCP-AN1R5K	FXD CHIP 1.5kΩ ±5% 1/10W	
R434	RCP-AN2K	FXD CHIP 2kΩ ±5% 1/10W	
R436	RCP-AN10K	FXD CHIP 10kΩ ±5% 1/10W	
R438	RAY-TL22K8	FXD RA 22kΩ × 8 ±5% 1/8W	
R439	RCP-AN4R7K	FXD CHIP 4.7kΩ ±5% 1/10W	
R440	RCP-AN1R5K	FXD CHIP 1.5kΩ ±5% 1/10W	
R441	RCP-AN1K	FXD CHIP 1kΩ ±5% 1/10W	
R442	RCP-AN1R5K	FXD CHIP 1.5kΩ ±5% 1/10W	
R443	RCP-AN1K	FXD CHIP 1kΩ ±5% 1/10W	
R444	RCP-AN4R7K	FXD CHIP 4.7kΩ ±5% 1/10W	
R445	RCP-AN1R5K	FXD CHIP 1.5kΩ ±5% 1/10W	
R447	RCP-AN1R2K	FXD CHIP 1.2kΩ ±5% 1/10W	
R448	RCP-AN470	FXD CHIP 470Ω ±5% 1/10W	
R449	RCP-AN270	FXD CHIP 270Ω ±5% 1/10W	
R450	RCP-AN56	FXD CHIP 56Ω ±5% 1/10W	
R451	RCP-AN100K	FXD CHIP 100kΩ ±5% 1/10W	
R452	RCP-AN150	FXD CHIP 150Ω ±5% 1/10W	
R453	RCP-AN2R2K	FXD CHIP 2.2kΩ ±5% 1/10W	
R455	RCP-AN1R5K	FXD CHIP 1.5kΩ ±5% 1/10W	
R456	RCP-AN2R4K	FXD CHIP 2.4kΩ ±5% 1/10W	
R461	RCP-AN22K	FXD CHIP 22kΩ ±5% 1/10W	
R463	RCP-AN1K	FXD CHIP 1kΩ ±5% 1/10W	
R464	RCP-AN100K	FXD CHIP 100kΩ ±5% 1/10W	
R465	RVR-DF100K	VAR 100kΩ ±20% 1/2W	
R466	RCP-AN330	FXD CHIP 330Ω ±5% 1/10W	
R467	RVR-DF1K	VAR 1kΩ ±20% 1/2W	
R468	RCP-AN3R3K	FXD CHIP 3.3kΩ ±5% 1/10W	
R469	RCP-AN680K	FXD CHIP 680kΩ ±5% 1/10W	
R470	RCP-AN680	FXD CHIP 680Ω ±5% 1/10W	

R3261/3361
IF SECTION
BLQ-015668 (16/20)

Parts No.	Advantest Stock No.	Description	Note
R471	RCP-AN220K	FXD CHIP 220kΩ ±5% 1/10W	
R472	RCP-AN10K	FXD CHIP 10kΩ ±5% 1/10W	
R473	RVR-DF1K	VAR 1kΩ ±20% 1/2W	
R474	RCP-AN62K	FXD CHIP 62kΩ ±5% 1/10W	
R475	RCP-AN330	FXD CHIP 330Ω ±5% 1/10W	
R476	RCP-AN15K	FXD CHIP 15kΩ ±5% 1/10W	
R477	RCP-AN4R7K	FXD CHIP 4.7kΩ ±5% 1/10W	
R480	RCP-AN1K	FXD CHIP 1kΩ ±5% 1/10W	
R481	RCP-AN15K	FXD CHIP 15kΩ ±5% 1/10W	
R482	RCB-AG22K		
R483	RCP-AN2R2K	FXD CHIP 2.2kΩ ±5% 1/10W	
R484	RCP-AN82	FXD CHIP 82Ω ±5% 1/10W	
R485	RCP-AN2R2K	FXD CHIP 2.2kΩ ±5% 1/10W	
R486	RCP-AN82	FXD CHIP 82Ω ±5% 1/10W	
R487	RCP-AN10K	FXD CHIP 10kΩ ±5% 1/10W	
R488	RCP-AN1K	FXD CHIP 1kΩ ±5% 1/10W	
R489	RCP-AN1K	FXD CHIP 1kΩ ±5% 1/10W	
R490	RCP-AN15	FXD CHIP 15Ω ±5% 1/10W	
R491	RCP-AN39	FXD CHIP 39Ω ±5% 1/10W	
R492	RCP-AN330	FXD CHIP 330Ω ±5% 1/10W	
R493	RCP-AN1K	FXD CHIP 1kΩ ±5% 1/10W	
R494	RCP-AN100K	FXD CHIP 100kΩ ±5% 1/10W	
R495	RCP-AN1R5K	FXD CHIP 1.5kΩ ±5% 1/10W	
R496	RCP-AN2R7K	FXD CHIP 2.7kΩ ±5% 1/10W	
R497	RCP-AN47K	FXD CHIP 47kΩ ±5% 1/10W	
R501	RCP-AN180K	FXD CHIP 180kΩ ±5% 1/10W	
R503	RCP-AN10K	FXD CHIP 10kΩ ±5% 1/10W	
R504	RVR-DF10K	VAR 10kΩ ±20% 1/2W	
R505	RCP-AN2K	FXD CHIP 2kΩ ±5% 1/10W	
R506	RCP-AN1R5K	FXD CHIP 1.5kΩ ±5% 1/10W	
R509	RCP-AN510	FXD CHIP 510Ω ±5% 1/10W	
R511	RAY-TL4R7K4	FXD RA 4.7kΩ x4 ±5% 1/8W	
R512	RCP-AN100K	FXD CHIP 100kΩ ±5% 1/10W	
R513	RCP-AN10K	FXD CHIP 10kΩ ±5% 1/10W	
R515	RCP-AN3R3K	FXD CHIP 3.3kΩ ±5% 1/10W	
R517	RVR-DF5K	VAR 5kΩ ±20% 1/2W	
R518	RVR-DF20K	VAR 20kΩ ±20% 1/2W	
R519	RCP-AN4R7K	FXD CHIP 4.7kΩ ±5% 1/10W	
R521	RCP-AN10K	FXD CHIP 10kΩ ±5% 1/10W	
R522	RCP-AN4R7K	FXD CHIP 4.7kΩ ±5% 1/10W	

R3261/3361
 IF SECTION
 BLQ-015668 (17/20)

Parts No.	Advantest Stock No.	Description					Note
R524	RCP-AN7R5K	FXD	CHIP	7.5k Ω	$\pm 5\%$	1/10W	
R525	RVR-DR2K	VAR		2k Ω	$\pm 20\%$	1/2W	
R526	RCP-AN510	FXD	CHIP	510 Ω	$\pm 5\%$	1/10W	
R527	RCP-AN820	FXD	CHIP	820 Ω	$\pm 5\%$	1/10W	
R528	RCP-AN1K	FXD	CHIP	1k Ω	$\pm 5\%$	1/10W	
R529	RVR-DR1K	VAR		1k Ω	$\pm 20\%$	1/2W	
R531	RCP-AN2K	FXD	CHIP	2k Ω	$\pm 5\%$	1/10W	
R532	RCP-AN10	FXD	CHIP	10 Ω	$\pm 5\%$	1/10W	
R534	RCP-AN220	FXD	CHIP	220 Ω	$\pm 5\%$	1/10W	
R535	RCP-AN3R3K	FXD	CHIP	3.3k Ω	$\pm 5\%$	1/10W	
R536	RCP-AN2R2K	FXD	CHIP	2.2k Ω	$\pm 5\%$	1/10W	
R537	RCP-AN1K	FXD	CHIP	1k Ω	$\pm 5\%$	1/10W	
R538	RCP-AN22K	FXD	CHIP	22k Ω	$\pm 5\%$	1/10W	
R542	RCP-AN4R7K	FXD	CHIP	4.7k Ω	$\pm 5\%$	1/10W	
R543	RCP-AN22K	FXD	CHIP	22k Ω	$\pm 5\%$	1/10W	
R545	RCP-AN3R3K	FXD	CHIP	3.3k Ω	$\pm 5\%$	1/10W	
R546	RCP-AN10K	FXD	CHIP	10k Ω	$\pm 5\%$	1/10W	
R550	RCP-AN4R7K	FXD	CHIP	4.7k Ω	$\pm 5\%$	1/10W	
R551	RCP-AN3R3K	FXD	CHIP	3.3k Ω	$\pm 5\%$	1/10W	
R552	RCP-AN4R7K	FXD	CHIP	4.7k Ω	$\pm 5\%$	1/10W	
R553	RCP-AN33K	FXD	CHIP	33k Ω	$\pm 5\%$	1/10W	
R554	RCP-AN10K	FXD	CHIP	10k Ω	$\pm 5\%$	1/10W	
R555	RCP-AN5R1K	FXD	CHIP	5.1k Ω	$\pm 5\%$	1/10W	
R556	RCP-AJ10K	FXD	CHIP	10k Ω	$\pm 5\%$	1/10W	
R557	RCP-AN10K	FXD	CHIP	10k Ω	$\pm 5\%$	1/10W	
R558	RCP-AN8R2K	FXD	CHIP	8.2k Ω	$\pm 5\%$	1/10W	
R559	RCP-AN8R2K	FXD	CHIP	8.2k Ω	$\pm 5\%$	1/10W	
R560	RCP-AN10K	FXD	CHIP	10k Ω	$\pm 5\%$	1/10W	
R561	RVR-DF100	VAR		100 Ω	$\pm 20\%$	1/2W	
R562	RCP-AN100K	FXD	CHIP	100k Ω	$\pm 5\%$	1/10W	
R564	RCP-AN22K	FXD	CHIP	22k Ω	$\pm 5\%$	1/10W	
R565	RCP-AN3R3K	FXD	CHIP	3.3k Ω	$\pm 5\%$	1/10W	
R566	RCP-AN10K	FXD	CHIP	10k Ω	$\pm 5\%$	1/10W	
R567	RCP-AN10K	FXD	CHIP	10k Ω	$\pm 5\%$	1/10W	
R568	RVR-DF100	VAR		100 Ω	$\pm 20\%$	1/2W	
R569	RCP-AN1R2K	FXD	CHIP	1.2k Ω	$\pm 5\%$	1/10W	
R570	RCP-AN10K	FXD	CHIP	10k Ω	$\pm 5\%$	1/10W	
R571	RCP-AN3R3K	FXD	CHIP	3.3k Ω	$\pm 5\%$	1/10W	
R572	RVR-DF100	VAR		100 Ω	$\pm 20\%$	1/2W	
R573	RCP-AN22K	FXD	CHIP	22k Ω	$\pm 5\%$	1/10W	

R3261/3361
 IF SECTION
 BLQ-015668 (18/20)

Parts No.	Advantest Stock No.	Description	Note
R574	RCP-AN3R3K	FXD CHIP 3.3k Ω \pm 5% 1/10W	
R575	RCP-AN4R7K	FXD CHIP 4.7k Ω \pm 5% 1/10W	
R576	RCP-AN1K	FXD CHIP 1k Ω \pm 5% 1/10W	
R579	RCP-AN1K	FXD CHIP 1k Ω \pm 5% 1/10W	
SW1	SHB-001544	DIODE SWITCH	
SW2	SHB-001543	DIODE SWITCH	
SW4	SHB-001544	DIODE SWITCH	
SW5	SHB-001543	DIODE SWITCH	
SW6	SHB-001544	DIODE SWITCH	
SW7	SHB-001543	DIODE SWITCH	
SW8	SHB-001544	DIODE SWITCH	
TP1	JTE-AH001JX01	TERMINAL	
TP7	JTE-AH001JX01	TERMINAL	
TP12	JTE-AH001JX01	TERMINAL	
TP501	JTE-AH001JX01	TERMINAL	
TP502	JTE-AH001JX01	TERMINAL	
TP507	JTE-AH001JX01	TERMINAL	
U1	SHB-001855	VIDEO AMP	
U3	SHB-001858	VIDEO AMP	
U5	SHB-001858	VIDEO AMP	
U6	SHB-001857	VIDEO AMP	
U8	SHB-001855	VIDEO AMP	
U13	SIA-TL072S	OP AMP Dual Low Noise	
U17	SIT-74075	Hex Buffer (Open Collector High Voltage)	
U21	SIT-74LS00S	QUAD 2 INPUT POSI-NAND	
U22	SHB-001856	VIDEO AMP	
U23	SHB-001857	VIDEO AMP	
U25	SHB-001855	VIDEO AMP	
U26	SHB-001858	VIDEO AMP	
U28	SHB-001855	VIDEO AMP	
U29	SHB-001855	VIDEO AMP	
U30	SHB-001484	VIDEO AMP	
U39	SHB-001857	VIDEO AMP	
U40	SIA-318	OP AMP	
U41	SIA-TL072S	OP AMP Dual Low Noise	
U42	SIM-CXD108S	I/O Expander	
U43	SIA-412	OP AMP Dual Low Drift, Low Offset	
U44	SIT-74LS32S	QUAD 2 INPUT POSI-OR	
U45	SIA-TL072S	OP AMP Dual Low Noise	
U46	SIA-357	OP AMP Wide Band Ac Compensated	

R3261/3361
IF SECTION
BLQ-015868 (18/20)

Parts No.	Advantest Stock No.	Description	Note
U47	SIA-318	OP AMP	
U48	SIA-TL072S	OP AMP Dual Low Noise	
U49	SIA-TL072S	OP AMP Dual Low Noise	
U50	SIA-TL072S	OP AMP Dual Low Noise	
U52	SIA-393S-1	Comparator Dual Low Power Low Offset	
U53	SIA-318	OP AMP	
U54	SIA-412	OP AMP Dual Low Drift, Low Offset	
U55	SIA-TL072S	OP AMP Dual Low Noise	
U57	SIT-74LS32S	QUAD 2 INPUT POSI-OR	
U58	SIM-CXD109S	I/O Expander	
U59	SIA-DG201S-1	QUAD Analog Switches	
U60	SIT-74LS88S	QUAD 2 INPUT EXCLUSIVE-OR	
U61	SIT-74LS221S	DUAL MONOS TABLE MULTIVIBRATORS	
U62	SIA-DG201S	QUAD Analog Switches	
U63	SIM-TC4S71F	DUAL INPUT OR	
U64	SIT-7406S	Hex Inverter (Open Collector High Voltage)	
U66	SIT-DN8850	Low-Active Drivers	
U68	SIT-DN8850	Low-Active Drivers	
U69	SIA-4068	QUAD Analog Switches	
U73	SIT-74LS122S	Monostable Multivibrator	
U74	SIA-TL072S	OP AMP Dual Low Noise	
U75	SIA-DG201S-1	QUAD Analog Switches	
U76	SIA-1218	12-BIT D/A Converters	
U77	SIM-TC4S69F	INVERT GATE	
U78	SIA-TL072S	OP AMP Dual Low Noise	
U80	SIM-TC4S71F	DUAL INPUT OR	
U81	SIM-TC4S81F	DUAL INPUT AND	
U82	SIM-TC4S71F	DUAL INPUT OR	
U83	SIM-TC4S81F	DUAL INPUT AND	
U501	SIM-74HC04S	HEX INVERTER	
U502	SIM-74HC05S	HEX BUFFER (OPEN DRAIN)	
U503	SIM-653820U	Custom Made	
U504	SIA-DAC703J	16-BIT D/A Converters	
U505	SIA-TL071CPS-1	OP AMP Low Noise	
U506	SIA-TL072CPS	OP AMP Dual Low Noise	
U508	SIA-DG201S-1	QUAD Analog Switches	
U509	SIM-74HC107S	Dual j-k Flip-Flops With Clear	
U510	SIM-CXD109S	I/O Expander	
U511	SIM-74HC32S	QUAD 2-INPUT POSI-OR	
U512	SIM-74HC138S	Dual 2 To 4-line Decoders	

R3261/3361
 IF SECTION
 BLQ-015668 (20/20)

Parts No:	Advanstest Stock No.	Description	Note
U513	SIM-74HC08S	QUAD 2-INPUT POSI-AND	
U514	SIM-74HC174S	Hex D Flip-Flops	
U515	SIM-74HC107S	Dual J-K Flip-Flops With Clear	
U518	SIM-74HC08S	QUAD 2-INPUT POSI-AND	
U519	SIM-74HC00S	QUAD 2 INPUT POSI-NAND	
U520	SIM-74HC04S	HEX INVERTER	
U521	SIM-74HC174S	HEX D FLIP-FLOPS	
U522	SIM-74HC14S	HEX Schmitt-Trigger Inverters	
U523	SIM-TC7S04F	INVERT GATE	
U524	SIM-74HC74S	Dual D Flip-Flops With Preset and Clear	
U526	SIM-74HC157S	QUAD 2 TO 1-LINE DATA SELECTORS	
U527	SIA-311S-1	Comparator	
U529	SIA-393S-1	Comparator Dual Low Power Low Offset	
U530	SIA-TL072CPS	OP AMP Dual Low Noise	
U531	SIA-79L05	Voltage Regulator	
U532	SIA-REF01D	Voltage Regulator	
U533	SIA-TL072CPS	OP AMP Dual Low Noise	
U535	SIA-5012*KP24	16-Bit A/D Converters	
U536	SIM-74HC574S	Octal D Flip-Flops	
U538	SIA-TL072CPS	OP AMP Dual Low Noise	
U539	SIA-393S-1	Comparator Dual Low Power Low Offset	
U541	SIA-DG201S-1	QUAD Analog Switches	
U542	SIA-TL071CPS-1	OP AMP Low Noise	
U543	SIA-DG201S-1	QUAD Analog Switches	
U544	SIA-393S-1	Comparator Dual Low Power Low Offset	
U545	SIM-74HC4538S	Monostable Multivibrator	
U547	SIM-74HC08S	QUAD 2 INPUT POSI-AND	
U548	SHB-002610	Peak Detector	
U551	SIM-74HC74S	Dual D Flip-Flops With Preset and Clear	
X1	DXD-001898-11	CRYSTAL	
X2	DXD-001898-11	CRYSTAL	
X3	DXD-001898-11	CRYSTAL	
X4	DXD-001898-11	CRYSTAL	

R3261/3361
CPU
BLQ-015869 (1/4)

Parts No.	Advantest Stock No.	Description				Note
C1	CCK-CM100U25V	FXD	ELECT	100 μ F	\pm 20%	25V
C4	CCK-CM100U16V	FXD	ELECT	100 μ F	\pm 20%	16V
C5	CCK-BY1000U10V	FXD	ELECT	1000 μ F	\pm 20%	10V
C6	CCK-CM100U16V	FXD	ELECT	100 μ F	\pm 20%	16V
C9	CCK-BX470U16V	FXD	ELECT	470 μ F	\pm 20%	16V
C12	CTA-AC3R3U16V	FXD	TA	3.3 μ F	\pm 20%	16V
C17	CTA-AC10U16V	FXD	TA	10 μ F	\pm 20%	16V
C18	CSM-BA470P50V	FXD	CER	470PF	\pm 10%	50V
C19	CSM-AY1000P50V	FXD	CER	1000PF	\pm 10%	50V
C21	CSM-AGR1U50V	FXD	CER	33PF	\pm 10%	50V
C26	CSM-AGR1U50V	FXD	CER	0.1 μ F	\pm 10%	50V
C61	CSM-AGR1U50V	FXD	CER	0.1 μ F	\pm 10%	50V
D1	SDS-1SS270		DIODE SI			
D5	SDS-1SS270		DIODE SI			
D7	SDS-1SS270		DIODE SI			
J1	JCS-BQ128PX01		ZENER DIODE			
J2	JCR-AF026PX02		CONNECTOR			
J3	JCR-AF030PX02		CONNECTOR			
J5	JCF-AC001JX01		CONNECTOR			
L1	LCL-C00010		COIL	180 μ H	\pm 10%	
L2	LCL-T00084A		COIL	CUSTOM DEVICE		
Q1	STN-2SC1815		TRANSISTOR	NPN		
Q2	STN-2SC1815		TRANSISTOR	NPN		
Q3	STN-2SC1815		TRANSISTOR	NPN		
Q4	STN-2SC1815		TRANSISTOR	NPN		
Q5	STP-2SA1015		TRANSISTOR	PNP		
Q6	STN-2SC2901		TRANSISTOR	NPN		
Q8	STP-UN4114		TRANSISTOR	PNP		
R1	RAY-TL3R9K8	FXD	RA	3.9k Ω \times 8	\pm 5%	1/8W
R16	RAY-RL1K6	FXD	RA	1k Ω \times 6	\pm 5%	1/8W
R18	RAY-TL33K4	FXD	RA	33k Ω \times 4	\pm 5%	1/8W
R24	RCB-AH1R2K	FXD	CAR	1.2k Ω	\pm 5%	1/4W
R25	RCB-AG6R8K	FXD	CAR	6.8k Ω	\pm 5%	1/8W
R27	RCB-AG68	FXD	CAR	68 Ω	\pm 5%	1/8W
R28	RCB-AG1R5K	FXD	CAR	1.5k Ω	\pm 5%	1/8W
R29	RCB-AG220	FXD	CAR	220 Ω	\pm 5%	1/8W
R30	RCB-AG3R3K	FXD	CAR	3.3k Ω	\pm 5%	1/8W
R31	RCB-AG820	FXD	CAR	820 Ω	\pm 5%	1/8W
R32	RCB-AG10K	FXD	CAR	10k Ω	\pm 5%	1/8W
R33	RCB-AG390	FXD	CAR	390 Ω	\pm 5%	1/8W

R3261/3361
CPU
BLQ-015669 (2/4)

Parts No.	Advantest Stock No.	Description	Note
R34	RCB-AG2R2K	FXD CAR 2.2kΩ ±5% 1/8W	
R37	RCB-AG2R2K	FXD CAR 2.2kΩ ±5% 1/8W	
R39	RCB-AG500	FXD CAR 560Ω ±5% 1/8W	
R40	RCB-AG120	FXD CAR 120Ω ±5% 1/8W	
R41	RCB-AG220	FXD CAR 220Ω ±5% 1/8W	
R42	RCB-AG800	FXD CAR 680Ω ±5% 1/8W	
R43	RCB-AG3R3K	FXD CAR 3.3kΩ ±5% 1/8W	
R44	RCB-AG100	FXD CAR 100Ω ±5% 1/8W	
R45	RCB-AG470	FXD CAR 470Ω ±5% 1/8W	
R46	RCB-AG220	FXD CAR 220Ω ±5% 1/8W	
R48	RCB-AG800	FXD CAR 680Ω ±5% 1/8W	
R49	RCB-AG220	FXD CAR 220Ω ±5% 1/8W	
R50	RCB-AG330	FXD CAR 330Ω ±5% 1/8W	
R51	RCB-AG8R8K	FXD CAR 6.8kΩ ±5% 1/8W	
R52	RCB-AG1R5K	FXD CAR 1.5kΩ ±5% 1/8W	
R54	RCB-AG820	FXD CAR 820Ω ±5% 1/8W	
R56	RCB-AG10K	FXD CAR 10kΩ ±5% 1/8W	
R57	RCB-AG82K	FXD CAR 82kΩ ±5% 1/8W	
R58	RCB-AG10K	FXD CAR 10kΩ ±5% 1/8W	
R59	RCB-AG470	FXD CAR 470Ω ±5% 1/8W	
R60	RCB-AG1K	FXD CAR 1kΩ ±5% 1/8W	
R61	RCB-AG10K	FXD CAR 10kΩ ±5% 1/8W	
R62	RCB-AG330	FXD CAR 330Ω ±5% 1/8W	
R65	RVR-AK2K	VAR 2kΩ ±20% 1/2W	
TP1	JTE-AH001.JX01		
U1	SIM-74HC4538S	MONOSTABLE MULTIVIBRATORS WITH CLEAR	
U2	SIM-74HC74S	DUAL-D FLIP-FLOPS WITH PRESET & CLEAR	
U4	SIM-74HC245S	OCTAL BUS TRANCEIVERS	
U8	SIM-74HC244S	OCTAL BUFFERS	
U9	SIM-74HC32S	QUAD 2-INPUT POSI-OR GATES	
U10	SIM-74HC08S	QUAD 2-INPUT POSI-AND GATES	
U12	SIM-74HC273S	OCTAL D-TYPE FLIP-FLOPS	
U13	SIM-74HC367S	HEX BUS DRIVERS	
U16	SIM-74HC245S	OCTAL BUS TRANCEIVERS	
U18	SIM-74HC08S	QUAD 2-INPUT POSI-AND GATES	
U19	SIM-74HC74S	DUAL-D FLIP-FLOPS WITH PRESET & CLEAR	
U20	SIM-74HC139S	DUAL 2 TO 4-LINE DECODERS	
U21	SIM-74HC161S	SYNCHRONOUS 4-BIT BINARY COUNTERS	
U22	SIM-74HC148S	8-LINE TO 3-LINE OCTAL PRIORITY ENCODERS	
U23	SIM-74HC04S	HEX INVERTERS	

R3261/3361
CPU
BLQ-015889 (3/4)

Parts No.	Advantest Stock No.	Description	Note
U24	SIM-74HC374S	OCTAL D-FLIP-FLOPS	
U25	SIM-74HC390S	DUAL DECADE COUNTERS	
U27	SIM-74HC166S	8-BIT SHIFT REGISTERS	
U28	SIM-74HC166S	8-BIT SHIFT REGISTERS	
U30	SIM-74HC04S	HEX INVERTERS	
U31	SIM-74HC32S	QUAD 2-INPUT POSI-OR GATES	
U32	SIM-74HC20S	DUAL 4-INPUT POSI-NAND GATES	
U33	SIM-74HC367S	HEX BUS DRIVERS	
U34	SIM-74HC138S	3 TO 8-LINE DECODERS	
U35	SIT-74F244S	OCTAL BUFFERS	
U36	SIT-74F175S	QUAD D-FLIP-FLOPS	
U37	SMM-4461A	65536-WORD x 4-BIT VIDEO RAM	
U41	SIT-74AS74S	DUAL D FLIP FLOPS WITH PRESET & CLAER	
U42	SIM-74HC390S	DUAL DECADE COUNTERS	
U43	SIM-74HC74S	DUAL D FLIP FLOPS WITH PRESET & CLAER	
U45	SIM-74HC08S	QUAD 2-INPUT DOKS-AND GATES	
U46	SMM-65812BLP12	131072-WORD x 8Bt PSEUDO STATIC RAM	
U47	SIM-74HC393S	DUAL 4-BIT BINARY COUNTERS	
U48	SIM-74HC86S	QUAD 2-INPUT EXCLUSIVE OR GATES	
U49	SIM-74HC74S	DUAL D FLIP-FLOPS WITH PRESET & CLAER	
U50	SIM-74HC04S	HEX INVERTERS	
U51	SIM-74HC138S	3 TO 8-LINE DECODERS	
U52	SIM-95C80*16KC	GRAPHIC CONTROLLER	
U53	SIM-74HC166S	8-BIT SHIFT REGISTERS	
U54	SIM-74HC166S	8-BIT SHIFT REGISTERS	
U56	SMM-4461A	65536-WORD x 4-BIT VIDEO RAM	
U60	SIM-74HC74S	DUAL D FLIP-FLOPS WITH PRESET & CLAER	
U61	SIM-74HC02S	QUAD 2-INPUT POSI-NOR GATES	
U62	SIT-74AS74S	DUAL D FLIP-FLOPS WITH PRESET & CLAER	
U63	SIM-74HC367S	HEX BUS DRIVERS	
U64	SIM-8254S	PROGRAMMABLE COUNTER/TIMER	
U65	SMM-65812BLP12	131072-WORD x 8Bt PSEUDO STATIC RAM	
U66	SIM-74HC04S	HEX INVERTERS	
U67	SIM-74HC164S	8-BIT PARALLEL OUTPUT SERIAL SHIFT REGISTERS	
U68	SIM-74HC32S	QUAD 2 INPUT POSI AND GATES	
U69	SIM-74HC30S	8-INPUT POSI NAND GATES	
U70	SIM-74HC08S	QUAD 2 INPUT POSI AND GATES	
U71	SIM-74HC107S	DUAL J-K FLIP-FLOPS WITH CLEAR	
U72	SIM-74HC04S	HEX INVERTERS	
U73	SIM-74HC00S	DUAL INPUT POSI-NAND GATES	

R3261/3361
CPU
BLQ-015669 (44)

Parts No.	Advantest Stock No.	Description	Note
U75	SIM-74HC08S	QUAD 2 INPUT POSI AND GATES	
U76	SIM-74HC74S	DUAL D FLIP-FLOPS WITH PRESET & CLEAR	
U77	SIM-74HC139S	DUAL 2 TO 4-LINE DECODERS	
U78	SIM-74HC107S	DUAL J-K FLIP-FLOPS WITH CLEAR	
U79	SIM-6254S	PROGRAMMABLE COUNTER/TIMER	
U80	SMM-27C1001A	131072-WORD x 8BIT EPROM	
U81	SMM-28PC64*15-1	8k WORD x 8BIT EEPROM	
U82	SIM-854815	DECODER & CLOCK GENERATOR	
U83	SIM-74HC32S	QUAD 2-INPUT POSI-OR GATES	
U84	SIM-74HC4538S	DUAL MONOSTABLE MULTIVIBRATORS WITH CLEAR	
U85	SMM-27C1001A	131072-WORD x 8BIT EEPROM	
U86	SMM-28PC64*15-1	8k WORD x 8BIT EEPROM	
U87	SIT-74F244S	OCTAL BUFFERS	
U89	SIM-74HC168S	8-BIT SHIFT REGISTERS	
U91	SMM-4461A	65536-WORD x 4-BIT VIDEO RAM	
U95	SIM-74HC05S	HEX INVERTERS (OPEN ARRAY)	
U96	SIM-74HC14S	HEX SCHMITT-TRIGGER INVERTERS	
U97	SIM-74HC273S	OCTAL D FLIP-FLOPS	
U98	SIM-61H06B23F	KEY CONTROLLER	
U99	SMM-27C1001A	131072-WORD x 8BIT EPROM	
U100	SIM-68HC000C	16-BIT MICROPROCESSOR	
U101	SIM-6914	GP-4B CONTROLLER	
U102	SIM-74HC168S	8-BIT SHIFT REGISTERS	
U104	SIA-TL7700	VOLTAGE COMPARATER	
U106	SIT-74AS32S	QUAD 2-INPUT POSI-OR GATES	
U108	SMM-27C1001A	131072-WORD x 8BIT EPROM	
U109	SIT-75160	OCTAL GP-AB TRANSCIVERS	
U110	SIT-75161	OCTAL GP-AB TRANSCIVERS	
U111	SMM-4461A	65536-WORD x 4-BIT VIDEO RAM	
X1	DXC-001716	CRYSTAL OSC	

R3261/3361
TG KEY
BLB-015775 (1/1)

Parts No.	Advantest Stock No.	Description	Note
D1 J1 S1	NLD-000010 DCB-QS1272002-1 KSP-000609	LED CABLE ASSEMBLY SWITCH	

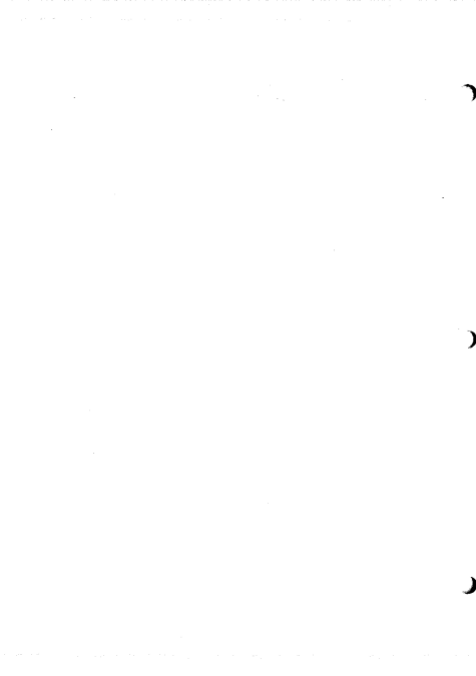

R3261/3361
KEY
BLQ-015673 (1/1)

Parts No.	Advantest Stock No.	Description	Note
D1-3 D4 D5 J1 J2	NLD-000010 NLD-000111 NLD-000010 DCB-RR1792X03-1 JCP-BH005PX02	LED LED LED CONNECTOR CONNECTOR	
R1-6 S1-6 S7-42	RCB-AG680 KSP-000888 KSP-000609	FXD CAR 660Ω ±5% 1/8W SWITCH SWITCH	

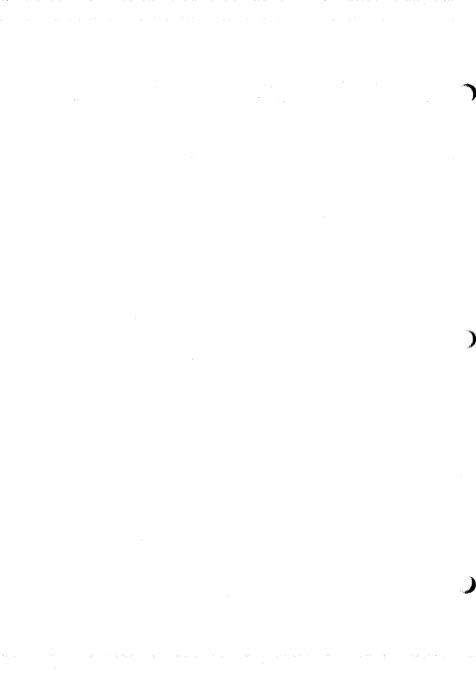

R3261/3361
RF BLOCK
WBL-3261RF (1/1)

Parts No.	Avantest Stock No.	Description	Note
	BLB-015646 BLB-015647 BLB-015727 BLC-015650 BLG-015645		
	BLH-015667 BLK-015649 BTB-015641 BTB-015642 BTB-016118		
	BDT-015644 DCB-FQ1170X01-1 JCS-AD010JX01-1 JTM-BL001JX01 JTM-BP001JX01	CABLE ASSEMBLY CONNECTOR CONNECTOR CONNECTOR	
C1	CFT-AK220P50V	FXD COAXIAL 220PF +100%, -0% 50V	
C2	CSM-TG1U50V	FXD CER 1 μ F +80%, -20% 50V	
CB3	DCB-FF3828X14-1	CABLE ASSEMBLY	
CB4	DCB-FF3828X09-1	CABLE ASSEMBLY	
CB5	DCB-FF3828X00-1	CABLE ASSEMBLY	
CB7	DCB-FF0971X11A-1	CABLE ASSEMBLY	
CB8	DCB-FF0971X09A-1	CABLE ASSEMBLY	
CB9	DCB-FF3828X06-1	CABLE ASSEMBLY	
CB10	DCB-FF3828X06-1	CABLE ASSEMBLY	
CB11	DCB-FQ3829X01-1	CABLE ASSEMBLY	
CB12	DCB-QR3831X01-1	CABLE ASSEMBLY	
FL1	DNF-001052	EMI FILTER	
FL32	DNF-001052	EMI FILTER	
FL40	DEE-001830	4GHz COAXIAL LPF	
J1	JCF-AF001JX09	CONNECTOR	
J2	JCF-AC001JX02	CONNECTOR	
J9	JCF-AC001JX02	CONNECTOR	
J10	JCF-AF003JX05-3	CONNECTOR	
J11	JCS-AV004JX01	CONNECTOR	
J12	JCR-AE010JX02	CONNECTOR	
J13	YEE-000734-1	CONNECTOR	
L1	LCL-B00820	COIL 33 μ H \pm 10%	
OS1	DXY-001884-1	TOP-1244 YTO (CUSTOM DEVICE)	

R3261/3361
RF BLOCK
WBL-3361RF (1/1)

Parts No.	Advantest Stock No.	Description	Note
	BLB-015646 BLB-015647 BLB-015727 BLC-015650 BLG-015645		
	BLH-015657 BLK-015649 BTB-015641 BTB-015642 BTB-016118		
	BTD-015644 DCB-FQ1170X01-1 DCB-FQ1170X02-1 JCS-AD010JX01-1 JTM-BL001JX01	CABLE ASSEMBLY CABLE ASSEMBLY CONNECTOR CONNECTOR	
C1	JTM-8P001JX01	CONNECTOR	
C2	CFT-AK220P80V	FXD COAXIAL 220PF +100%, -0% 50V	
C3	CSM-TG1U50V	FXD CER 1 μ F +80%, -20% 50V	
CB3	DCB-FF3828X14-1	CABLE ASSEMBLY	
CB4	DCB-FF3828X06-1	CABLE ASSEMBLY	
CB6	DCB-FF0971X12A-1	CABLE ASSEMBLY	
CB7	DCB-FF0971X11A-1	CABLE ASSEMBLY	
CB8	DCB-FF0971X09A-1	CABLE ASSEMBLY	
CB9	DCB-FF3828X06-1	CABLE ASSEMBLY	
CB10	DCB-FF3828X06-1	CABLE ASSEMBLY	
CB11	DCB-FQ3828X01-1	CABLE ASSEMBLY	
CB12	DCB-QR3831X01-1	CABLE ASSEMBLY	
FL1	DNF-001052	EMI FILTER	
FL32	DNF-001052	EMI FILTER	
FL40	DEE-001830	4GHz COAXIAL LFF	
J1	JCF-AF001JX00	CONNECTOR	
J2	JCF-AC001JX02	CONNECTOR	
J9	JCF-AC001JX02	CONNECTOR	
J10	JCI-AF003JX05-3	CONNECTOR	
J11	JCS-AV004JX01	CONNECTOR	
J12	JCR-AE010JX02	CONNECTOR	
J13	YEE-000734-1	CONNECTOR	
L1	LCL-B00520	COIL 33 μ H \pm 10%	
OS1	DXY-001864	TOP-1244 YTO (CUSTOM DEVICE)	

R3261/3361
 CAL AMP
 BLB-015646 (1/1)

Parts No.	Advantest Stock No.	Description	Note
C1	CCK-BX10U25V	FXD ELECT 10 μ F \pm 20% 25V	
C3	CCP-BAR01U50V	FXD CHIP 0.01 μ F \pm 10% 50V	
C5	CCK-BX10U25V	FXD ELECT 10 μ F \pm 20% 25V	
C6	CCP-BAR01U50V	FXD CHIP 0.01 μ F \pm 10% 50V	
C7	CCP-BBR1U50V	FXD CHIP 0.1 μ F \pm 20% 50V	
C10	CCP-BAR01U50V	FXD CHIP 0.01 μ F \pm 10% 50V	
C11	CCP-AV120PR1K	FXD CHIP 120PF +5%, -20% 100V	
C13	CCP-BAR01U50V	FXD CHIP 0.01 μ F \pm 10% 50V	
J1	JCF-8A001JX01	CONNECTOR	
L1	LCL-C00010	COIL 180 μ H \pm 10%	
L3	LCL-E00944	COIL CHIP 220nH \pm 10%	
L4	LCL-E00948	COIL CHIP 0.39 μ H \pm 20%	
L5	LCL-E00944	COIL CHIP 220nH \pm 10%	
Q1	STN-2SC3396	TRANSISTOR NPN	
Q3	STN-2SC1623	TRANSISTOR NPN	
R1	RCP-AN51	FXD CHIP 51 Ω \pm 0.5% 1/10W	
R3	RCP-AJ51	FXD CHIP 51 Ω \pm 5% 1/10W	
R5	RCP-AJ390	FXD CHIP 390 Ω \pm 5% 1/10W	
R6	RCP-AJ51	FXD CHIP 51 Ω \pm 5% 1/10W	
R7	RCP-AJ5R8K	FXD CHIP 5.6k Ω \pm 5% 1/10W	
R8	RCP-AJ10K	FXD CHIP 10k Ω \pm 5% 1/10W	
R9	RCP-AN68	FXD CHIP 68 Ω \pm 0.5% 1/10W	
R10	RCP-AN130	FXD CHIP 130 Ω \pm 0.5% 1/10W	
R11	RCP-AN68	FXD CHIP 68 Ω \pm 0.5% 1/10W	
R12	RCP-AN4R3K	FXD CHIP 4.3k Ω \pm 0.5% 1/10W	
R13	RCP-AN2R7K	FXD CHIP 2.7k Ω \pm 0.5% 1/10W	
R14	RCP-AN1K	FXD CHIP 1k Ω \pm 0.5% 1/10W	
R15	RCP-AN1R2K	FXD CHIP 1.2k Ω \pm 0.5% 1/10W	
R16	RVR-DF100	VAR 100 Ω \pm 20% 1/2W	
R17	RCP-AN16K	FXD CHIP 16k Ω \pm 0.5% 1/10W	
R18	RVR-DF2K	VAR 2k Ω \pm 20% 1/2W	
R19	RCP-AN15K	FXD CHIP 15k Ω \pm 0.5% 1/10W	
R20	RCP-AN100K	FXD CHIP 100k Ω \pm 0.5% 1/10W	
U1	SIA-OP07PS	OP AMP ULTRA-LOW OFFSET	

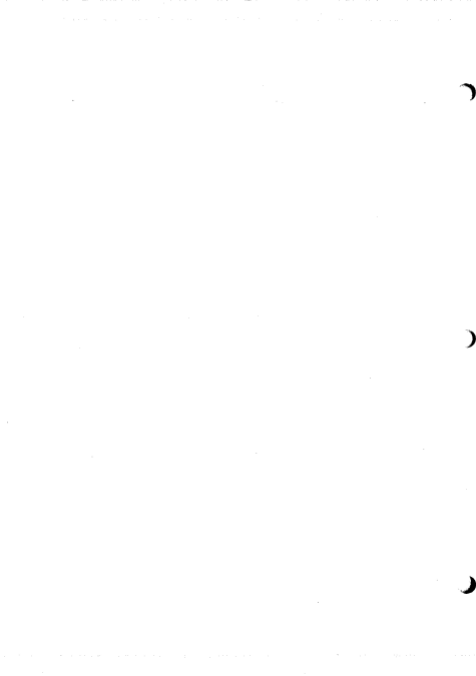

R3261/3361
 YTO DRIVER
 BLQ-015647 (1/2)

Parts No.	Advantest Stock No.	Description				Note	
C1	CSM-AGR1U50V	FXD	CER	0.1 μ F	+80%, -20%	50V	
C2	CSM-AC33P50V	FXD	CER	33PF	\pm 10%	50V	
C3	CFM-ASR047U50V	FXD	FILM	0.047 μ F	\pm 10%	50V	
C4	CSM-AGR1U50V	FXD	CER	0.1 μ F	+80%, -20%	50V	
C5	CCK-AR100U25V	FXD	ELECT	100 μ F	\pm 20%	25V	
C6	CCK-AA470U10V	FXD	ELECT	470 μ F	\pm 20%	10V	
C8	CSM-AC1000P50V	FXD	CER	1000PF	\pm 10%	50V	
C9	CCK-AR33U18V	FXD	ELECT	33 μ F	\pm 20%	10V	
C10-11	CCK-AR10U25V	FXD	ELECT	10 μ F	\pm 20%	25V	
C12	CSM-AGR1U50V	FXD	CER	0.1 μ F	+80%, -20%	50V	
C13	CSM-AC1000P50V	FXD	CER	1000PF	\pm 10%	50V	
C14	CSM-AG1U50V	FXD	CER	1 μ F	+80%, -20%	50V	
C15-16	CSM-AGR1U50V	FXD	CER	0.1 μ F	+80%, -20%	50V	
C17	CSM-AG1U50V	FXD	CER	1 μ F	+80%, -20%	50V	
C18	CCK-AR10U25V	FXD	ELECT	10 μ F	\pm 20%	25V	
C19-20	CSM-AG1U50V	FXD	CER	1 μ F	+80%, -20%	50V	
C21	CCK-AR10U25V	FXD	ELECT	10 μ F	\pm 20%	25V	
C22- 23	CCK-AR47U25V	FXD	ELECT	47 μ F	\pm 20%	25V	
C25	CTA-AC10U25V	FXD	TA	10 μ F	\pm 20%	25V	
C26	CSM-AFR1U50V	FXD	CER	0.1 μ F	\pm 5%	50V	
C27	CSM-AFR1U50V	FXD	CER	0.1 μ F	\pm 5%	50V	
C28	CSM-BA2200P50V	FXD	CER	2200PF	\pm 5%	50V	
C29	CSM-BA2200P50V	FXD	CER	2200PF	\pm 5%	50V	
C30	CTA-AC10U25V	FXD	TA	10 μ F	\pm 20%	25V	
C31	CSM-BA2200P50V	FXD	CER	2200PF	\pm 5%	50V	
C32	CSM-BA2200P50V	FXD	CER	2200PF	\pm 5%	50V	
C33	CTA-AC10U25V	FXD	TA	10 μ F	\pm 20%	25V	
D1	SDZ-W130	ZENER	DIODE				
D2-4	SDS-LD1	DIODE SI					
D5	SDZ-D120	ZENER	DIODE				
D6	SDZ-D056	ZENER	DIODE				
J1	JCR-AF026PX02	CONNECTOR					
L1-2	LCL-C00358	COIL	(CUSTOM DEVICE)				
Q1	STN-25C2983	TRANSISTOR NPN					
Q2	STP-25A225	TRANSISTOR PNP					
Q3	STN-25C1815	TRANSISTOR NPN					
Q6-7	SFN-2N4393-18	FET	N-JUNCTION				
Q8	STN-25C2983	TRANSISTOR NPN					
Q9	STP-25A642-33	TRANSISTOR PNP					
Q10-11	STN-25C1983	TRANSISTOR NPN					
Q12	STN-25C1815	TRANSISTOR NPN					
Q13	STP-25A1225	TRANSISTOR PNP					
Q14	STP-25A1015	TRANSISTOR PNP					
Q15	STN-25C2983	TRANSISTOR NPN					
R1	RCB-AG4R7K	FXD	CAR	4.7K Ω	\pm 5%	1/8W	
R2	RCB-AK33	FXD	CAR	33 Ω	\pm 5%	1/2W	
R3	RCB-AG4R7K	FXD	CAR	4.7K Ω	\pm 5%	1/8W	
R4	RMF-AR2R2KFK	FXD	METAL	2.2K Ω	\pm 1%	1/4W	
R5	RCB-AK33	FXD	CAR	33 Ω	\pm 5%	1/2W	
R6	RCB-AG1K	FXD	CAR	1K Ω	\pm 5%	1/8W	

R3261/3361
 YTO DRIVER
 BLQ-015647 (2/2)

Parts No.	Advantest Stock No.	Description					Note
R7-9	RMF-AS100QFK	FXD	METAL	100Ω	±1%	1/2W	
R10	RMF-AS100QFK	FXD	METAL	100Ω	±1%	1/2W	
R11	RCB-AG10K	FXD	CAR	10KΩ	±5%	1/8W	
R12	RCB-AG100K	FXD	CAR	100KΩ	±5%	1/8W	
R13	RCB-AH120	FXD	CAR	120Ω	±5%	1/4W	
R14	RCB-AG100K	FXD	CAR	100KΩ	±5%	1/8W	
R15	RCB-AH220	FXD	CAR	220Ω	±5%	1/4W	
R16	RCB-AG220	FXD	CAR	220Ω	±5%	1/8W	
R17	RCB-AG1K	FXD	CAR	1KΩ	±5%	1/8W	
R25	RMF-AB8R2KFJ	FXD	METAL	8.2KΩ	±1%	1/4W	
R26	RVR-CD1K	VAR	CERMET	1KΩ	±20%	1/2W	
R27	RMF-AC100KFJ	FXD	METAL	100KΩ	±1%	1/4W	
R28	RMF-AB10KFG	FXD	METAL	10KΩ	±1%	1/4W	
R29	RCB-AH220	FXD	CAR	220Ω	±5%	1/4W	
R30	RCB-AG220	FXD	CAR	220Ω	±5%	1/8W	
R31	RCB-AG1K	FXD	CAR	1KΩ	±5%	1/8W	
R32	RCB-AG4R7K	FXD	CAR	4.7KΩ	±5%	1/8W	
R33-34	RMF-AC10KFJ	FXD	METAL	10KΩ	±1%	1/4W	
R35-36	RMF-AC12KFJ	FXD	METAL	12KΩ	±1%	1/4W	
R37	RCB-AG560	FXD	CAR	560Ω	±5%	1/8W	
R38-39	RMF-AC20KFJ	FXD	METAL	20KΩ	±1%	1/4W	
R40-41	RMF-AC10KFJ	FXD	METAL	10KΩ	±1%	1/4W	
R42	RCB-AG1K	FXD	CAR	1KΩ	±5%	1/8W	
R43	RCB-AK150	FXD	CAR	150Ω	±5%	1/8W	
R51-52	RPW-AC27-4	FXD	THERMAL	27Ω	±5%	10W	
R55	RCB-AG1R2K	FXD	CAR	1.2KΩ	±5%	1/8W	
R56	RCB-AG10K	FXD	CAR	10KΩ	±5%	1/8W	
R57	RCB-AG10K	FXD	CAR	10KΩ	±5%	1/8W	
R58	RCB-AG2R2K	FXD	CAR	2.2KΩ	±5%	1/8W	
R59	RCB-AG5R6K	FXD	CAR	5.6KΩ	±5%	1/8W	
R60	RVR-DF1K	VAR	CERMET	1KΩ	±20%	1/2W	
R61	RCB-AG3R3K	FXD	CAR	3.3KΩ	±5%	1/8W	
R62	RMF-AC10KFJ	FXD	METAL	10KΩ	±1%	1/4W	
R63	RMF-AC10KFJ	FXD	METAL	10KΩ	±1%	1/4W	
R64	RCB-AG2R2K	FXD	CAR	2.2KΩ	±5%	1/8W	
U1	SIA-5534A-1	OP AMP LOW NOISE, HIGH-SPEED, WIDE RANGE					
U3	SIA-OP07P	OP AMP LOW OFFSET					
U4	SIA-TL072-1	OP AMP DUAL LOW NOISE					
U5	SIA-TL072	OP AMP DUAL LOW NOISE					

R3261/3361
 10MHZ REF.
 BLB-015727 (1/1)

Parts No.	Advantest Stock No.	Description	Note
C1	CCP-BA100P50V	FXD CHIP 100PF $\pm 10\%$ 50V	
C2	CTA-A26R8U16V	FXD TA 6.8 μ F $\pm 20\%$ 16V	
C3	CTA-A26R8U16V	FXD TA 6.8 μ F $\pm 20\%$ 16V	
D1	SDZ-M130	ZENER DIODE	
Q1	STN-2SD1005	TRANSISTOR NPN	
R1	RCP-AJ1K	FXD CHIP 1k Ω $\pm 5\%$ 1/10W	
X1	DXC-001524	CRYSTAL 10MHz	

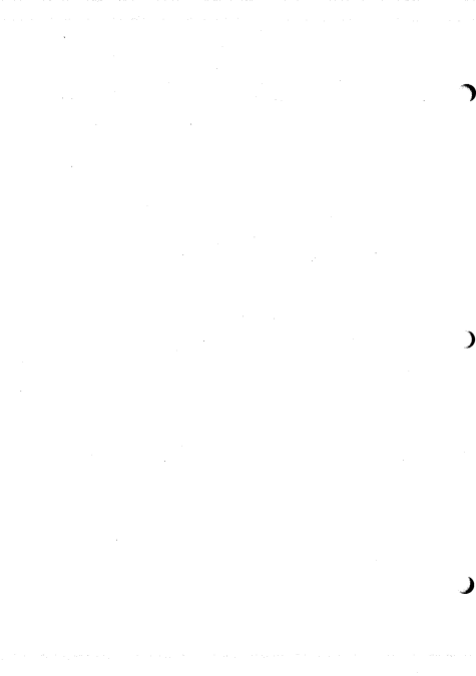

**R3251/3361
SAMPLER
BTB-016118 (1/1)**

Parts No.	Advestest Stock No.	Description	Note
C3	CCP-BA33P50V	FXD CHIP 33PF ±5% 50V	
C4	CCP-BA2P50V	FXD CHIP 2PF ±0.25% 50V	
C5	CCP-BA1P50V	FXD CHIP 1PF ±0.25% 50V	
C6	CCP-ACR5P50V	FXD CHIP 0.5PF ±0.25% 50V	
C7	CCP-BA10P50V	FXD CHIP 10PF ±0.5% 50V	
C8	CCP-BA1000P50V	FXD CHIP 1000PF ±10% 50V	
C9	CCP-BA5P50V	FXD CHIP 5PF ±0.5% 50V	
D1	SDS-1SV107	Si Snap-off DIODE	
D2	SDS-ND5051	COAS SCHOTTKY BARRIER DIODE	
D3	SDZ-W120	ZENER DIODE	
L1	LCL-A00669	COIL (CUSTOM DEVICE)	
L2	LCL-A00670	COIL (CUSTOM DEVICE)	
R1	RCP-AJ68	FXD CHIP 68Ω 1/10W	
R2	RCP-AJ100	FXD CHIP 100Ω 1/10W	
R3	RCP-AJ68	FXD CHIP 68Ω 1/10W	
R4	RCP-AJ100	FXD CHIP 100Ω 1/10W	
R6	RCP-AJ68	FXD CHIP 68Ω 1/10W	
R7	RCP-AJ100	FXD CHIP 100Ω 1/10W	
R8	RCP-AJ68	FXD CHIP 68Ω 1/10W	
R9	RCP-AJ330	FXD CHIP 330Ω 1/10W	
R10	RCP-AJ22	FXD CHIP 22Ω 1/10W	
R11	RCP-AJ330	FXD CHIP 330Ω 1/10W	
U1	SIA-UPG1108-1	ISOLATION AMP (4 to 8GHz)	



R3261/3361
VCO CONT
BLC-015850 (1/2)

Parts No.	Advantest Stock No.	Description	Note
C1	CCP-BAR01U50V	FXD CHIP 0.01 μ F \pm 10% 50V	
C2	CCK-BX2R2U50V	FXD ELECT 2.2 μ F \pm 20% 50V	
C3	CCP-BAR01U50V	FXD CHIP 0.01 μ F \pm 10% 50V	
C4	CCP-BBR1U50V	FXD CHIP 0.1 μ F +80% -20% 50V	
C6	CFM-AH4R7U100V	FXD FILM 4.7 μ F \pm 10% 100V	
C7	CCP-BBR1U50V	FXD CHIP 0.1 μ F +80% -20% 50V	
C11	CCK-BX47U35V	FXD ELECT 47 μ F \pm 20% 35V	
C12	CCK-BX100U25V	FXD ELECT 100 μ F \pm 20% 25V	
C13	CCK-BX47U35V	FXD ELECT 47 μ F \pm 20% 35V	
C14	CCK-BX47U35V	FXD ELECT 47 μ F \pm 20% 35V	
CB1	DCB-GS2104X02A-1	CABLE ASSEMBLY	
D1	SDS-LS955	ULTRA-HIGH SPEED SWITCHING DIODE	
J1	JCR-AF010PX02	CONNECTOR	
J2	JCF-BA001JX02-1	CONNECTOR	
L1	LCL-C00010	COIL 180 μ H \pm 10%	
L2	LCL-C00010	COIL 180 μ H \pm 10%	
R2	RCP-AN1K	FXD CHIP 1k Ω \pm 0.5% 1/10W	
R3	RCP-AN2R2K	FXD CHIP 2.2k Ω \pm 0.5% 1/10W	
R4	RCP-AN1K	FXD CHIP 1k Ω \pm 0.5% 1/10W	
R5	RCP-AN30K	FXD CHIP 30k Ω \pm 0.5% 1/10W	
R6	RCP-AN10K	FXD CHIP 10k Ω \pm 0.5% 1/10W	
R8	RCP-AN15K	FXD CHIP 15k Ω \pm 0.5% 1/10W	
R9	RCP-AN11K	FXD CHIP 11k Ω \pm 0.5% 1/10W	
R10	RCP-AN110	FXD CHIP 110 Ω \pm 0.5% 1/10W	
R11	RCP-AN1K	FXD CHIP 1k Ω \pm 0.5% 1/10W	
R12	RCP-AN1R8K	FXD CHIP 1.8k Ω \pm 0.5% 1/10W	
R13	RCP-AN3R9K	FXD CHIP 3.9k Ω \pm 0.5% 1/10W	
R14	RCP-AN120	FXD CHIP 120 Ω \pm 0.5% 1/10W	
R15	RCP-AN3R9K	FXD CHIP 3.9k Ω \pm 0.5% 1/10W	
R16	RCP-AN100	FXD CHIP 100 Ω \pm 0.5% 1/10W	
R17	RCP-AN3R9K	FXD CHIP 3.9k Ω \pm 0.5% 1/10W	
R18	RCP-AN82	FXD CHIP 82 Ω \pm 0.5% 1/10W	
R19	RCP-AN3R9K	FXD CHIP 3.9k Ω \pm 0.5% 1/10W	
R20	RCP-AN150	FXD CHIP 150 Ω \pm 0.5% 1/10W	
R21	RCP-AN3R9K	FXD CHIP 3.9k Ω \pm 0.5% 1/10W	
R22	RCP-AN3K	FXD CHIP 3k Ω \pm 0.5% 1/10W	
R23	RCP-AN1K	FXD CHIP 1k Ω \pm 0.5% 1/10W	
U1	SIA-398-2	Monolithic Sample and Hold Circuit	
U2	SIA-TL072CPS	OP AMP DUAL LOW NOISE	
U4	SIA-DG201S	QUAD ANALOG SWITCHES	

R3261/3361
VCO CONT
BLC-015650 (2/2)

Parts No.	Advantest Stock No.	Description	Note
US	SIM-74HC3905	DUAL DECADE COUNTER	

R3261/3361
3RD CONV
BLG-015645 (1/B)

Parts No.	Advantest Stock No.	Description	Note
C1	CCP-BA1000P50V	FXD CHIP 1000PF ±10% 50V	
C2	CCP-BAR01U50V	FXD CHIP 0.01 μ F ±10% 50V	
C4	CCP-BA1P50V	FXD CHIP 1PF ±0.25PF 50V	
C5	CCP-BA7P50V	FXD CHIP 7PF ±0.5PF 50V	
C6	CCP-BA100P50V	FXD CHIP 100PF ±10% 50V	
C7	CCP-BAR01U50V	FXD CHIP 0.01 μ F ±10% 50V	
C12	CCP-BAR01U50V	FXD CHIP 0.01 μ F ±10% 50V	
C14	CCP-BAR01U50V	FXD CHIP 0.01 μ F ±10% 50V	
C15	CCP-BA10P50V	FXD CHIP 10PF ±0.5PF 50V	
C16	CCP-BAR01U50V	FXD CHIP 0.01 μ F ±10% 50V	
C19	CCP-BA2200P50V	FXD CHIP 2200PF ±20% 50V	
C20	CCK-BY22U25V	FXD ELECT 22 μ F ±20% 25V	
C21	CCP-BAR01U50V	FXD CHIP 0.01 μ F ±10% 50V	
C22	CTM-8M8P	VAR 8PF +50%, -2% 100V	
C23	CCP-AT5PR1K	FXD CHIP 5PF ±0.5PF 100V	
C24	CCP-AV220PR1K	FXD CHIP 220PF ±1% 100V	
C25	CCP-8BR1U50V	FXD CHIP 0.1 μ F +80%, -20% 50V	
C26	CCP-AV120PR1K	FXD CHIP 120PF ±2% 100V	
C27	CCP-AT33PR1K	FXD CHIP 33PF ±5% 100V	
C28	CCP-BA1000P50V	FXD CHIP 1000PF ±10% 50V	
C29	CCP-BA1000P50V	FXD CHIP 1000PF ±10% 50V	
C30	CCP-BAR01U50V	FXD CHIP 0.01 μ F ±10% 50V	
C31	CCP-BA1000P50V	FXD CHIP 1000PF ±10% 50V	
C32	CCP-BA1000P50V	FXD CHIP 1000PF ±10% 50V	
C34	CCP-BAR01U50V	FXD CHIP 0.01 μ F ±10% 50V	
C35	CCP-AT15PR1K	FXD CHIP 15PF ±10% 100V	
C37	CCP-BA1000P50V	FXD CHIP 1000PF ±10% 50V	
C38	CCP-AT10PR1K	FXD CHIP 10PF ±0.5PF 100V	
C39	CCP-BA1000P50V	FXD CHIP 1000PF ±10% 50V	
C40	CCP-BAR01U50V	FXD CHIP 0.01 μ F ±10% 50V	
C41	CCP-AT15PR1K	FXD CHIP 15PF ±10% 100V	
C43	CCP-BA1000P50V	FXD CHIP 1000PF ±10% 50V	
C49	CCP-BA1000P50V	FXD CHIP 1000PF ±10% 50V	
C53	CCP-BA10P50V	FXD CHIP 10PF ±0.5PF 50V	
C54	CCP-BA1000P50V	FXD CHIP 1000PF ±10% 50V	
C55	CCP-AT15PR1K	FXD CHIP 15PF ±10% 100V	
C57	CCP-BAR01U50V	FXD CHIP 0.01 μ F ±10% 50V	
C59	CCP-BA33P50V	FXD CHIP 33PF ±5% 50V	
C60	CCP-BA5P50V	FXD CHIP 5PF ±0.5PF 50V	
C61	CCP-BA2P50V	FXD CHIP 2PF ±0.25PF 50V	

R3261/3361
3RD CONV
BLG-015645 (2/8)

Parts No.	Advantest Stock No.	Description				Note	
C62	CCP-BA33P50V	FXD	CHIP	33PF	±5%	50V	
C63	CCP-BA10P50V	FXD	CHIP	10PF	±0.5PF	50V	
C64	CCP-BA3P50V	FXD	CHIP	3PF	±0.25PF	50V	
C65	CTM-BM10P	VAR		10PF	+80%, -%	100V	
C68	CCP-BA33P50V	FXD	CHIP	33PF	±5%	50V	
C67	CCP-BA10P50V	FXD	CHIP	10PF	±0.5PF	50V	
C68	CCP-BA33P50V	FXD	CHIP	33PF	±5%	50V	
C69	CCP-BA5P50V	FXD	CHIP	5PF	±0.5PF	50V	
C70	CCP-BA1000P50V	FXD	CHIP	1000PF	±10%	50V	
C71	CCP-BA2P50V	FXD	CHIP	2PF	±0.25PF	50V	
C72	CCK-BX22U25V	FXD	ELECT	22 μ F	±20%	25V	
C74	CCK-BX22U25V	FXD	ELECT	22 μ F	±20%	25V	
C75	CCP-BAR01U50V	FXD	CHIP	0.01 μ F	±10%	50V	
C76	CCP-BAR01U50V	FXD	CHIP	0.01 μ F	±10%	50V	
C77	CCP-BAR01U50V	FXD	CHIP	0.01 μ F	±10%	50V	
C78	CCP-BAR01U50V	FXD	CHIP	0.01 μ F	±10%	50V	
C80	CCP-BAR01U50V	FXD	CHIP	0.01 μ F	±10%	50V	
C83	CCP-BA1000P50V	FXD	CHIP	1000PF	±10%	50V	
C84	CCP-BAR01U50V	FXD	CHIP	0.01 μ F	±10%	50V	
C85	CCP-BA1000P50V	FXD	CHIP	1000PF	±10%	50V	
C86	CCP-BAR01U50V	FXD	CHIP	0.01 μ F	±10%	50V	
C90	CCP-BAR01U50V	FXD	CHIP	0.01 μ F	±10%	50V	
C92	CCP-BAR01U50V	FXD	CHIP	0.01 μ F	±10%	50V	
C93	CCP-BAR01U50V	FXD	CHIP	0.01 μ F	±10%	50V	
C94	CCP-BA1000P50V	FXD	CHIP	1000PF	±10%	50V	
C95	CCP-BA100P50V	FXD	CHIP	100PF	±10%	50V	
C96	CCP-BAR01U50V	FXD	CHIP	0.01 μ F	±10%	50V	
C100	CCK-BX10U25V	FXD	ELECT	10 μ F	±20%	25V	
C101	CCP-BAR01U50V	FXD	CHIP	0.01 μ F	±10%	50V	
C102	CCP-BA100P50V	FXD	CHIP	100PF	±10%	50V	
C104	CCP-BAR01U50V	FXD	CHIP	0.01 μ F	±10%	50V	
C105	CCP-BAR01U50V	FXD	CHIP	0.01 μ F	±10%	50V	
C106	CCP-BA100P50V	FXD	CHIP	100PF	±10%	50V	
C107	CCP-BAR01U50V	FXD	CHIP	0.01 μ F	±10%	50V	
C114	CSM-AH2R2U50V	FXD	CER	2.2 μ F	+80%, -20%	50V	
C115	CCP-BAR01U50V	FXD	CHIP	0.01 μ F	±10%	50V	
C117	CCK-BX22U25V	FXD	ELECT	22 μ F	±20%	25V	
C119	CCK-BY330U10V	FXD	ELECT	330 μ F	±20%	10V	
C120	CCP-BBR1U50V	FXD	CHIP	0.1 μ F	+80%, -20%	50V	
C122	CCP-BA1000P50V	FXD	CHIP	1000PF	±10%	50V	

R3261/3361
3RD CONV
BLG-015645 (3/8)

Parts No.	Advantest Stock No.	Description	Note
C123	CCP-BA1000P50V	FXD CHIP 1000PF ± 10% 50V	
C125	CCK-BX100U25V	FXD ELECT 100 μ F ± 20% 25V	
C126	CCK-BX100U25V	FXD ELECT 100 μ F ± 20% 25V	
C127	CCK-BX100U10V	FXD ELECT 100 μ F ± 20% 10V	
C128	CTA-AC3R3U16V	FXD TA 3.3 μ F ± 20% 16V	
C129	CTA-AC3R3U16V	FXD TA 3.3 μ F ± 20% 16V	
C130	CCP-BBR1U50V	FXD CHIP 0.1 μ F +80%, -20% 50V	
C131	CCK-BY330U10V	FXD ELECT 330 μ F ± 20% 10V	
C132	CCP-BBR1U50V	FXD CHIP 0.1 μ F +80%, -20% 50V	
C135	CFM-AHR68U100V	FXD FILM 0.68 μ F ± 10% 100V	
C136	CFM-ASR022U50V	FXD FILM 0.022 μ F ± 10% 50V	
C137	CCP-BBR1U50V	FXD CHIP 0.1 μ F +80%, -20% 50V	
C138	CCP-BBR1U50V	FXD CHIP 0.1 μ F +80%, -20% 50V	
C140	CCP-BA15P50V	FXD CHIP 15PF ± 5% 50V	
C152	CCP-AW470PR1K	FXD CHIP 470PF ± 1% 100V	
C153	CCP-AV120PR1K	FXD CHIP 120PF ± 2% 100V	
D1	SDS-1S34	SI PIN DIODE	
D2	SDS-1S2206-2	BURR CAP DIODE	
D3	SDS-LS955	ULTRA-HIGH SPEED SWITCHING DIODE	
D6	SDS-1S887	SI SCHOTTKY DIODE UHF MIXER	
D15	SDS-LS955	ULTRA-HIGH SPEED SWITCHING DIODE	
E1	YEE-000265	SHORT CONNECTOR	
FB1	DEE-001484	FERRITE CORE	
FB3	ESM-000129	FERRITE CORE	
FB4	DEE-001484	FERRITE CORE	
FB10	ESM-000129	FERRITE CORE	
FL1	DNF-000835	D.P.F 400MHz	
J1	JCP-AA003PX05	CONNECTOR	
J4	JCF-BA001.JX01	CONNECTOR	
J7	JCP-AA003PX05	CONNECTOR	
J8	JCF-BA001.JX01	CONNECTOR	
J10	JCF-BA001.JX01	CONNECTOR	
J11	JCF-BA001.JX01	CONNECTOR	
L1	LCL-E00940	COIL CHIP 100nH ± 10%	
L2	LCL-E00338	COIL (CUSTOM DEVICE)	
L3	LCL-E00936	COIL CHIP 47nH ± 20%	
L4	LCL-E00942	COIL CHIP 150nH ± 10%	
L6	LCL-E00960	COIL CHIP 4.7 μ H ± 20%	
L7	LCL-E00960	COIL CHIP 4.7 μ H ± 20%	
L8	LCL-C00102	COIL (CUSTOM DEVICE)	

R3261/3361
3RD CONV
BLG-015645 (4/8)

Parts No.	Advantest Stock No.	Description	Note
L8	LCL-E00388	COIL (CUSTOM DEVICE)	
L10	LCL-A00063	COIL (CUSTOM DEVICE)	
L11	LCL-E00853	COIL CHIP 1.2 μ H \pm 20%	
L13	LCL-A00065	COIL (CUSTOM DEVICE)	
L14	LCL-A00064	COIL (CUSTOM DEVICE)	
L16	LCL-E00389	COIL (CUSTOM DEVICE)	
L18	LCL-E00937	COIL CHIP 5.8nH \pm 20%	
L23	LCL-E00389	COIL (CUSTOM DEVICE)	
L25	LCL-E00937	COIL CHIP 5.8nH \pm 20%	
L26	LCL-A00066	COIL (CUSTOM DEVICE)	
L27	LCL-C01049	COIL (CUSTOM DEVICE)	
L31	LCL-A00066	COIL (CUSTOM DEVICE)	
L32	LCL-C00010	COIL 180 μ H \pm 10%	
L35	LCL-E00389	COIL (CUSTOM DEVICE)	
L36	LCL-C00329	COIL (CUSTOM DEVICE)	
L40	LCL-C00010	COIL 180 μ H \pm 10%	
L42	LCL-E00948	COIL CHIP 0.38 μ H \pm 20%	
L45	LCL-E00484	COIL (CUSTOM DEVICE)	
L46	LCL-E00389	COIL (CUSTOM DEVICE)	
M1	DEE-000735	DOUBLE BALANCE MIXER	
Q1	STN-25C3356	TRANSISTOR NPN	
Q4	STN-25C2757	TRANSISTOR NPN	
Q6	STP-25A812	TRANSISTOR PNP	
Q7	STN-25C3356	TRANSISTOR NPN	
Q8	STN-25C3356	TRANSISTOR NPN	
Q13	STN-25C2757	TRANSISTOR NPN	
Q21	STN-25C1254	TRANSISTOR NPN	
Q22	STP-25A711	TRANSISTOR PNP	
Q24	STN-25C1254	TRANSISTOR NPN	
Q25	STN-25C1959	TRANSISTOR NPN	
Q30	STN-25C1254	TRANSISTOR NPN	
Q31	STP-25A711	TRANSISTOR PNP	
Q33	STN-25C1254	TRANSISTOR NPN	
Q34	STN-25C1050	TRANSISTOR NPN	
R1	RCP-AJ10K	FXD CHIP 10k Ω \pm 5% 1/10W	
R2	RCP-AJ3R3K	FXD CHIP 3.3k Ω \pm 5% 1/10W	
R3	RCP-AJ33	FXD CHIP 33 Ω \pm 5% 1/10W	
R4	RCP-AH220	FXD CHIP 220 Ω \pm 5% 1/8W	
R5	RCP-AJ33	FXD CHIP 33 Ω \pm 5% 1/10W	
R6	RCP-AH330	FXD CHIP 330 Ω \pm 5% 1/8W	

R3261/3361
3RD CONV
BLG-015645 (5/8)

Parts No.	Advantest Stock No.	Description					Note
R7	RCP-AJ56	FXD	CHIP	56 Ω	$\pm 5\%$	1/10W	
R17	RCP-AJ10K	FXD	CHIP	10k Ω	$\pm 5\%$	1/10W	
R18	RCP-AJ5R6K	FXD	CHIP	5.6k Ω	$\pm 5\%$	1/10W	
R19	RCP-AJ33	FXD	CHIP	33 Ω	$\pm 5\%$	1/10W	
R20	REE-AT422S47	METAL	FLM	4200ppm/C	47 Ω	1/8W	
R21	RCP-AJ220	FXD	CHIP	220 Ω	$\pm 5\%$	1/10W	
R22	RCP-AJ10K	FXD	CHIP	10k Ω	$\pm 5\%$	1/10W	
R23	RCP-AJ5R6K	FXD	CHIP	5.6k Ω	$\pm 5\%$	1/10W	
R24	RCP-AJ33	FXD	CHIP	33 Ω	$\pm 5\%$	1/10W	
R25	RCP-AJ220	FXD	CHIP	220 Ω	$\pm 5\%$	1/10W	
R26	RCP-AH880	FXD	CHIP	880 Ω	$\pm 5\%$	1/8W	
R28	RVR-DF20	VAR		20 Ω	$\pm 20\%$	1/2W	
R29	RCP-AJ4R7K	FXD	CHIP	4.7k Ω	$\pm 5\%$	1/10W	
R30	RCP-AJ3R3K	FXD	CHIP	3.3k Ω	$\pm 5\%$	1/10W	
R31	RCP-AJ560	FXD	CHIP	560 Ω	$\pm 5\%$	1/10W	
R32	RCP-AJ470	FXD	CHIP	470 Ω	$\pm 5\%$	1/10W	
R33	RCP-AJ150	FXD	CHIP	150 Ω	$\pm 5\%$	1/10W	
R35	RCP-AJ100	FXD	CHIP	100 Ω	$\pm 5\%$	1/10W	
R36	RCP-AJ4R7K	FXD	CHIP	4.7k Ω	$\pm 5\%$	1/10W	
R37	RCP-AJ4R7K	FXD	CHIP	4.7k Ω	$\pm 5\%$	1/10W	
R38	RCP-AJ880	FXD	CHIP	880 Ω	$\pm 5\%$	1/10W	
R41	RCP-AJ150	FXD	CHIP	150 Ω	$\pm 5\%$	1/10W	
R42	RCP-AJ39	FXD	CHIP	39 Ω	$\pm 5\%$	1/10W	
R43	RCP-AJ150	FXD	CHIP	150 Ω	$\pm 5\%$	1/10W	
R44	RCP-AJ5R6K	FXD	CHIP	5.6k Ω	$\pm 5\%$	1/10W	
R45	RCP-AJ3R3K	FXD	CHIP	3.3k Ω	$\pm 5\%$	1/10W	
R46	RCP-AH330	FXD	CHIP	330 Ω	$\pm 5\%$	1/8W	
R47	RCP-AJ150	FXD	CHIP	150 Ω	$\pm 5\%$	1/10W	
R48	RCP-AJ39	FXD	CHIP	39 Ω	$\pm 5\%$	1/10W	
R49	RCP-AJ150	FXD	CHIP	150 Ω	$\pm 5\%$	1/10W	
R50	RCP-AJ3R3K	FXD	CHIP	3.3k Ω	$\pm 5\%$	1/10W	
R51	RCP-AJ5R6K	FXD	CHIP	5.6k Ω	$\pm 5\%$	1/10W	
R52	RCP-AH330	FXD	CHIP	330 Ω	$\pm 5\%$	1/8W	
R53	RCP-AJ150	FXD	CHIP	150 Ω	$\pm 5\%$	1/10W	
R54	RCP-AJ39	FXD	CHIP	39 Ω	$\pm 5\%$	1/10W	
R55	RCP-AJ150	FXD	CHIP	150 Ω	$\pm 5\%$	1/10W	
R56	RCP-AJ470	FXD	CHIP	470 Ω	$\pm 5\%$	1/10W	
R57	RCB-AGSR6	FXD	CAR	5.6 Ω	$\pm 5\%$	1/8W	
R60	RCP-AJ22	FXD	CHIP	22 Ω	$\pm 5\%$	1/10W	
R61	RCP-AJ10	FXD	CHIP	10 Ω	$\pm 5\%$	1/10W	

R3261/3361
3RD CONV
BLG-015645 (68)

Parts No.	Advantest Stock No.	Description	Note
R62	RCP-AJ10	FXD CHIP 10Ω ±5% 1/10W	
R69	RCP-AJ330	FXD CHIP 330Ω ±5% 1/10W	
R70	RCP-AJ22	FXD CHIP 22Ω ±5% 1/10W	
R71	RCP-AJ330	FXD CHIP 330Ω ±5% 1/10W	
R72	RCP-AJ22	FXD CHIP 22Ω ±5% 1/10W	
R73	RCP-AJ330	FXD CHIP 330Ω ±5% 1/10W	
R74	RCP-AJ22	FXD CHIP 22Ω ±5% 1/10W	
R75	RCP-AJ330	FXD CHIP 330Ω ±5% 1/10W	
R76	RCP-AJ3R3K	FXD CHIP 3.3kΩ ±5% 1/10W	
R77	RCP-AJ5R8K	FXD CHIP 5.6kΩ ±5% 1/10W	
R78	RCP-AH330	FXD CHIP 330Ω ±5% 1/8W	
R79	RCP-AJ330	FXD CHIP 330Ω ±5% 1/10W	
R80	RCP-AJ22	FXD CHIP 22Ω ±5% 1/10W	
R81	RCP-AJ330	FXD CHIP 330Ω ±5% 1/10W	
R82	RCP-AH510	FXD CHIP 510Ω ±5% 1/8W	
R83	RCP-AJ22	FXD CHIP 22Ω ±5% 1/10W	
R85	RCP-AJ220	FXD CHIP 220Ω ±5% 1/10W	
R86	RCP-AJ22	FXD CHIP 22Ω ±5% 1/10W	
R87	RCP-AJ220	FXD CHIP 220Ω ±5% 1/10W	
R88	RCP-AJ100	FXD CHIP 100Ω ±5% 1/10W	
R90	RCP-AJ10K	FXD CHIP 10kΩ ±5% 1/10W	
R93	RCP-AJ22	FXD CHIP 22Ω ±5% 1/10W	
R94	RCP-AH1K	FXD CHIP 1kΩ ±5% 1/8W	
R95	RCP-AJ68	FXD CHIP 68Ω ±5% 1/10W	
R97	RCP-AJ22	FXD CHIP 22Ω ±5% 1/10W	
R98	RCP-AJ330	FXD CHIP 330Ω ±5% 1/10W	
R99	RCP-AH330	FXD CHIP 330Ω ±5% 1/8W	
R100	RCP-AH1R2K	FXD CHIP 1.2kΩ ±5% 1/8W	
R102	RCP-AJ1K	FXD CHIP 1kΩ ±5% 1/10W	
R103	RCP-AJ470	FXD CHIP 470Ω ±5% 1/10W	
R105	RCP-AJ1K	FXD CHIP 1kΩ ±5% 1/10W	
R106	RCP-AJ680	FXD CHIP 680Ω ±5% 1/10W	
R107	RCP-AJ22	FXD CHIP 22Ω ±5% 1/10W	
R109	RCP-AH2R2K	FXD CHIP 2.2kΩ ±5% 1/8W	
R110	RCP-AJ1K	FXD CHIP 1kΩ ±5% 1/10W	
R111	RCP-AJ51	FXD CHIP 51Ω ±5% 1/10W	
R112	RCP-AJ680	FXD CHIP 680Ω ±5% 1/10W	
R113	RCP-AJ33	FXD CHIP 33Ω ±5% 1/10W	
R115	RCP-AH2R2K	FXD CHIP 2.2kΩ ±5% 1/8W	
R116	RCP-AJ150	FXD CHIP 150Ω ±5% 1/10W	

R3261/3361
3RD CONV
BLG-016646 (7/8)

Parts No.	Advantest Stock No.	Description	Note
R117	RCP-AJ51	FXD CHIP 51 Ω \pm 5% 1/10W	
R118	RCP-AJ5R6K	FXD CHIP 5.6k Ω \pm 5% 1/10W	
R119	RCP-AJ10K	FXD CHIP 10k Ω \pm 5% 1/10W	
R120	RCP-AJ33	FXD CHIP 33 Ω \pm 5% 1/10W	
R121	RCP-AJ1K	FXD CHIP 1k Ω \pm 5% 1/10W	
R122	RCP-AJ22	FXD CHIP 22 Ω \pm 5% 1/10W	
R123	RCP-AH470	FXD CHIP 470 Ω \pm 5% 1/8W	
R124	RCP-AN2R2K	FXD CHIP 2.2k Ω \pm 0.5% 1/10W	
R126	RCP-AN1K	FXD CHIP 1k Ω \pm 0.5% 1/10W	
R128	RCP-AN18K	FXD CHIP 18k Ω \pm 0.5% 1/10W	
R130	RCP-AN1K	FXD CHIP 1k Ω \pm 0.5% 1/10W	
R131	RCP-AN100	FXD CHIP 100 Ω \pm 0.5% 1/10W	
R133	RCP-AN5R6K	FXD CHIP 5.6k Ω \pm 0.5% 1/10W	
R134	RCP-AJ4R7K	FXD CHIP 4.7k Ω \pm 5% 1/10W	
R135	RCP-AJ4R7K	FXD CHIP 4.7k Ω \pm 5% 1/10W	
R136	RCB-AG1R8K	FXD CAR 1.8k Ω \pm 5% 1/6W	
R137	RCP-AJ1R2K	FXD CHIP 1.2k Ω \pm 5% 1/10W	
R138	RVR-DF2K	VAR 2k Ω \pm 20% 1/2W	
R140	RCP-AJ1K	FXD CHIP 1k Ω \pm 5% 1/10W	
R141	RCP-AJ470	FXD CHIP 470 Ω \pm 5% 1/10W	
R142	RCP-AJ470	FXD CHIP 470 Ω \pm 5% 1/10W	
R143	RCP-AJ51	FXD CHIP 51 Ω \pm 5% 1/10W	
R145	RCP-AN750	FXD CHIP 750 Ω \pm 0.5% 1/10W	
R146	RCP-AN750	FXD CHIP 750 Ω \pm 0.5% 1/10W	
R147	RCP-AN560	FXD CHIP 560 Ω \pm 0.5% 1/10W	
R148	RCP-AN1K	FXD CHIP 1k Ω \pm 0.5% 1/10W	
R149	RCP-AN560	FXD CHIP 560 Ω \pm 0.5% 1/10W	
R150	RCP-AN1K	FXD CHIP 1k Ω \pm 0.5% 1/10W	
R151	RCP-AN8R2K	FXD CHIP 8.2k Ω \pm 0.5% 1/10W	
R152	RCP-AN2R7K	FXD CHIP 2.7k Ω \pm 0.5% 1/10W	
R153	RCP-AJ1R8K	FXD CHIP 1.8k Ω \pm 5% 1/10W	
R154	RCP-AJ1K	FXD CHIP 1k Ω \pm 5% 1/10W	
R155	RVR-DF2K	VAR 2k Ω \pm 20% 1/2W	
R156	RCB-AG47	FXD CAR 47 Ω \pm 5% 1/8W	
TP1	MBM-10372A-1	TEST PIN	
TP3	MBM-10372A-1	TEST PIN	
U1	SIM-74HC04S	HEX INVERTER	
U2	SIA-187B	Bipolar Analog IC 1GHz Amp	
U3	SIC-12013	DUAL MODULUS PRESCALER	
U4	SIT-74LS74S	DUAL D-TYPE FLIP-FLOP	

R3261/3361
 3RD CONV
 BLG-015645 (8/8)

Parts No.	Advantest Stock No.	Description	Note
U5	SIT-74LS112S	DUAL J-K FLIP-FLOP	
U7	SIT-74LS00S	QUAD 2-INPUT NAND	
U9	SIM-74HC04S	HEX INVERTER	
U10	SIA-167S	Bipolar Analog IC 1GHz Amp	
U11	SIC-MC12009P	1/8 PRESCALER	
U16	SIT-74S112S-1	DUAL J-K FLIP-FLOP	
U17	SIT-74S00S-1	QUAD 2-INPUT NAND	
U18	SIA-OP07PS	OP AMP ULTRA-LOW OFFSET	
X1	DXD-001121-1	CRYSTAL	

R3261/3361
YTO SYNTHÉ
BLK-015649 (1/8)

Parts No.	Advantest Stock No.	Description			Note	
C1	CCP-BA100P50V	FXD	CHIP	100PF ±10%	50V	
C2	CCP-BBR1U50V	FXD	CHIP	0.1 μ F +80%, -20%	50V	
C3	CCP-BA1000P50V	FXD	CHIP	1000PF ±10%	50V	
C4	CCP-AT7PR1K	FXD	CHIP	7PF ±0.5PF	100V	
C5	CCP-AT10PR1K	FXD	CHIP	10PF ±1PF	100V	
C7	CCP-BAR01U50V	FXD	CHIP	0.01 μ F ±10%	50V	
C8	CTM-BM30P	VAR		30PF +50%, -0%	100V	
C10	CTM-BM10P	VAR		10PF +50%, -0%	100V	
C11	CCP-BBR1U50V	FXD	CHIP	0.1 μ F +80%, -20%	50V	
C14	CCP-SA33P50V	FXD	CHIP	33PF ±5%	50V	
C15	CCP-BBR1U50V	FXD	CHIP	0.1 μ F +80%, -20%	50V	
C16	CCP-BA68P50V	FXD	CHIP	68PF ±5%	50V	
C17	CCP-AV47PR1K	FXD	CHIP	47PF ±2%	100V	
C18	CCP-AV51PR1K	FXD	CHIP	51PF ±2%	100V	
C19	CCP-AV47PR1K	FXD	CHIP	47PF ±2%	100V	
C20	CCP-BAR01U50V	FXD	CHIP	0.01 μ F ±10%	50V	
C21	CCP-BBR1U50V	FXD	CHIP	0.1 μ F +80%, -20%	50V	
C22	CCP-BAR01U50V	FXD	CHIP	0.01 μ F ±10%	50V	
C23	CCP-BBR1U50V	FXD	CHIP	0.1 μ F +80%, -20%	50V	
C24	CCP-BAR01U50V	FXD	CHIP	0.01 μ F ±10%	50V	
C25	CCP-BA470P50V	FXD	CHIP	470PF ±5%	50V	
C26	CCP-BBR1U50V	FXD	CHIP	0.1 μ F +80%, -20%	50V	
C29	CFM-AS4700P50V	FXD	FILM	4700PF ±10%	50V	
C30	CCP-BA1000P50V	FXD	CHIP	1000PF ±10%	50V	
C31	CCP-AT11PR1K	FXD	CHIP	11PF ±10%	100V	
C33	CCP-AT3PR1K	FXD	CHIP	3PF ±0.5PF	100V	
C34	CCP-AT5PR1K	FXD	CHIP	5PF ±0.5PF	100V	
C35	CCP-AT7PR1K	FXD	CHIP	7PF ±0.5PF	100V	
C36	CCP-BA33P50V	FXD	CHIP	33PF ±5%	50V	
C37	CCP-BA5P50V	FXD	CHIP	5PF ±0.5PF	50V	
C38	CCP-BA1000P50V	FXD	CHIP	1000PF ±10%	50V	
C39	CCK-BX47U25V	FXD	ELECT	47 μ F ±20%	25V	
C40	CCP-BBR1U50V	FXD	CHIP	0.1 μ F +80%, -20%	50V	
C41	CCP-BA1000P50V	FXD	CHIP	1000PF ±10%	50V	
C42	CCK-BX100U10V	FXD	ELECT	100 μ F ±20%	10V	
C43	CCK-BX100U25V	FXD	ELECT	100 μ F ±20%	25V	
C44	CSM-AGR01U50V	FXD	CER	0.01 μ F +80%, -20%	50V	
C45	CCP-BA100P50V	FXD	CHIP	100PF ±10%	50V	
C46	CCP-BAR01U50V	FXD	CHIP	0.01 μ F ±10%	50V	
C48	CCP-BAR01U50V	FXD	CHIP	0.01 μ F ±10%	50V	

R3261/3361
 YTO SYNTHÉ
 BLK-015649 (2/8)

Parts No.	Advantest Stock No.	Description			Note	
C49	CCP-BAR01U50V	FXD	CHIP	0.01 μ F \pm 10%	50V	
C50	CCP-BBR1U50V	FXD	CHIP	0.1 μ F +80%,-20%	50V	
C51	CCK-BX100U10V	FXD	ELECT	100 μ F \pm 20%	10V	
C52	CTA-AC3R3U18V	FXD	TA	3.3 μ F \pm 20%	18V	
C53	CCK-BX100U10V	FXD	ELECT	100 μ F \pm 20%	10V	
C54	CCK-BX47U25V	FXD	ELECT	47 μ F \pm 20%	25V	
C55	CCK-BX47U25V	FXD	ELECT	47 μ F \pm 20%	25V	
C56	CFM-ASF901U80V	FXD	FILM	0.01 μ F \pm 10%	50V	
C57	CFM-AHR1U100V	FXD	FILM	0.1 μ F \pm 10%	100V	
C58	CCP-AV47PR1K	FXD	CHIP	47PF \pm 2%	100V	
C59	CCP-AV51PR1K	FXD	CHIP	51PF \pm 2%	100V	
C60	CCP-AV47PR1K	FXD	CHIP	47PF \pm 2%	100V	
C61	CCP-BAR01U50V	FXD	CHIP	0.01 μ F \pm 10%	50V	
C62	CCP-BBR1U50V	FXD	CHIP	0.1 μ F +80%,-20%	50V	
C66	CTA-AA100U20V	FXD	TA	100 μ F \pm 20%	20V	
C67	CTA-AA100U20V	FXD	TA	100 μ F \pm 20%	20V	
C68	CCP-BBR1U50V	FXD	CHIP	0.1 μ F +80%,-20%	50V	
C70	CFM-AH1U100V	FXD	FILM	1 μ F \pm 10%	100V	
C74	CCP-BBR1U50V	FXD	CHIP	0.1 μ F +80%,-20%	50V	
C75	CCP-BAR01U50V	FXD	CHIP	0.01 μ F \pm 10%	50V	
C76	CCP-BBR1U50V	FXD	CHIP	0.1 μ F +80%,-20%	50V	
C77	CCP-BBR1U50V	FXD	CHIP	0.1 μ F +80%,-20%	50V	
C78	CCP-BA3P50V	FXD	CHIP	3PF \pm 0.25PF	50V	
C79	CCP-BA3P50V	FXD	CHIP	3PF \pm 0.25PF	50V	
C80	CCP-AT18PR1K	FXD	CHIP	18PF \pm 10%	100V	
C81	CCP-BA15P50V	FXD	CHIP	15PF \pm 5%	50V	
C82	CCP-BA1P50V	FXD	CHIP	1PF \pm 0.25PF	50V	
C83	CCP-BA15P50V	FXD	CHIP	15PF \pm 5%	50V	
C85	CFM-AS1000P50V	FXD	FILM	1000PF \pm 10%	50V	
C86	CFM-ANR1U50V	FXD	FILM	0.1 μ F \pm 5%	50V	
C87	CCP-BA10P50V	FXD	CHIP	10PF \pm 0.5%	50V	
C88	CCP-BA470P50V	FXD	CHIP	470PF \pm 5%	50V	
C89	CCP-BA1000P50V	FXD	CHIP	1000PF \pm 10%	50V	
C90	CCP-BA100P50V	FXD	CHIP	100PF \pm 10%	50V	
C91	CCP-AT7PR1K	FXD	CHIP	7PF \pm 0.5PF	100V	
C92	CCP-AT10PR1K	FXD	CHIP	10PF \pm 1PF	100V	
C93	CCP-AT2R5PR1K	FXD	CHIP	2.5PF \pm 0.25PF	100V	
C94	CCP-AT10PR1K	FXD	CHIP	10PF \pm 1PF	100V	
C95	CCP-AT7PR1K	FXD	CHIP	7PF \pm 0.5PF	100V	
C96	CCP-BA33P50V	FXD	CHIP	33PF \pm 5%	50V	

R3261/3361
 YTO SYNTHÉ
 BLK-015649 (3/8)

Parts No.	Advantest Stock No.	Description	Note
C97	CCP-BA5P50V	FXD CHIP 5PF $\pm 0.5PF$ 50V	
C98	CCP-BA1000P50V	FXD CHIP 1000PF $\pm 10\%$ 50V	
C99	CCK-BX47U25V	FXD ELECT 47 μF $\pm 20\%$ 25V	
C100	CCP-BBR1U50V	FXD CHIP 0.1 μF $+80\%$, -20% 50V	
C101	CCP-BA1000P50V	FXD CHIP 1000PF $\pm 10\%$ 50V	
C102	CCP-BBR1U50V	FXD CHIP 0.1 μF $+80\%$, -20% 50V	
C104	CCP-BBR1U50V	FXD CHIP 0.1 μF $+80\%$, -20% 50V	
C105	CCK-BX100U10V	FXD ELECT 100 μF $\pm 20\%$ 10V	
C106	CCK-BX100U10V	FXD ELECT 100 μF $\pm 20\%$ 10V	
C107	CCK-BX100U10V	FXD ELECT 100 μF $\pm 20\%$ 10V	
C108	CCK-BX100U10V	FXD ELECT 100 μF $\pm 20\%$ 10V	
C109	CCK-BX47U25V	FXD ELECT 47 μF $\pm 20\%$ 25V	
C110	CCK-BX47U25V	FXD ELECT 47 μF $\pm 20\%$ 25V	
C111	CCP-BA1000P50V	FXD CHIP 1000PF $\pm 10\%$ 50V	
C112	CCP-BA1000P50V	FXD CHIP 1000PF $\pm 10\%$ 50V	
C113	CCP-BA1000P50V	FXD CHIP 1000PF $\pm 10\%$ 50V	
C114	CCP-BAR01U50V	FXD CHIP 0.01 μF $\pm 10\%$ 50V	
C115	CCP-BBR1U50V	FXD CHIP 0.1 μF $+80\%$, -20% 50V	
C116	CCP-BA1000P50V	FXD CHIP 1000PF $\pm 10\%$ 50V	
C118	CCK-BX100U10V	FXD ELECT 100 μF $\pm 20\%$ 10V	
C119	CCP-BA100P50V	FXD CHIP 100PF $\pm 10\%$ 50V	
C120	CCK-BX47U25V	FXD ELECT 47 μF $\pm 20\%$ 25V	
C121	CCK-BX47U25V	FXD ELECT 47 μF $\pm 20\%$ 25V	
C122	CCK-BX330U10V	FXD ELECT 330 μF $\pm 20\%$ 10V	
C123	CTA-AC3R3U16V	FXD TA 3.3 μF $\pm 20\%$ 16V	
C124	CCP-BA1000P50V	FXD CHIP 1000PF $\pm 10\%$ 50V	
C125	CCP-BA1000P50V	FXD CHIP 1000PF $\pm 10\%$ 50V	
C126	CCP-BA27P50V	FXD CHIP 27PF $\pm 5\%$ 50V	
C127	CCP-BBR1U50V	FXD CHIP 0.1 μF $+80\%$, -20% 50V	
C128	CCP-BA100P50V	FXD CHIP 100PF $\pm 10\%$ 50V	
C129	CCP-BA10P50V	FXD CHIP 10PF $\pm 0.5\%$ 50V	
C130	CCP-BA18P50V	FXD CHIP 18PF $\pm 10\%$ 50V	
C131	CSM-BA220P50V	FXD CER 220PF $\pm 5\%$ 50V	
C132	CCP-BA100P50V	FXD CHIP 100PF $\pm 10\%$ 50V	
C133	CCP-BA4P50V	FXD CHIP 4PF $\pm 0.5PF$ 50V	
C134	CCP-BA100P50V	FXD CHIP 100PF $\pm 10\%$ 50V	
C135	CCP-BA100P50V	FXD CHIP 100PF $\pm 10\%$ 50V	
C136	CTM-BM20P	VAR 20PF $+50\%$, -0% 100V	
C137	CCP-BA2P50V	FXD CHIP 2PF $\pm 0.25PF$ 50V	
C138	CCP-BAR01U50V	FXD CHIP 0.01 μF $\pm 10\%$ 50V	

R3261/3361
 YTO SYNTHÉ
 BLK-015649 (4/8)

Parts No.	Advantest Stock No.	Description	Note
C139	CCP-TCR1U50V	FXD CHIP 0.1 μ F +80% -25% 50V	
C140	CSM-AGR01U50V	FXD CER 0.01 μ F +80% -25% 50V	
C141	CCP-BA150P50V	FXD CER 150PF \pm 5% 50V	
C142	CCP-BA10P50V	FXD CER 10PF \pm 0.5PF 50V	
C143	CCP-BA10P50V	FXD CER 10PF \pm 0.5PF 50V	
C144	CCK-BY100U25V	FXD ELECT 100 μ F \pm 20% 25V	
C145	CTA-AE2R2U20V	FXD TA 2.2 μ F \pm 20% 20V	
C150	CCP-BA100P50V	FXD CHIP 100PF \pm 10% 50V	
D2	SDZ-M051	ZENER DIODE	
D3	SDS-LS955	ULTRA-HIGH SPEED SWITCHING DIODE	
D5	SDS-LD1	SI SWITCHING DIODE	
D6	SDS-1S2206	BURR CAP DIODE MIXER	
D7	SDS-1SS242	SI SCHOTTKY BARRIER DIODE UHF	
D10	SDS-L9955	ULTRA-HIGH SPEED SWITCHING DIODE	
D20	SDS-LS955	ULTRA-HIGH SPEED SWITCHING DIODE	
D21	SDS-1S2206	BURR CAP DIODE MIXER	
D22	SDS-1SS242	SI SCHOTTKY BARRIER DIODE UHF	
D24	SDS-L9955	ULTRA-HIGH SPEED SWITCHING DIODE	
DR1	DEE-001877-1	DR 400MHz	
DR2	DEE-001878-1	DR 350MHz	
FB1	ESM-000129	FERRITE CURE	
FB3	ESM-000129	FERRITE CURE	
J1	JCR-A/010PX02	CONNECTOR	
J2	JCF-BA001JX01-1	CONNECTOR	
J3	JCS-B2003PX01	CONNECTOR	
J4	JCF-BA001JX01	CONNECTOR	
L1	LCL-E01296-1	COIL CHIP 56nH \pm 5%	
L2	LCL-A00062	COIL (CUSTOM DEVICE)	
L3	LCL-E00952	COIL CHIP 1 μ H \pm 20%	
L4	LCL-E00947	COIL CHIP 0.27 μ H \pm 20%	
L5	LCL-E00948	COIL CHIP 0.39 μ H \pm 20%	
L7	LCL-E00947	COIL CHIP 0.27 μ H \pm 20%	
L8	LCL-E00948	COIL CHIP 0.39 μ H \pm 20%	
L9	LCL-E00354	COIL 2200 μ H \pm 10%	
L10	LCL-E00952	COIL CHIP 1 μ H \pm 20%	
L11	LCL-E00952	COIL CHIP 1 μ H \pm 20%	
L12	LCL-E00947	COIL CHIP 0.27 μ H \pm 20%	
L13	LCL-E00948	COIL CHIP 0.39 μ H \pm 20%	
L14	LCL-E00948	COIL CHIP 0.39 μ H \pm 20%	
L15	LCL-E00947	COIL CHIP 0.27 μ H \pm 20%	

R3261/3361
 YTO SYNTHÉ
 BLK-015649 (5/8)

Parts No.	Advantest Stock No.	Description	Note
L16	LCL-E00933	COIL CHIP 22nH ±20%	
L17	LCL-E00933	COIL CHIP 22nH ±20%	
L18	LCL-E00952	COIL CHIP 1.0µH ±20%	
L20	LCL-E00952	COIL CHIP 1.0µH ±20%	
L21	LCL-E00943	COIL CHIP 180nH ±10%	
L22	LCL-C00010	COIL 180µH ±10%	
L23	LCL-C00010	COIL 180µH ±10%	
L25	LCL-C00010	COIL 180µH ±10%	
L28	LCL-E01078	COIL CHIP 33nH ±20%	
L29	LCL-E01072	COIL CHIP 10nH ±20%	
L30	LCL-E01092	COIL CHIP 0.1µH ±5%	
L31	LCL-E01072	COIL CHIP 10nH ±20%	
L32	LCL-E01095	COIL CHIP 0.18µH ±5%	
L33	LCL-E01081	COIL CHIP 0.27µH ±20%	
L34	LCL-E01077	COIL CHIP 27nH ±20%	
MX1	DEE-000736	DOUBLE BALANCE MIXER	
Q1	STN-2SC3356	TRANSISTOR NPN	
Q2	STN-2SC1426	TRANSISTOR NPN	
Q3	SFM-3SK129	MES FET GzAs N Channel	
Q4	STP-2SA1462	TRANSISTOR PNP	
Q5	STN-2SC3356	TRANSISTOR NPN	
Q6	STP-2SA812	TRANSISTOR PNP	
Q7	STN-2SC2712	TRANSISTOR NPN	
Q8	STN-2SC2712	TRANSISTOR NPN	
Q10	STN-2SC1254	TRANSISTOR NPN	
Q11	STP-2SA711	TRANSISTOR PNP	
Q13	STN-2SC1254	TRANSISTOR NPN	
Q14	STN-2SC2712	TRANSISTOR NPN	
Q15	STN-2SC1254	TRANSISTOR NPN	
Q16	STP-2SA711	TRANSISTOR PNP	
Q18	STN-2SC1254	TRANSISTOR NPN	
Q20	STN-2SC3356	TRANSISTOR NPN	
Q21	STP-2SA812	TRANSISTOR PNP	
Q22	STN-2SC2712	TRANSISTOR NPN	
Q23	STN-2SC1059	TRANSISTOR NPN	
R1	RCP-AN100	FXD CHIP 100Ω ±0.5% 1/10W	
R2	RCP-ANSR1K	FXD CHIP 5.1kΩ ±0.5% 1/10W	
R3	RCP-AN10K	FXD CHIP 10kΩ ±0.5% 1/10W	
R4	RCP-AJBR2	FXD CHIP 8.2Ω ±10% 1/10W	
R5	RCP-AN270	FXD CHIP 270Ω ±0.5% 1/10W	

R3261/3361
 YTO SYNTHÉ
 BLK-015649 (6/8)

Parts No.	Advantest Stock No.	Description	Note
R6	RCP-AH180	FXD CHIP 180 μ \pm 5% 1/8W	
R7	RCP-AN100	FXD CHIP 100 μ \pm 0.5% 1/10W	
R8	RCP-AN22	FXD CHIP 22 μ \pm 0.5% 1/10W	
R9	RCP-AH270	FXD CHIP 270 μ \pm 5% 1/8W	
R10	RCP-AH270	FXD CHIP 270 μ \pm 5% 1/8W	
R11	RCP-AH270	FXD CHIP 270 μ \pm 5% 1/8W	
R12	RVR-DF10K	VAR 10k Ω \pm 20% 1/2W	
R13	RCP-AN1K	FXD CHIP 1k Ω \pm 0.5% 1/10W	
R14	RCP-AN10K	FXD CHIP 10k Ω \pm 0.5% 1/10W	
R15	RCP-AN8R2K	FXD CHIP 8.2k Ω \pm 0.5% 1/10W	
R16	RCP-AN3R3K	FXD CHIP 3.3k Ω \pm 0.5% 1/10W	
R17	RCP-AN5R9K	FXD CHIP 5.9k Ω \pm 0.5% 1/10W	
R18	RCP-AN820	FXD CHIP 820 Ω \pm 0.5% 1/10W	
R19	RCP-AN580	FXD CHIP 580 Ω \pm 0.5% 1/10W	
R20	RCP-AN56	FXD CHIP 56 Ω \pm 0.5% 1/10W	
R21	RCP-AN33	FXD CHIP 33 Ω \pm 0.5% 1/10W	
R22	RCP-AN560	FXD CHIP 560 Ω \pm 0.5% 1/10W	
R23	RCP-AN1R8K	FXD CHIP 1.8k Ω \pm 0.5% 1/10W	
R24	RCP-AN22	FXD CHIP 22 Ω \pm 0.5% 1/10W	
R26	RCP-AN270	FXD CHIP 270 Ω \pm 0.5% 1/10W	
R27	RCP-AN18	FXD CHIP 18 Ω \pm 0.5% 1/10W	
R28	RCP-AN270	FXD CHIP 270 Ω \pm 0.5% 1/10W	
R29	RCP-AN15K	FXD CHIP 15k Ω \pm 0.5% 1/10W	
R30	RCP-AN10K	FXD CHIP 10k Ω \pm 0.5% 1/10W	
R31	RCP-AN6R9K	FXD CHIP 6.9k Ω \pm 0.5% 1/10W	
R32	RCP-AN150	FXD CHIP 150 Ω \pm 0.5% 1/10W	
R33	RCP-AN39	FXD CHIP 39 Ω \pm 0.5% 1/10W	
R34	RCP-AN150	FXD CHIP 150 Ω \pm 0.5% 1/10W	
R35	RCP-AN150	FXD CHIP 150 Ω \pm 0.5% 1/10W	
R36	RCP-AN10K	FXD CHIP 10k Ω \pm 0.5% 1/10W	
R37	RCP-AN4R7K	FXD CHIP 4.7k Ω \pm 0.5% 1/10W	
R38	RCP-AN56	FXD CHIP 56 Ω \pm 0.5% 1/10W	
R39	RCP-AN390	FXD CHIP 390 Ω \pm 0.5% 1/10W	
R40	RCP-AN3R3K	FXD CHIP 3.3k Ω \pm 0.5% 1/10W	
R41	RCP-AN2R2K	FXD CHIP 2.2k Ω \pm 0.5% 1/10W	
R42	RCP-AN2R2K	FXD CHIP 2.2k Ω \pm 0.5% 1/10W	
R43	RCP-AN1K	FXD CHIP 1k Ω \pm 0.5% 1/10W	
R45	RCP-AN1K	FXD CHIP 1k Ω \pm 0.5% 1/10W	
R47	RCP-AN18K	FXD CHIP 18k Ω \pm 0.5% 1/10W	
R48	RCP-AN1K	FXD CHIP 1k Ω \pm 0.5% 1/10W	

R3261/3361
 YTO SYNTHETIC
 BLK-015649 (7/8)

Parts No.	Advantest Stock No.	Description	Note
R49	RCP-AN51	FXD CHIP 51n ±0.5% 1/10W	
R50	RCP-AN10K	FXD CHIP 10kn ±0.5% 1/10W	
R51	RCP-AN750	FXD CHIP 750n ±0.5% 1/10W	
R52	RCP-AN750	FXD CHIP 750n ±0.5% 1/10W	
R53	RCP-AN560	FXD CHIP 560n ±0.5% 1/10W	
R54	RCP-AN560	FXD CHIP 560n ±0.5% 1/10W	
R55	RCP-AN1K	FXD CHIP 1kn ±0.5% 1/10W	
R57	RCP-ANBR2K	FXD CHIP 8.2kn ±0.5% 1/10W	
R58	RCP-AN100	FXD CHIP 100n ±0.5% 1/10W	
R59	RCP-AN4R7K	FXD CHIP 4.7kn ±0.5% 1/10W	
R60	RCP-AN4R7K	FXD CHIP 4.7kn ±0.5% 1/10W	
R61	RCP-AN5R9K	FXD CHIP 5.6kn ±0.5% 1/10W	
R62	RCP-AN180	FXD CHIP 180n ±0.5% 1/10W	
R64	RCP-AN12	FXD CHIP 12n ±0.5% 1/10W	
R79	RCP-AN10K	FXD CHIP 10kn ±0.5% 1/10W	
R80	RCP-AN4R7K	FXD CHIP 4.7kn ±0.5% 1/10W	
R81	RCP-AN56	FXD CHIP 56n ±0.5% 1/10W	
R82	RCP-AN390	FXD CHIP 390n ±0.5% 1/10W	
R83	RCP-AN3R3K	FXD CHIP 3.3kn ±0.5% 1/10W	
R84	RCP-AN1K	FXD CHIP 1kn ±0.5% 1/10W	
R85	RCP-AN470	FXD CHIP 470n ±0.5% 1/10W	
R87	RCP-AN150	FXD CHIP 150n ±0.5% 1/10W	
R102	RCP-AN22K	FXD CHIP 22kn ±0.5% 1/10W	
R103	RCP-AN22K	FXD CHIP 22kn ±0.5% 1/10W	
R104	RCP-AN1R5K	FXD CHIP 1.5kn ±0.5% 1/10W	
R105	RCP-AN2R4K	FXD CHIP 2.4kn ±0.5% 1/10W	
R106	RCP-AN1K	FXD CHIP 1kn ±0.5% 1/10W	
R107	RCP-AN100	FXD CHIP 100n ±0.5% 1/10W	
R108	RCP-AN68	FXD CHIP 68n ±0.5% 1/10W	
R109	RCP-AN100	FXD CHIP 100n ±0.5% 1/10W	
R110	RCP-AN68	FXD CHIP 68n ±0.5% 1/10W	
R111	RCP-AN100	FXD CHIP 100n ±0.5% 1/10W	
R112	RCP-AN68	FXD CHIP 68n ±0.5% 1/10W	
R113	RCP-AN51	FXD CHIP 51n ±0.5% 1/10W	
R115	RCP-AN150	FXD CHIP 150n ±0.5% 1/10W	
R116	RCP-AN33	FXD CHIP 33n ±0.5% 1/10W	
R117	RCP-AN150	FXD CHIP 150n ±0.5% 1/10W	
R118	RCP-AN2R7K	FXD CHIP 2.7kn ±0.5% 1/10W	
R119	RCP-AN51	FXD CHIP 51n ±0.5% 1/10W	
R120	RCP-AN1R9K	FXD CHIP 1.8kn ±0.5% 1/10W	

R3261/3361
 YTO SYNTHÉ
 BLK-015649 (8/8)

Parts No.	Advantest Stock No.	Description	Note
R121	RCP-AN1K	FXD CHIP 1k Ω \pm 0.5% 1/10W	
R122	RVR-DF2K	VAR 2k Ω \pm 20% 1/2W	
R123	RCP-AN22	FXD CHIP 22 Ω \pm 0.5% 1/10W	
R124	RCP-AN10	FXD CHIP 10 Ω \pm 0.5% 1/10W	
R125	RCP-AN33	FXD CHIP 33 Ω \pm 0.5% 1/10W	
U1	SIA-1676	Bipolar Analog IC 1GHz Amp	
U2	SIA-373S	COMPARATOR Dual Low Noise Low Offset	
U5	SIA-1675	Bipolar Analog IC 1GHz Amp	
U6	SIC-555	1GHz PRESCALER	
U7	SIA-1675	Bipolar Analog IC 1GHz Amp	
U8	SIA-1676	Bipolar Analog IC 1GHz Amp	
U10	SIC-555	LOW POWER 2-MODULUS PRESCALER	
U11	SIM-145146	4-BIT DATA BUS INPUT PLL FREQ SYNTHÉ	
U12	SIT-74S112-1	DUAL J-K FLIP-FLOP	
U13	SIT-74S00S-1	QUAD 2-INPUT NAND	
U14	SIT-74HC04S	HEX INVERTER	
U15	SIA-1676	Bipolar Analog IC 1GHz Amp	
U16	SIT-74F74S	DUAL D-TYPE FLIP-FLOP	
U17	SIT-74F112S	DUAL J-K FLIP-FLOP	
U18	SIT-74F00S	QUAD 2-INPUT NAND	
U19	SIA-386	MONOLITHIS SAMPLE AND HOLD CIRCUITS	
U24	SIA-1675	Bipolar Analog IC 1GHz Amp	
U25	SIC-12013	DUAL MODULUS PRESCALER	

R3261/3361
 INPUT ATT
 BTB-015641 (1/1)

Parts No.	Advantest Stock No.	Description					Note
C1	CCP-ADR47U50V	FXD	CHIP	0.47 μ F	+80%, -80%	50V	
C2	CCP-ADR47U50V	FXD	CHIP	0.47 μ F	+80%, -80%	50V	
K1	KRL-000350	RELAY					
K2	KRL-000350-2	RELAY					
R1	RMF-BQ96R2QFK-1	FXD	METAL	96.2 Ω	\pm 1%	1/4W	
R2	RMF-BR71R2QFK-1	FXD	METAL	71.2 Ω	\pm 1%	1/4W	
R3	RCP-AN100	FXD	CHIP	100 Ω	\pm 0.5%	1/10W	
R4	RCP-BE61R1-1	FXD	CHIP	61.1 Ω	\pm 1%	1/2W	
R6	RCP-AN120	FXD	CHIP	120 Ω	\pm 0.5%	1/10W	
R7	RCP-AN130	FXD	CHIP	130 Ω	\pm 0.5%	1/10W	
R8	RCP-AN62	FXD	CHIP	62 Ω	\pm 0.5%	1/10W	
R9	RCP-AN62	FXD	CHIP	62 Ω	\pm 0.5%	1/10W	
R10	RCP-AN120	FXD	CHIP	120 Ω	\pm 0.5%	1/10W	
R11	RCP-AN130	FXD	CHIP	130 Ω	\pm 0.5%	1/10W	
R12	RCP-AN62	FXD	CHIP	62 Ω	\pm 0.5%	1/10W	

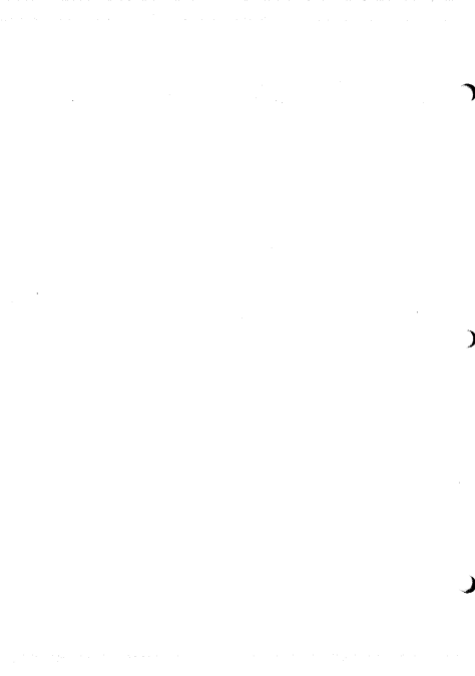

R3261/3361
 IST MIXER
 BTB-015642 (1/1)

Parts No.	Advantest Stock No.	Description	Note
D1	SDS-DMJ4317	SCHOTTKY BARRIER SI DIODE	
R1	RCP-AH100	FXD CHIP 1000 ±5% 1/8W	
R2	RCP-AH470	FXD CHIP 4700 ±5% 1/8W	
R3	RCP-AJ100	FXD CHIP 1000 ±5% 1/10W	
R6	RCP-AJ100	FXD CHIP 1000 ±5% 1/10W	

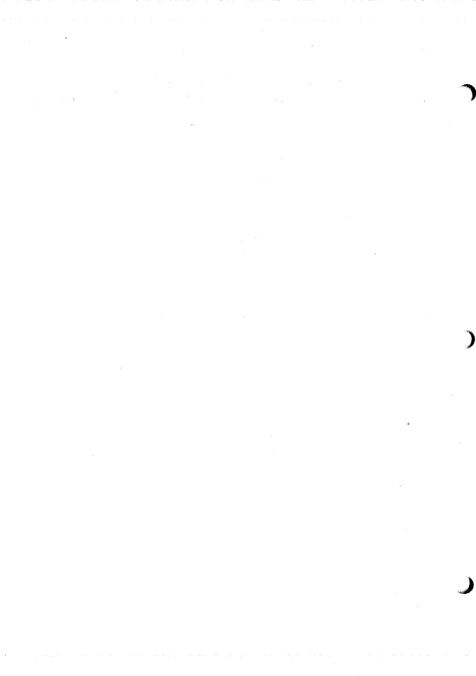

R3261/3361
2ND CONV
BTD-015644 (1/3)

Parts No.	Advantest Stock No.	Description	Note
C1	CCP-TCR1U50V	FXD CHIP 1 μ F +80%, -20% 50V	
C2	CCP-AT10PR1K	FXD CHIP 10PF \pm 1PF 100V	
C3	CCP-TCR1U50V	FXD CHIP 0.1 μ F +80%, -20% 50V	
C4	CCP-BA100P50V	FXD CHIP 100PF \pm 10% 50V	
C5	CCK-BX33U25V	FXD ELECT 33 μ F \pm 20% 25V	
C6	CCP-ADR47U50V	FXD CHIP 0.47 μ F +80%, -20% 50V	
C7	CCP-BA100P50V	FXD CHIP 100PF \pm 10% 50V	
C8	CCP-BA100P50V	FXD CHIP 100PF \pm 10% 50V	
C9	CCP-BAR01U50V	FXD CHIP 0.01 μ F \pm 10% 50V	
C10	CCP-BA100P50V	FXD CHIP 100PF \pm 10% 50V	
C11	CCP-BA10P50V	FXD CHIP 10PF \pm 0.5PF 50V	
C12	CCP-BA10P50V	FXD CHIP 10PF \pm 0.5PF 50V	
C13	CCP-BA100P50V	FXD CHIP 100PF \pm 10% 50V	
C14	CCP-BA10P50V	FXD CHIP 10PF \pm 0.5PF 50V	
C15	CCP-BA100P50V	FXD CHIP 100PF \pm 10% 50V	
C16	CCP-BA100P50V	FXD CHIP 100PF \pm 10% 50V	
C17	CCP-BAR01U50V	FXD CHIP 0.01 μ F \pm 10% 50V	
C18	CCP-BA1000P50V	FXD CHIP 1000PF \pm 10% 50V	
C19	CCP-BAR01U50V	FXD CHIP 0.01 μ F \pm 10% 50V	
C20	CCP-BAR01U50V	FXD CHIP 0.01 μ F \pm 10% 50V	
C21	CTM-BM10P	VAR 10PF +50%, -0% 100V	
C22	CCP-BA5P50V	FXD CHIP 5PF \pm 0.5PF 50V	
C23	CCP-BA5P50V	FXD CHIP 5PF \pm 0.5PF 50V	
C30	CCP-BA15P50V	FXD CHIP 15PF \pm 5% 50V	
C31	CCP-BA1000P50V	FXD CHIP 1000PF \pm 10% 50V	
C32	CCP-BAR01U50V	FXD CHIP 0.01 μ F \pm 10% 50V	
C34	CCP-BA1000P50V	FXD CHIP 1000PF \pm 10% 50V	
C35	CCP-BAR01U50V	FXD CHIP 0.01 μ F \pm 10% 50V	
C37	CCP-BA1000P50V	FXD CHIP 1000PF \pm 10% 50V	
C38	CCP-BA2P50V	FXD CHIP 2PF \pm 0.25PF 50V	
C39	CCP-BA1000P50V	FXD CHIP 1000PF \pm 10% 50V	
C41	CCP-BAR01U50V	FXD CHIP 0.01 μ F \pm 10% 50V	
C42	CCP-BA2P50V	FXD CHIP 2PF \pm 0.25PF 50V	
C43	CCP-BAR01U50V	FXD CHIP 0.01 μ F \pm 10% 50V	
C44	CCP-BA1000P50V	FXD CHIP 1000PF \pm 10% 50V	
D1	SDS-1S5101	SCHOTTKY BARRIER SI DIODE UHF MIXER	
D2	SOZ-W120	ZENER DIODE	
D5	SDS-ND587T	MIXER DIODE	
DR1	DXD-001681-1	DR 4GHz	
DR3	DXD-001285	DR 3.72GHz	

R3261/3361
2ND CONV
BTD-015644 (2/3)

Parts No.	Advantest Stock No.	Description	Note
PL1	DFN-001089	B.P.F 226.4MHz	
J1	JCF-BA001JX01	CONNECTOR	
L1	LCL-A00671	COIL (CUSTOM DEVICE)	
L3	LCL-A00785	COIL (CUSTOM DEVICE)	
L10	LCL-A00671	COIL (CUSTOM DEVICE)	
L11	LCL-E00934	COIL CHIP 33nH $\pm 20\%$	
L12	LCL-E00938	COIL CHIP 82nH $\pm 20\%$	
L13	LCL-E00388	COIL (CUSTOM DEVICE)	
L14	LCL-A00063	COIL (CUSTOM DEVICE)	
Q1	STN-25C3604	TRANSISTOR NPN	
Q2	STN-25C3604	TRANSISTOR NPN	
Q3	STN-25C3604	TRANSISTOR NPN	
Q10	STN-25C3356	TRANSISTOR NPN	
R1	RCP-AN330	FXD CHIP 330 Ω $\pm 0.5\%$ 1/10W	
R2	RCP-AN1K	FXD CHIP 1k Ω $\pm 0.5\%$ 1/10W	
R3	RCB-AG2R7K	FXD CAR 2.7k Ω $\pm 5\%$ 1/8W	
R4	RCP-AN3R3K	FXD CHIP 3.3k Ω $\pm 0.5\%$ 1/10W	
R5	RCP-AN100	FXD CHIP 100 Ω $\pm 0.5\%$ 1/10W	
R6	RCP-AJ100	FXD CHIP 100 Ω $\pm 5\%$ 1/10W	
R7	RCP-AJ10K	FXD CHIP 10k Ω $\pm 5\%$ 1/10W	
R8	RCP-AJ150	FXD CHIP 150 Ω $\pm 5\%$ 1/10W	
R9	RCP-AJ33	FXD CHIP 33 Ω $\pm 5\%$ 1/10W	
R10	RCP-AJ150	FXD CHIP 150 Ω $\pm 5\%$ 1/10W	
R11	RCP-AJ1K	FXD CHIP 1k Ω $\pm 5\%$ 1/10W	
R12	RCP-AH680	FXD CHIP 680 Ω $\pm 5\%$ 1/8W	
R15	RCP-AJ100	FXD CHIP 100 Ω $\pm 5\%$ 1/10W	
R19	RCP-AJ1K	FXD CHIP 1k Ω $\pm 5\%$ 1/10W	
R20	RCP-AH330	FXD CHIP 330 Ω $\pm 5\%$ 1/8W	
R30	RCP-AJ10K	FXD CHIP 10k Ω $\pm 5\%$ 1/10W	
R31	RCP-AJ8R2	FXD CHIP 8.2 Ω $\pm 10\%$ 1/10W	
R32	RCP-AJ3R3K	FXD CHIP 3.3k Ω $\pm 5\%$ 1/10W	
R33	RCP-AH180	FXD CHIP 180 Ω $\pm 5\%$ 1/8W	
R35	RCP-AJ100	FXD CHIP 100 Ω $\pm 5\%$ 1/10W	
R36	RCP-AJ350	FXD CHIP 350 Ω $\pm 5\%$ 1/10W	
R37	RCP-AJ4R7K	FXD CHIP 4.7k Ω $\pm 5\%$ 1/10W	
R38	RCP-AJ220	FXD CHIP 220 Ω $\pm 5\%$ 1/10W	
R40	RCP-AJ68	FXD CHIP 68 Ω $\pm 5\%$ 1/10W	
R41	RCP-AJ470	FXD CHIP 470 Ω $\pm 5\%$ 1/10W	
R42	RCP-AJ68	FXD CHIP 68 Ω $\pm 5\%$ 1/10W	
R45	RCP-AJ10	FXD CHIP 10 Ω $\pm 5\%$ 1/10W	

R3261/3361
 2ND CONV
 BTD-015644 (3/3)

Parts No.	Advantest Stock No.	Description	Note
U1	SHB-001698-1	CUSTOM DEVICE	
U2	SHB-001698-1	CUSTOM DEVICE	
U3	SIC-UPG501B	5GHz 1/4 PRESCALER	
U4	SIC-565	1GHz PRESCALER	
U5	SIA-79L12	Voltage Regulator 12V	
U10	SIA-1678	Bipolar Analog IC 1GHz Amp	
U11	SIA-1678	Bipolar Analog IC 1GHz Amp	

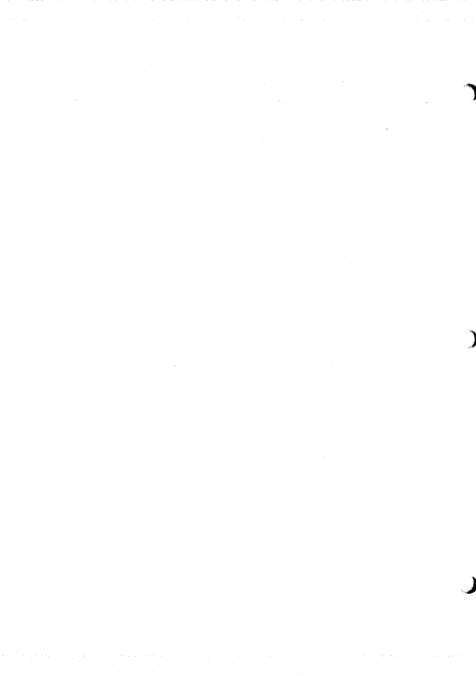

R3261/3361
 TG BLOCK
 WBL-3361TG (1/1)

Parts No.	Advantest Stock No.	Description	Note
	BED-015986 BLB-015987 BLC-015980 BLC-015681 BLD-015988		
	BTB-015678 BTB-015722 BTB-015723		
C1	CFT-AQ1000P50V	FXD COAXIAL 1000PF +50%, -20% 50V	
C5	CFT-AQ1000P50V	FXD COAXIAL 1000PF +50%, -20% 50V	
CB1	ZCA-A0142X29	CABLE ASSEMBLY	
FL1	DNF-001052	EMI FILTER	
FL12	DNF-001052	EMI FILTER	
FL16	DNF-001052	EMI FILTER	
J1	JCF-AF001.JX09	CONNECTOR N	
J2	JCF-AA001.JX01	CONNECTOR SMA	
J3	JCF-AC001.JX02	CONNECTOR UM	
J4	JTF-AB001EX04	CONNECTOR BNC	

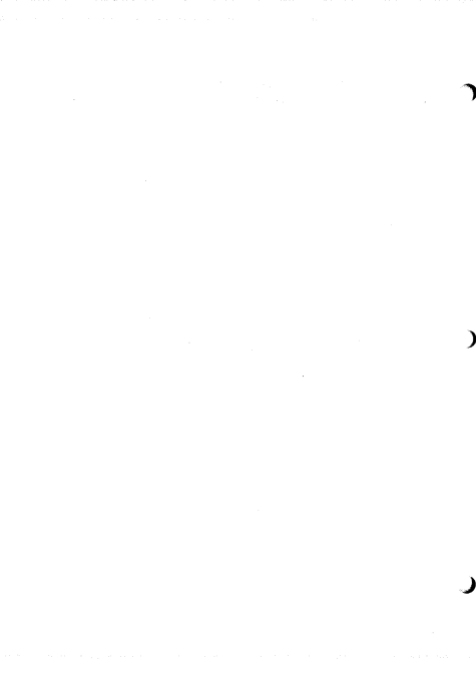

R3261/3361
OUTPUT AMP
 BED-015986 (1/3)

Parts No.	Advantest Stock No.	Description			Note
C1	CCP-TA1U16V-1	FXD	CHIP	1 μ F +80%, -20% 16V	
C2	CCP-BBR1U50V	FXD	CHIP	0.1 μ F +80%, -20% 50V	
C3	CCP-AT3PR1K	FXD	CHIP	3PF \pm 0.5PF 100V	
C4	CCP-ADR47U50V	FXD	CHIP	0.47 μ F +80%, -20% 50V	
C5	CCP-BAR01U50V	FXD	CHIP	0.01 μ F \pm 10% 50V	
C8	CCP-ADR47U50V	FXD	CHIP	0.47 μ F +80%, -20% 50V	
C9	CCP-BAR01U50V	FXD	CHIP	0.01 μ F \pm 10% 50V	
C12	CCP-ADR47U50V	FXD	CHIP	0.47 μ F +80%, -20% 50V	
C13	CCP-BAR01U50V	FXD	CHIP	0.01 μ F \pm 10% 50V	
C16	CCP-TA1U16V-1	FXD	CHIP	1 μ F +80%, -20% 16V	
C18	CCP-TF1U50V	FXD	CHIP	1 μ F +80%, -20% 50V	
C19	CCP-BAR01U50V	FXD	CHIP	0.01 μ F \pm 10% 50V	
C25	CCP-ADR47U50V	FXD	CHIP	0.47 μ F +80%, -20% 50V	
C26	CCP-TA1U16V-1	FXD	CHIP	1 μ F +80%, -20% 16V	
C27	CCP-BAR01U50V	FXD	CHIP	0.01 μ F \pm 10% 50V	
C28	CCP-TA1U16V-1	FXD	CHIP	1 μ F +80%, -20% 16V	
C31	CTA-A26RB8U16V	FXD	TA	6.8 μ F \pm 20% 16V	
C32	CCP-BAR01U50V	FXD	CHIP	0.01 μ F \pm 10% 50V	
C36	CCP-ADR47U50V	FXD	CHIP	0.47 μ F +80%, -20% 50V	
D1	SDS-ND4141	Si SCHOTTKY BARRIER DIODE			
D2	SDS-15S242	Si SCHOTTKY BARRIER DIODE			
D3	SDS-HSM2638CTR	Si DOUBLE DIODE			
K1	KPL-000350-2	RELAY SWITCH			
K4	KPL-000350-1	RELAY SWITCH			
L1	LCL-A00671	COIL	(CUSTOM DEVICE)		
L3	LCL-T00889	COIL	(CUSTOM DEVICE)		
L7	LCL-T00889	COIL	(CUSTOM DEVICE)		
L10	LCL-T00889	COIL	(CUSTOM DEVICE)		
L11	LCL-A00671	COIL	(CUSTOM DEVICE)		
Q1	SFN-2SK878	Al Ga As/Ga As N Channel HEMT			
Q2	STP-2SA1162	TRANSISTOR	PNP		
Q3	SFN-2SK571	N Channel Ga As MES-TYPE			
Q4	STP-2SA1162	TRANSISTOR	PNP		
Q5	SFN-900075	Ga As Power FET			
Q6	STP-2SA1162	TRANSISTOR	PNP		
R1	RAY-BRX0003	FXD	(CUSTOM DEVICE)		
R2	RMF-BL470QFJ	FXD	METAL	4700 \pm 1% 1/4W	
R3	RCP-AJ1B0	FXD	CHIP	1800 \pm 5% 1/10W	
R4	RAY-BRX0006	FXD	(CUSTOM DEVICE)		
R5	RCP-AJ1K	FXD	CHIP	1k Ω \pm 5% 1/10W	

R3261/3361
 OUTPUT AMP
 BED-015986 (2/3)

Parts No.	Advantest Stock No.	Description	Note
R6	RCP-AJ6R8K	FXD CHIP 6.8k Ω \pm 5% 1/10W	
R7	RCP-AJ1R5K	FXD CHIP 1.5k Ω \pm 5% 1/10W	
R8	RCP-AJ1K	FXD CHIP 1k Ω \pm 5% 1/10W	
R9	RMF-BL470QFJ	FXD METAL 470 Ω \pm 1% 1/4W	
R10	RCP-AJ12K	FXD CHIP 12k Ω \pm 5% 1/10W	
R11	RCP-AJ1R5K	FXD CHIP 1.5k Ω \pm 5% 1/10W	
R12	RAY-BRX0008	FXD (CUSTOM DEVICE)	
R13	RCP-AJ1K	FXD CHIP 1k Ω \pm 5% 1/10W	
R14	RCP-AJ6R8K	FXD CHIP 6.8k Ω \pm 5% 1/10W	
R15	RCP-AJ1R5K	FXD CHIP 1.5k Ω \pm 5% 1/10W	
R16	RCP-AJ1K	FXD CHIP 1k Ω \pm 5% 1/10W	
R17	RMF-BL820QFJ	FXD METAL 820 Ω \pm 1% 1/4W	
R19	RCP-AJ12K	FXD CHIP 12k Ω \pm 5% 1/10W	
R20	RCP-AJ1R8K	FXD CHIP 1.8k Ω \pm 5% 1/10W	
R21	RAY-BRX0003	FXD (CUSTOM DEVICE)	
R22	RCP-AJ1K	FXD CHIP 1k Ω \pm 5% 1/10W	
R23	RCP-AJ1R5K	FXD CHIP 1.5k Ω \pm 5% 1/10W	
R24	RCP-AJ6R8K	FXD CHIP 6.8k Ω \pm 5% 1/10W	
R25	RCP-AJ1K	FXD CHIP 1k Ω \pm 5% 1/10W	
R26	RMF-BL470QFJ	FXD METAL 470 Ω \pm 1% 1/4W	
R30	RCP-AJ12K	FXD CHIP 12k Ω \pm 5% 1/10W	
R31	RCP-AJ1R8K	FXD CHIP 1.8k Ω \pm 5% 1/10W	
R32	RCB-AG1K	FXD CHIP 1k Ω \pm 5% 1/8W	
R33	RCP-AH470	FXD CHIP 470 Ω \pm 5% 1/8W	
R34	RCP-AJ22	FXD CHIP 22 Ω \pm 5% 1/10W	
R36	RCP-AJ10K	FXD CHIP 10k Ω \pm 5% 1/10W	
R37	RCP-AJ2R2K	FXD CHIP 2.2k Ω \pm 5% 1/10W	
R38	RCP-AJ51	FXD CHIP 51 Ω \pm 5% 1/10W	
R39	RCP-AJ220	FXD CHIP 220 Ω \pm 5% 1/10W	
R40	RCP-AN180	FXD CHIP 180 Ω \pm 0.5% 1/10W	
R41	RCP-AN30	FXD CHIP 30 Ω \pm 0.5% 1/10W	
R42	RCP-AN180	FXD CHIP 180 Ω \pm 0.5% 1/10W	
R43	RCP-AN68	FXD CHIP 68 Ω \pm 0.5% 1/10W	
R44	RCP-AN130	FXD CHIP 130 Ω \pm 0.5% 1/10W	
R45	RCP-AN68	FXD CHIP 68 Ω \pm 0.5% 1/10W	
R46	RCP-AN68	FXD CHIP 68 Ω \pm 0.5% 1/10W	
R47	RCP-AN130	FXD CHIP 130 Ω \pm 0.5% 1/10W	
R48	RCP-AN68	FXD CHIP 68 Ω \pm 0.5% 1/10W	
R49	RCP-AM91	FXD CHIP 91 Ω \pm 1% 1/8W	
R50	RCP-AM68	FXD CHIP 68 Ω \pm 1% 1/8W	

R3261/3361
 OUTPUT AMP
 BED-015986 (3/3)

Parts No.	Advantest Stock No.	Description	Note
R51	RCP-AM91	FXD CHIP 91Ω ±1% 1/8W	
R52	RAY-BRX0003	FXD (CUSTOM DEVICE)	
R53	RMF-BL470QFJ	FXD METAL 470Ω ±1% 1/4W	
R54	RCP-AJ2R2K	FXD CHIP 2.2kΩ ±5% 1/10W	
R55	RCP-AJ10K	FXD CHIP 10kΩ ±5% 1/10W	
R56	RCP-AN200K-1	FXD CHIP 200kΩ ±0.5% 1/10W	
R57	RCP-AJ1K	FXD CHIP 1kΩ ±5% 1/10W	
R58	RCP-AJ15K	FXD CHIP 15kΩ ±5% 1/10W	
R61	RCP-AJ6R8K	FXD CHIP 6.8kΩ ±5% 1/10W	
R65	RCB-AH1R5K-1	FXD CAR 1.5kΩ ±5% 1/8W	
U1	SIA-MAR7	MONOLITHIC AMPLIFIER 2GHz	
U3	SIA-OP07PS	OP AMP ULTRA-LOW OFFSET	

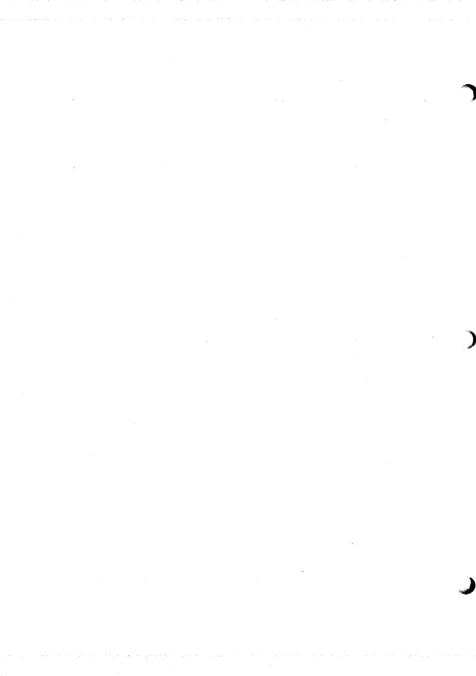

R3261/3361
TG SAMPLER
BLB-015867 (1/1)

Parts No.	Advantest Stock No.	Description					Note
C1	CCP-AT24PR1K	FXD	CHIP	24PF	±5%	100V	
C3	CCP-AT12PR1K	FXD	CHIP	12PF	±10%	100V	
C4	CCP-BA2200P50V	FXD	CHIP	2200PF	±20%	50V	
C6	CCP-BBR1U50V	FXD	CHIP	0.1 μ F	+80%, -20%	50V	
C8	CCP-BA2200P50V	FXD	CHIP	2200PF	±20%	50V	
C10	CCP-BA2P50V	FXD	CHIP	2PF	±0.25PF	50V	
C14	CCP-BBR1U50V	FXD	CHIP	0.1 μ F	+80%, -20%	50V	
C15	CCP-BA2P50V	FXD	CHIP	2PF	±0.25PF	50V	
C16	CCP-AT30PR1K	FXD	CHIP	30PF	±5%	100V	
C17	CCP-BA2P50V	FXD	CHIP	2PF	±0.25PF	50V	
C18	CCP-BA5P50V	FXD	CHIP	5PF	±0.5PF	50V	
D1	SDS-1SV107	SI SNAP-OFF DIODE					
D2	SDS-1SS242	SI SCHOTTKY BARRIER DIODE					
L1	LCL-E00836	COIL	CHIP	47nH	±20%		
L2	LCL-E00837	COIL	CHIP	85nH	±20%		
L3	LCL-E00836	COIL	CHIP	47nH	±20%		
L4	LCL-A00777	COIL	(CUSTOM DEVICE)				
Q1	STN-29C3357	TRANSISTOR		NPN			
R1	RCP-AJ270	FXD	CHIP	270 Ω	±5%	1/10W	
R2	RCP-AJ18	FXD	CHIP	18 Ω	±5%	1/10W	
R3	RCP-AJ270	FXD	CHIP	270 Ω	±5%	1/10W	
R4	RCP-AJ4R7K	FXD	CHIP	4.7k Ω	±5%	1/10W	
R6	RCB-AQ220	FXD	CAR	220 Ω	±5%	1/4W	
R10	RCP-AJ1K	FXD	CHIP	1k Ω	±5%	1/10W	
R12	RCP-AJ100K	FXD	CHIP	100k Ω	±5%	1/10W	
R14	RCP-AJ270	FXD	CHIP	270 Ω	±5%	1/10W	
R15	RCP-AJ18	FXD	CHIP	18 Ω	±5%	1/10W	
R16	RCP-AJ270	FXD	CHIP	270 Ω	±5%	1/10W	
U1	SIA-1675	Bipolar Analog IC 1GHz Amp					

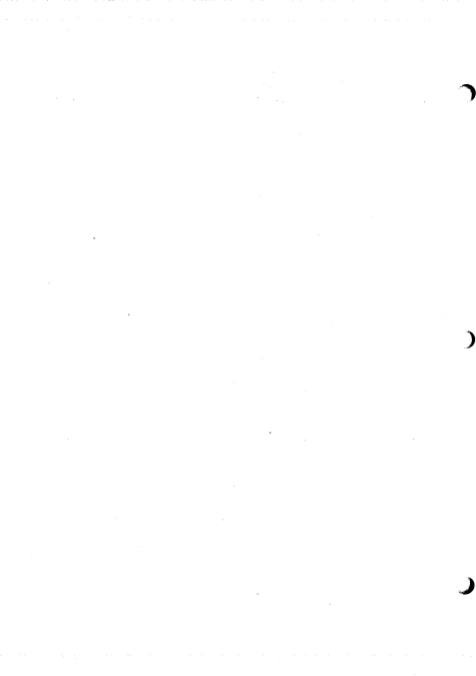

R3261/3361
ALC CONT
BLQ-015680 (1/2)

Parts No.	Advantest Stock No.	Description				Note
C1-2	CCP-AE1U50V	FXD	CHIP	1 μ F	+80%,-20%	50V
C3	CFM-AS3300P50V	FXD	FILM	3300PF	\pm 10%	50V
C4	CFM-ASR047U50V	FXD	FILM	0.047 μ F	\pm 10%	50V
C5-20	CCP-8BR1U50V	FXD	CHIP	0.1 μ F	+80%,-20%	50V
C21-23	CCP-8BR1U50V	FXD	CHIP	0.1 μ F	+80%,-20%	50V
D1	SDS-LS955		DIODE SI			
D2	SDS-LS955		DIODE SI			
D3	SDZ-MOS1		ZENER			DIODE
D4-5	SDS-LS955		DIODE SI			
D6	SDS-LS955		DIODE SI			
J1	JCP-AR010JX02		CONNECTOR			
Q2	STP-2SA1204		TRANSISTOR PNP			
R1	RCP-AN10K	FXD	CHIP	10K Ω	\pm 5%	1/10W
R2	RCP-AN4R7K	FXD	CHIP	4.7K Ω	\pm 5%	1/10W
R3	RCP-AN56K	FXD	CHIP	50K Ω	\pm 5%	1/10W
R4	RCP-AN36K	FXD	CHIP	36K Ω	\pm 5%	1/10W
R5	RCP-AN1K	FXD	CHIP	1K Ω	\pm 5%	1/10W
R6	RCP-AN1R5K	FXD	CHIP	1.5K Ω	\pm 5%	1/10W
R7	RCP-AN6R2K	FXD	CHIP	6.2K Ω	\pm 5%	1/10W
R8	RCP-AH1R5K	FXD	CHIP	1.5K Ω	\pm 5%	1/10W
R9	RCP-AN100K	FXD	CHIP	100K Ω	\pm 5%	1/10W
R10	RCP-AN10K	FXD	CHIP	10K Ω	\pm 5%	1/10W
R11	RCP-AN36K	FXD	CHIP	36K Ω	\pm 5%	1/10W
R13-14	RCP-AN1K	FXD	CHIP	1K Ω	\pm 5%	1/10W
R15-16	RCP-AN10K	FXD	CHIP	10K Ω	\pm 5%	1/10W
R17	RCP-AN51K	FXD	CHIP	51K Ω	\pm 5%	1/10W
R18	RCP-AN10K	FXD	CHIP	10K Ω	\pm 5%	1/10W
R19	RCP-AN10K	FXD	CHIP	10K Ω	\pm 5%	1/10W
R20	RCP-AN22K	FXD	CHIP	22K Ω	\pm 5%	1/10W
R21	RCP-AN6R2K	FXD	CHIP	6.2K Ω	\pm 5%	1/10W
R22-23	RCP-AN10K	FXD	CHIP	10K Ω	\pm 5%	1/10W
R24	RCP-AN3R6K	FXD	CHIP	3.6K Ω	\pm 5%	1/10W
R25	RCP-AN22K	FXD	CHIP	22K Ω	\pm 5%	1/10W
R28-29	RCP-AN2R2K	FXD	CHIP	2.2K Ω	\pm 5%	1/10W
R30-31	RCP-AN10K	FXD	CHIP	10K Ω	\pm 5%	1/10W
R32	RCP-AN4R7K	FXD	CHIP	4.7K Ω	\pm 5%	1/10W
R33	RCP-AN2R2K	FXD	CHIP	2.2K Ω	\pm 5%	1/10W
R34	RCP-AN3R3K	FXD	CHIP	3.3K Ω	\pm 5%	1/10W
R35	RCP-AN10K	FXD	CHIP	10K Ω	\pm 5%	1/10W
R36	RCP-AN100	FXD	CHIP	100 Ω	\pm 5%	1/10W
R37	RCP-AN10K	FXD	CHIP	10K Ω	\pm 5%	1/10W
R38	RCB-AH10K	FXD	CAR	10K Ω	\pm 5%	1/4W
R40	RCB-AK120	FXD	CAR	120 Ω	\pm 5%	1/2W
R41	RAY-AL10K4	FXD	RA	10K Ω x 4	\pm 5%	1/8W
R42	RCP-AN10K	FXD	CHIP	10K Ω	\pm 5%	1/10W
R43	RVR-DF10K	VAR		10K Ω	\pm 20%	1/2W
R44	RVR-DF20K	VAR		20K Ω	\pm 20%	1/2W
R45	RCP-AN2R2K	FXD	CHIP	2.2K Ω	\pm 5%	1/10W
R46	RVR-DF1K	VAR		1K Ω	\pm 20%	1/2W
R47	RCP-AN22K	FXD	CHIP	22K Ω	\pm 5%	1/10W
R48	RCP-AN5R6K	FXD	CHIP	5.6K Ω	\pm 5%	1/10W

R3261/3361
 ALC CONT
 BLQ-015680 (2/2)

Part No.	Advantest Stock No.	Description	Note
U1-3	SIA-TL072CPS	OP AMP DUAL LOW NOISE	
U4-5	SIA-OP07PS	OP AMP LOW OFFSET	
U6	SIA-OP07PS	OP AMP LOW OFFSET	
U7	SIA-TL072CPS	OP AMP DUAL LOW NOISE	
U8	SIA-TC4S66F	ANALOG SWITCHES	
U9	SIT-7407S	HEX BUFFER (OPEN COLLECTOR)	
U10-12	SIA-TC4S66F	ANALOG SWITCHES	

R3261/3361
T.G CONT.
BLC-015681 (1/1)

Parts No.	Adventest Stock No.	Description	Note
C1	CCK-BX100U16V	FXD ELECT 100 μ F \pm 20% 16V	
C2	CCK-BX22U25V	FXD ELECT 22 μ F \pm 20% 25V	
C5	CCP-SBR1U50V	FXD CHIP 0.1 μ F +80% -20% 50V	
C9	CCP-AT12PR1K	FXD CHIP 12PF \pm 10% 100V	
C10	CCP-SBR1U50V	FXD CHIP 0.1 μ F +80% -20% 50V	
D1	SDS-LS955	ULTRA-HIGH SPEED SWITCHING DIODE	
D5	SDZ-5030	ZENER DIODE	
J1	JCR-AF026PX02	CONNECTOR	
J2	JCP-AR010PX01	CONNECTOR	
L1	LCL-T00084A	COIL (CUSTOM DEVICE)	
R1	RCP-AN12K	FXD CHIP 12k Ω \pm 0.5% 1/10W	
R2	RCP-AN1R8K	FXD CHIP 1.8k Ω \pm 0.5% 1/10W	
R3	RCP-AN22K	FXD CHIP 22k Ω \pm 0.5% 1/10W	
R4	RCP-AN5R1K	FXD CHIP 5.1k Ω \pm 0.5% 1/10W	
U1	SIM-CXD1085	I/O EXPANDER	
U2	SIA-DA7542	8-BIT D/A CONVERTER	
U3	SIA-TL072CPS	OP AMP DUAL LOW NOISE	
U4	SIT-DN8650	LOW ACTIVE DRIVERS	

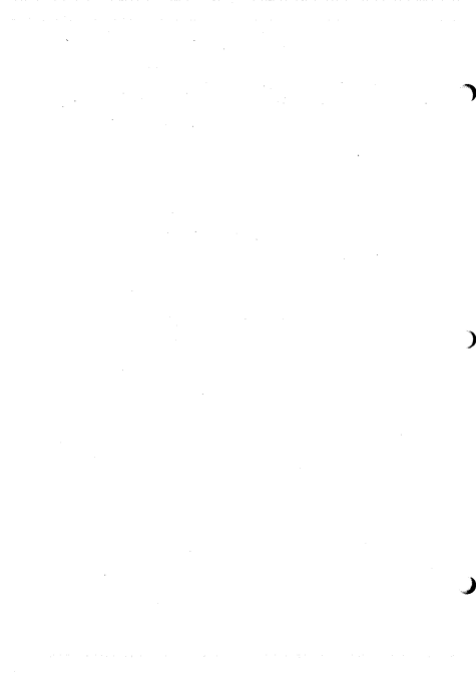

R3261/3361
TG PLL
BLD-015966 (1/2)

Parts No.	Advantest Stock No.	Description			Note	
C1	CCP-BA2200P50V	FXD	CHIP	2200PF ±20%	50V	
C3	CCP-BA68P50V	FXD	CHIP	68PF ±5%	50V	
C5	CCP-BBR1U50V	FXD	CHIP	0.1 μ F +80%, -20%	50V	
C6	CCP-BA2200P50V	FXD	CHIP	2200PF ±20%	50V	
C9	CCP-BA22P50V	FXD	CHIP	22PF ±10%	50V	
C10	CCP-BA2200P50V	FXD	CHIP	2200PF ±20%	50V	
C11	CCP-BA68P50V	FXD	CHIP	68PF ±5%	50V	
C13	CCP-BA2200P50V	FXD	CHIP	2200PF ±20%	50V	
C14	CCP-BBR1U50V	FXD	CHIP	0.1 μ F +80%, -20%	50V	
C15	CCP-ADR022U50V	FXD	CHIP	0.022 μ F +80%, -20%	50V	
C16	CCP-BBR1U50V	FXD	CHIP	0.1 μ F +80%, -20%	50V	
C17	CCP-ADR022U50V	FXD	CHIP	0.022 μ F +80%, -20%	50V	
C18	CCP-BBR1U50V	FXD	CHIP	0.1 μ F +80%, -20%	50V	
C21	CFM-AS2200P50V	FXD	FILM	2200PF ±10%	50V	
C22	CFM-ANR1U50V	FXD	FILM	0.1 μ F ±5%	50V	
C23	CCP-BBR1U50V	FXD	CHIP	0.1 μ F +80%, -20%	50V	
C25	CCP-TF1U50V	FXD	CHIP	1 μ F +80%, -20%	50V	
C26	CCK-BX100U10V	FXD	ELECT	100 μ F ±20%	10V	
C27	CCK-BX22U25V	FXD	ELECT	22 μ F ±20%	25V	
C29	CCP-BBR1U50V	FXD	CHIP	0.1 μ F +80%, -20%	50V	
C31	CCP-BA18P50V	FXD	CHIP	18PF ±10%	50V	
C32	CSM-TG1U50V	FXD	CER	1 μ F +80%, -20%	50V	
D1	SDZ-M130	ZENER DIODE				
J1	JCP-CJ003PX01	CONNECTOR				
J2	JCP-CJ002JX01	CONNECTOR				
L1	LCL-E00852	COIL	CHIP	1 μ H ±20%		
L2	LCL-E00841	COIL	CHIP	120nH ±10%		
L3	LCL-E00843	COIL	CHIP	180nH ±10%		
L4	LCL-E00841	COIL	CHIP	120nH ±10%		
L6	LCL-E00843	COIL	CHIP	180nH ±10%		
L7	LCL-E00841	COIL	CHIP	120nH ±10%		
L8	LCL-T00084A	COIL	(CUSTOM DEVICE)			
L9	LCL-C00010	COIL	CHIP	180 μ H ±10%		
Q1	STN-2SC1623	TRANSISTOR			NPN	
Q3	STP-2SA1204	TRANSISTOR			PNP	
Q4	STN-RN1404	TRANSISTOR			NPN	
Q6	STP-2SA1204	TRANSISTOR			PNP	
Q7	STN-RN2401	TRANSISTOR			NPN	
R1	RCP-AH82	FXD	CHIP	82 Ω ±5%	1/8W	
R2	RCP-AJ51	FXD	CHIP	51 Ω ±5%	1/10W	

R3261/3361
 TG PLL
 BLD-015968 (2/2)

Parts No.	Advantest Stock No.	Description	Note
R3	RCP-AJ1K	FXD CHIP 1k Ω \pm 5% 1/10W	
R4	RCP-AH470	FXD CHIP 470 Ω \pm 5% 1/8W	
R5	RCB-AK1K	FXD CAR 1k Ω \pm 5% 1/2W	
R6	RCP-AJ1K	FXD CHIP 1k Ω \pm 5% 1/10W	
R9	RCP-AH470	FXD CHIP 470 Ω \pm 5% 1/8W	
R10	RCP-AJ1R8K	FXD CHIP 1.8k Ω \pm 5% 1/10W	
R11	RCP-AJ10K	FXD CHIP 10k Ω \pm 5% 1/10W	
R12	RCP-AJ4R7K	FXD CHIP 4.7k Ω \pm 5% 1/10W	
R15	RCP-AJ1K	FXD CHIP 1k Ω \pm 5% 1/10W	
U1	SIA-MAR6	MONOLITHIC AMPLIFIER 2GHz	
U2	SIA-1675	Bipolar Analog IC 1GHz Amp	
U5	SIC-555	LOW POWER 2-MODULUS PRESCALER	
U6	SIA-OP07P	OP AMP ULTRA-LOW OFFSET	
U7	SMB-001510	CUSTOM DEVICE	
U8	SIM-74HC00	QUAD 2 INPUT POS-NAND	
X1	DXC-001688	CRYSTAL	

R3261/3361
4GHZ OSC
BTB-015676 (1/1)

Parts No.	Advantest Stock No.	Description	Note
C1	CCP-BAR01U50V	FXD CHIP 0.01 μ F \pm 10% 50V	
C3	CCP-BA4700P50V	FXD CHIP 4700PF \pm 10% 50V	
C4	CCP-AT7PR1K	FXD CHIP 7PF \pm 0.5PF 100V	
C5	CCP-BA10P50V	FXD CHIP 10PF \pm 0.5PF 50V	
C6	CCP-BAR01U50V	FXD CHIP 0.01 μ F \pm 10% 50V	
C11	CCP-BA10P50V	FXD CHIP 10PF \pm 0.5PF 50V	
C12	CCP-BA10P50V	FXD CHIP 10PF \pm 0.5PF 50V	
C13	CCP-BAR01U50V	FXD CHIP 0.01 μ F \pm 10% 50V	
D1	SDS-1SS101	SI SCHOTTKY BARRIER DIODE	
D2	SDS-15V34	SI PIN DIODE	
DR1	DXD-001691	DR 4GHz	
L2	LCL-A00773	COIL (CUSTOM DEVICE)	
L3	LCL-A00772	COIL (CUSTOM DEVICE)	
L4	LCL-A00671	COIL (CUSTOM DEVICE)	
Q1	STN-2SC4095	TRANSISTOR PNP	
Q2	SPN-2SK376	Al Ga As/Ga As N Channel HEMT	
Q3	STP-2SA1162	TRANSISTOR PNP	
R1	RCP-AJ1K	FXD CHIP 1k Ω \pm 5% 1/10W	
R3	RCP-AJ1K	FXD CHIP 1k Ω \pm 5% 1/10W	
R4	RCB-AH470	FXD CHIP 470 Ω \pm 5% 1/8W	
R5	RCP-AJ270	FXD CHIP 270 Ω \pm 5% 1/10W	
R6	RCP-AJ18	FXD CHIP 18 Ω \pm 5% 1/10W	
R7	RCP-AJ270	FXD CHIP 270 Ω \pm 5% 1/10W	
R8	RCP-AJ1K	FXD CHIP 1k Ω \pm 5% 1/10W	
R9	RCP-AJ1R5K	FXD CHIP 1.5k Ω \pm 5% 1/10W	
R10	RCP-AJ6R8K	FXD CHIP 6.8k Ω \pm 5% 1/10W	
R11	RCP-AJ3R9K	FXD CHIP 3.9k Ω \pm 5% 1/10W	
R12	RCP-AJ1K	FXD CHIP 1k Ω \pm 5% 1/10W	
R13	RCP-AJ1R5K	FXD CHIP 1.5k Ω \pm 5% 1/10W	
R14	RCP-AJ12K	FXD CHIP 12k Ω \pm 5% 1/10W	
R15	RCP-AJ1K	FXD CHIP 1k Ω \pm 5% 1/10W	
R16	RCB-AQB20	FXD CAR 820 Ω \pm 5% 1/4W	
R17	RCP-AJ270	FXD CHIP 270 Ω \pm 5% 1/10W	
R18	RCP-AJ18	FXD CHIP 18 Ω \pm 5% 1/10W	
R19	RCP-AJ270	FXD CHIP 270 Ω \pm 5% 1/10W	
R20	RCB-AQ330	FIX CAR 330 Ω \pm 5% 1/4W	

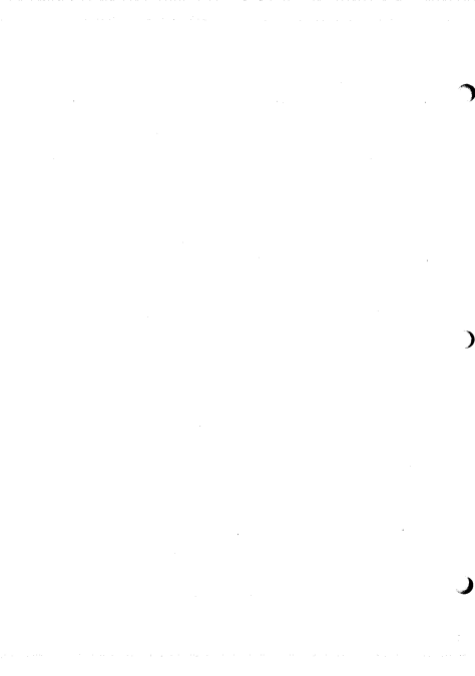

R3261/3361
 TG MIX-1
 BTB-015722 (1/1)

Parts No.	Advantest Stock No.	Description	Note
C1 U1	CCP-BBR1U50V SIA-S8708*14	FXD CHIP 0.1 μ F +80% -25% 50V Ga As MMIC AMP	

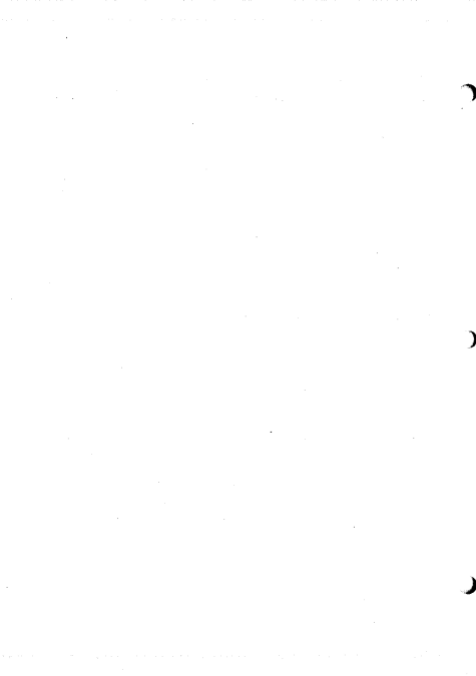

R3261/3361
 TG MIX-2
 BTB-016723 (1/1)

Parts No:	Advantest Stock No.	Description	Note
D1	SDS-MA4E204L2	SCHOTTKY BEAM-LEAD TEE	
R1	RCP-AH470	FXD CHIP 4700 ±5% 1.8W	
R2	RCP-AH100	FXD CHIP 1000 ±5% 1.8W	

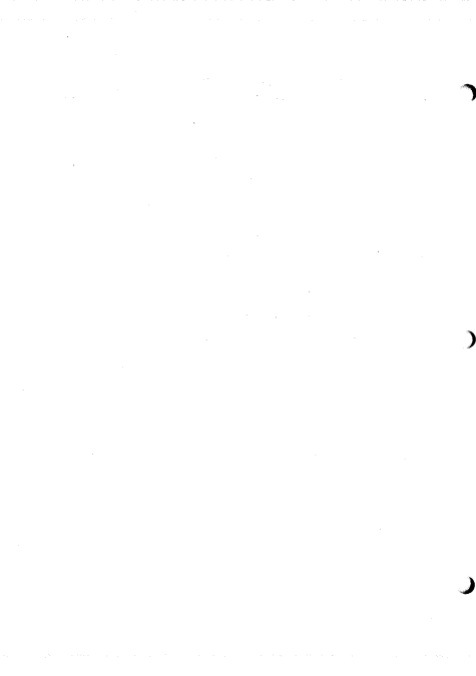

R3261/3361
MOTHER
BLH-015674 (1/1)

Parts No.	Advantest Stock No.	Description	Note
C1	CSM-TG1U50V	FXD CER 1 μ F +80%, -20% 50V	
C2	CSM-TG1U50V	FXD CER 1 μ F +80%, -20% 50V	
C3	CCK-CV470U16V	FXD ELECT 470 μ F \pm 20% 16V	
C4	CCK-CV470U16V	FXD ELECT 470 μ F \pm 20% 16V	
C6	CCK-BX47U35V	FXD ELECT 47 μ F \pm 20% 35V	
C7	CSM-TG1U50V	FXD CER 1 μ F +80%, -20% 50V	
C8	CSM-AZ1000P50V	FXD CER 1000PF \pm 10% 50V	
C9	CSM-AZ1000P50V	FXD CER 1000PF \pm 10% 50V	
D1	SDZ-W050	ZENER DIODE	
D2	SDZ-W050	ZENER DIODE	
D3	SDZ-W110	ZENER DIODE	
J1	JCS-BQ096JX01	CONNECTOR	
J2	JCS-BQ128JX01	CONNECTOR	
J3	JCS-BQ096JX01	CONNECTOR	
J6	JCR-AF050PX01	CONNECTOR	
J7	JCR-AF026PX01	CONNECTOR	
J8	DCB-RR0900X02-1	CABLE ASSEMBLY	
J9	JCF-AC001JX06	CONNECTOR	
J10	DCB-QS329X05-1	CABLE ASSEMBLY	
J11	JCP-AA012PX07	CONNECTOR	
J12	JCS-BZ002PX02	CONNECTOR	
J13	JCR-AF016PX02	CONNECTOR	
L1	LCL-T00084A	COIL (CUSTOM DEVICE)	
L2	LCL-T00084A	COIL (CUSTOM DEVICE)	
L3	LCL-B00811	COIL 1.5 μ H \pm 10%	
Q1	STP-2SA642-33	TRANSISTOR PNP	
Q2	STN-RN1002	TRANSISTOR NPN	
Q3	STN-25C2983	TRANSISTOR NPN	
R1	RAY-AL10KB	FXD RA 10k Ω \times 6 \pm 5%	
R2	RCB-AG470	FXD CAR 470 Ω \pm 5% 1/6W	
R3	RCB-AG470	FXD CAR 470 Ω \pm 5% 1/6W	
R4	RCB-AG220	FXD CAR 220 Ω \pm 5% 1/6W	
R5	RCB-AG560	FXD CAR 560 Ω \pm 5% 1/6W	
R6	RCB-AG330	FXD CAR 330 Ω \pm 5% 1/6W	
R7	RCB-AG10K	FXD CAR 10k Ω \pm 5% 1/6W	
U1	SIA-7808U	Voltage Regulator 8V	
U2	SIM-74HC05S	HEX INVERTERS OPEN-COLLECTOR OUTPUT	
U3	SMM-8464CS	8k WORD \times 8-BIT STATIC RAM	
U4	SMM-8464CS	8k WORD \times 8-BIT STATIC RAM	
U5	SIM-74HC138S	3 TO 8 LINE DECODERS/DEMULPLEXRS	

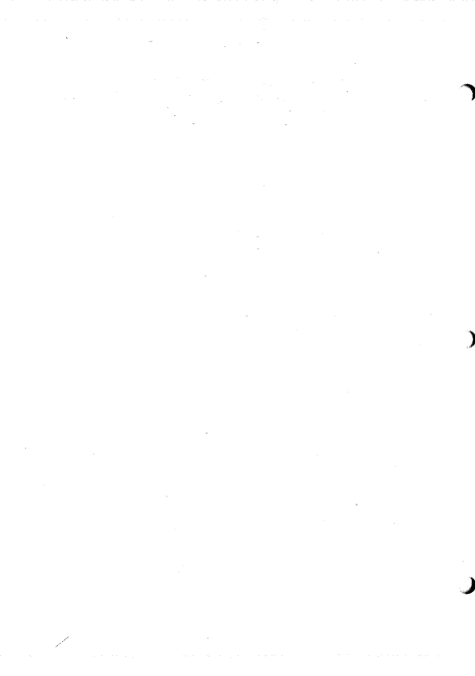

R3261/3361
BATT. HOLDER
BLB-018053 (1/1)

Parts No.	Advantest Stock No.	Description	Note
	DBP-000470 DCB-QR1937X02-1	Ni-cd BATTERY CABLE ASSEMBLY	

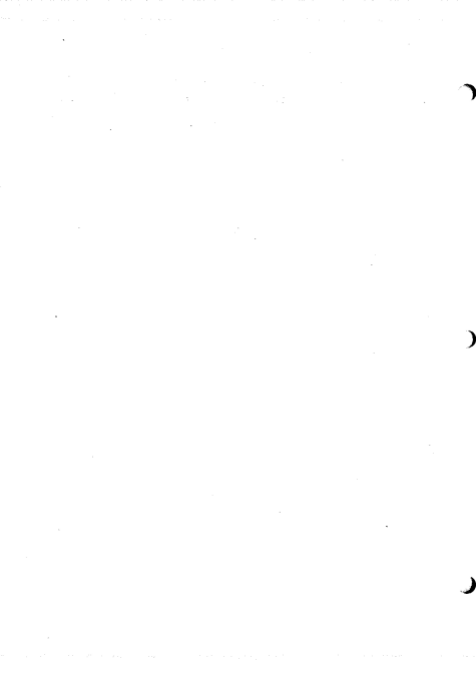

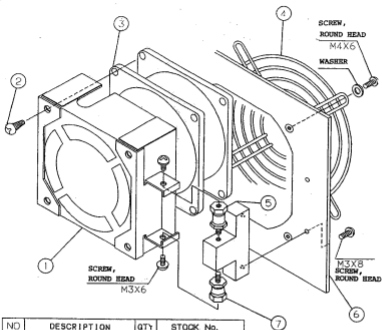

NO	DESCRIPTION	QTY	STOCK No.
1	FAN SHIELD	1	MBE-32047
2	SELF TAPPING SCREW	3	YKG-V01508
3	FAN	(1)	DMF-001006
4	FINGER GUARD	1	YEE-000271
5	FAN SUPPORT C	2	MKJ-32046
6	REAR PANEL	1	MCT-58898
7	RUBBER CUSHION	4	YEE-001489



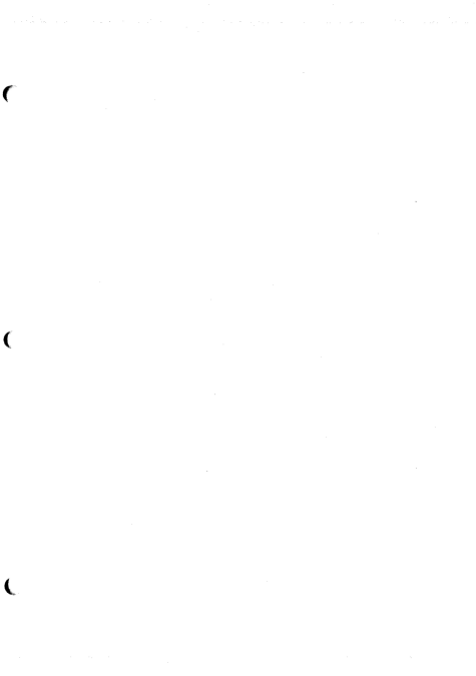

WARRANTY

ADVANTEST product is warranted against defects in material and workmanship for a period of one year from the date of delivery to original buyer.

LIMITATION OF WARRANTY

The foregoing warranty shall not apply to defects resulting from improper or inadequate maintenance by buyer, unauthorized modification or misuse, accident or abnormal conditions of operations.

No other warranty is expressed or implied. ADVANTEST specifically disclaims the implied warranties of merchantability and fitness for a particular purpose.

ADVANTEST shall not be liable for any special, incidental or consequential damages, whether in contract, tort or otherwise.

Any and all warranties are revoked if the product is removed from the country in which it was originally purchased.

SERVICE

During the warranty period, ADVANTEST will, at its option, either repair or replace products which prove to be defective.

When trouble occurs, buyer should contact his local supplier or ADVANTEST giving full details of the problem and the model name and serial number.

For the products returned to ADVANTEST for warranty service, buyer shall prepay shipping and transportation charges to ADVANTEST and ADVANTEST shall pay shipping and transportation charges to return the product to buyer. However, buyer shall pay all charges, duties, and taxes incurred in his country for products returned from ADVANTEST.

CLAIM FOR DAMAGE IN SHIPMENT TO ORIGINAL BUYER

The product should be thoroughly inspected immediately upon original delivery to buyer. All material in the container should be checked against the enclosed packing list or the instruction manual alternatively. ADVANTEST will not be responsible for shortage unless notified immediately.

If the product is damaged in any way, a claim should be filed by the buyer with carrier immediately. (To obtain a quotation to repair shipment damage, contact ADVANTEST or the local supplier.) Final claim and negotiations with the carrier must be completed by buyer.

SALES & SUPPORT OFFICES

438A Alexandra Road

#08-03/06 Alexandra Technopark Singapore 119967

Phone: 65-274-3100 Facsimile: 65-274-4055

ROHDE & SCHWARZ Engineering and Sales GmbH

Mühlhofstr. 15 (P.O.B. 80 1429, D-81614 Munich)

D-81671 Munich, Germany

Phone: 49-89-4129-3711 Facsimile: 49-89-4129-3223

TEKTRONIX INC.

P.O. Box 500, M/S 39-520, Beaverton, Oregon 97077-0001

or

Howard Vollum Industrial Park, M/S 58-743, Beaverton, OR, 97077, U.S.A.

Inside the U.S. 1-800-426-2200

Outside the U.S. 1-503-627-1933

Technology Secret or the Leading Edge

ADVANTEST

ADVANTEST CORPORATION

Shinjuku-NS Building, 4-1, Nishi-Shinjuku 2-chome, Shinjuku-ku, Tokyo 163-08, JAPAN
Phone: (03)3342-7500 Facsimile: (03)3342-7410 Telex: 232-6914 ADVAN J

3.4 Location

3.4.1 Block/Board Layout

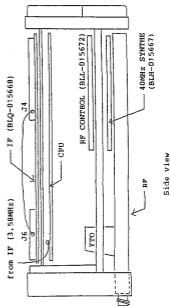
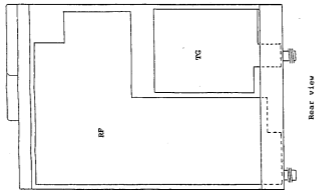
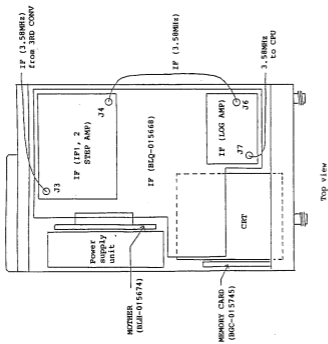

3.4.2 RF Block Internal View

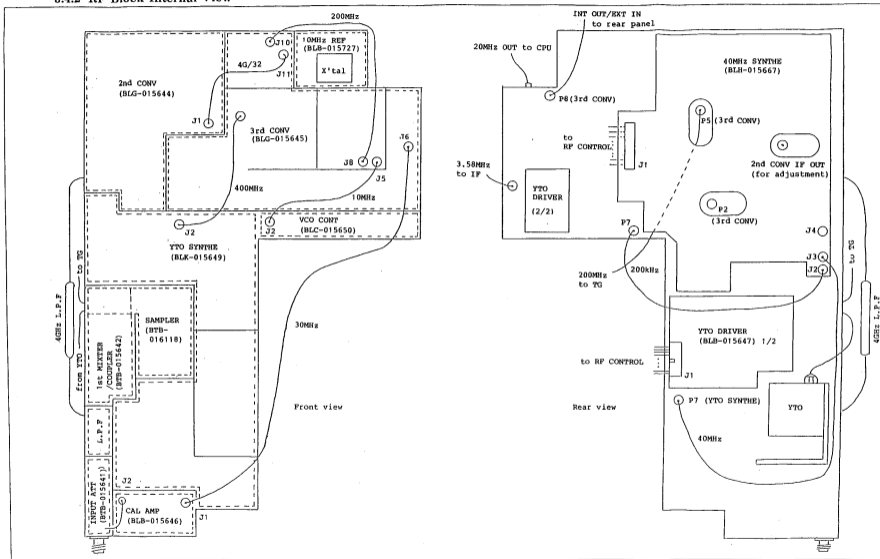
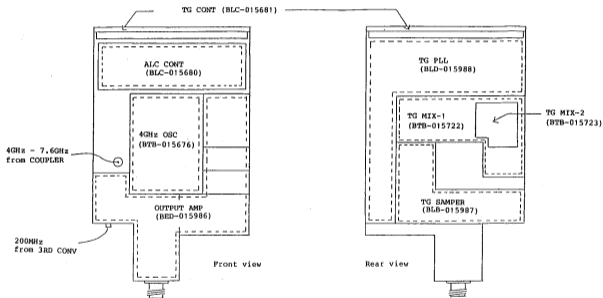

Figure 3-25 RF Block Internal View

3.4.3 TG Block Internal View



6. MAINTENANCE (TROUBLESHOOTING)

6.1 Level Down

Event : Level is low when CAL signal is displayed.
Level is low when external signal is input.

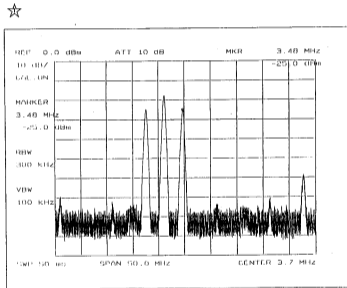
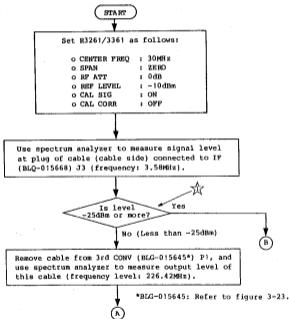

6.1 Level Down

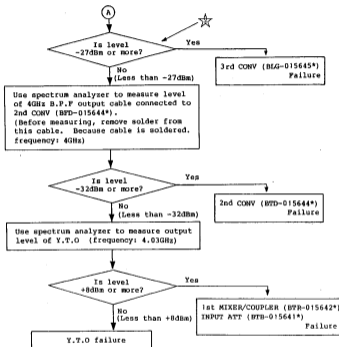

*BFD-015644, BIG-015645, BTR-015642, BTR-015641;
Refer to figure 3-23.

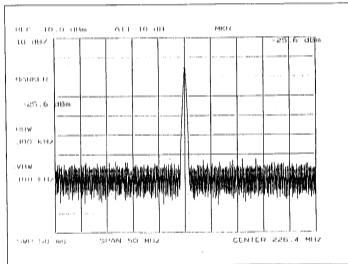

R3261/3361
SPECTRUM ANALYZER
MAINTENANCE MANUAL

6.1 Level Down

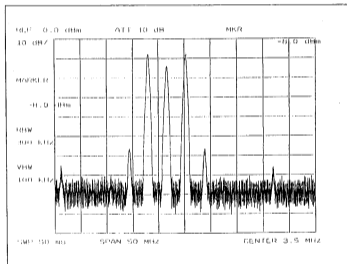
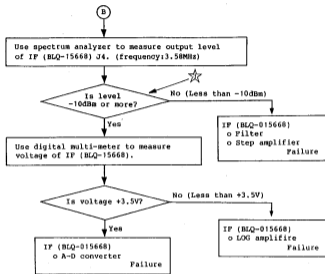

6.2 Unlock

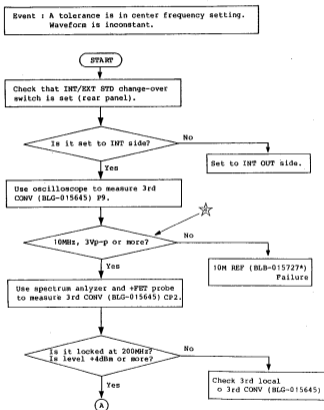

*BLB-015727: Refer to figure 3-23.

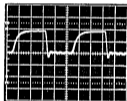

2V/Div

0.02µs/Div

6.2 Unlock

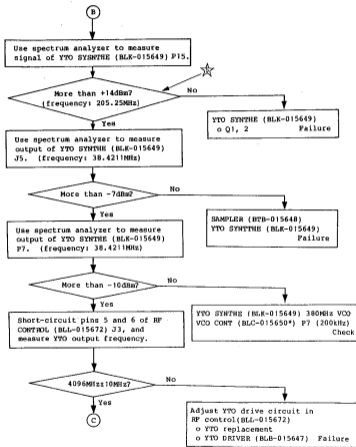

*BLC-015650: Refer to figure 3-23.

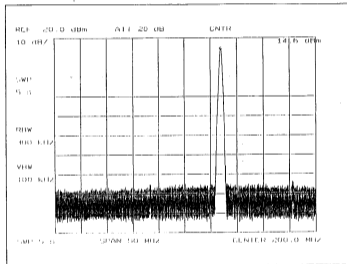

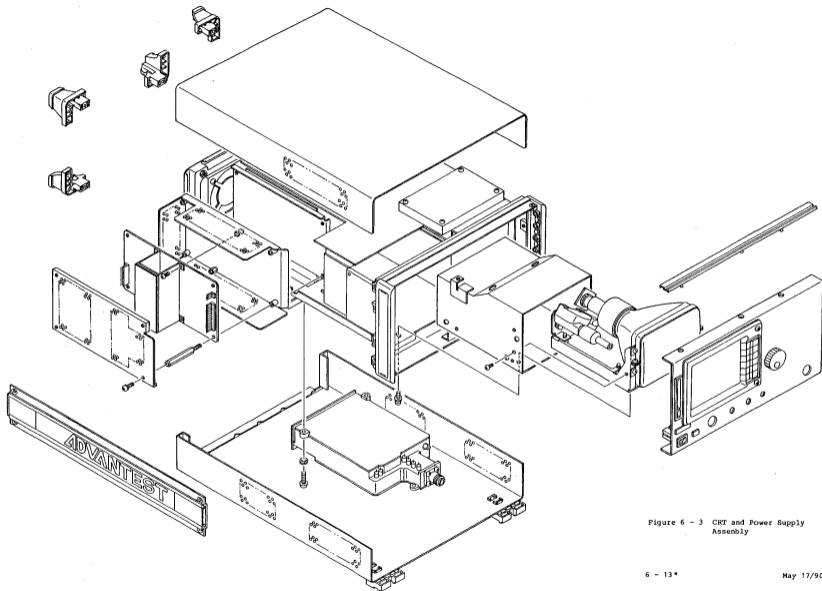
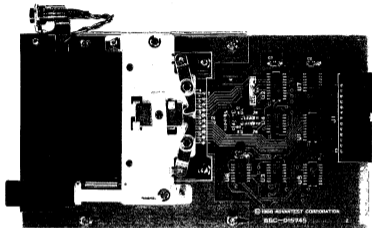

Figure 6 - 3 CRT and Power Supply Assembly



PARTS LOCATION
IC CARD
BGC-015745

1. DIAGRAMS ILLUSTRATION

1-1 SYMBOLS REFERENCE DESIGNATORS

1) IC PIN NAME (PIN-NAME OF NEGATIVE LOGIC ARE
DISPLAYED BY SMALL LETTER)



R3261/3361 IC CARD
BGC-015745 1/2

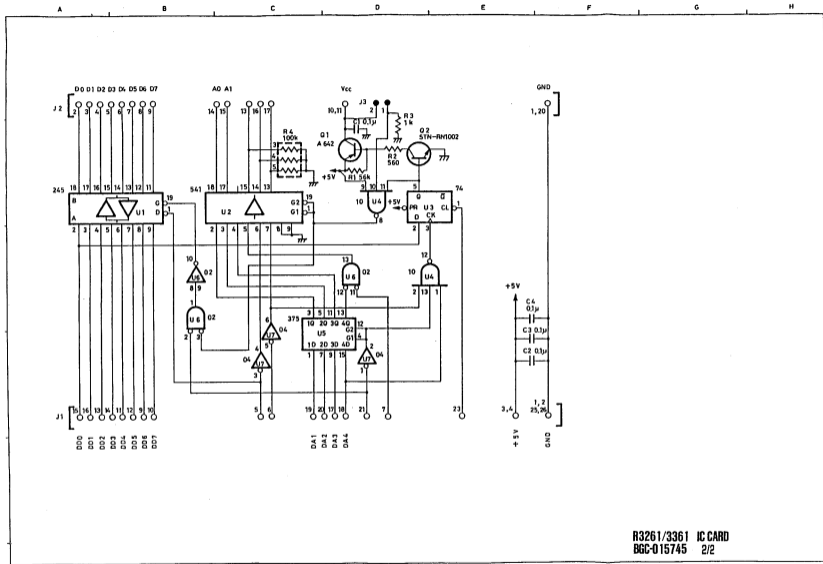

R3261/3361 IC CARD
BGC-015745 2/2

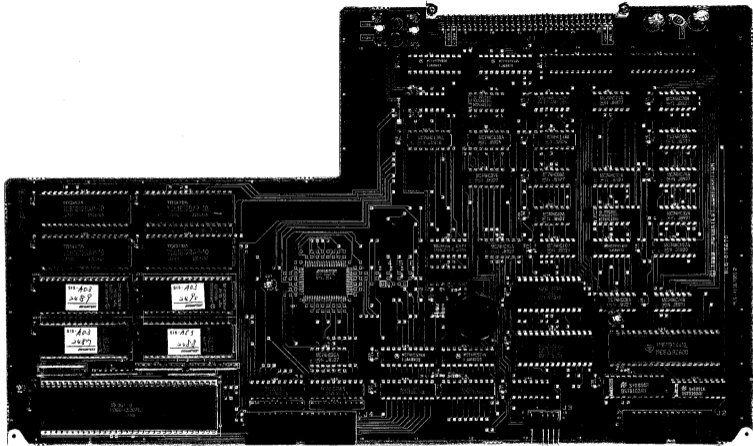

PARTS LOCATION
CONTROL
BLQ-015670

1. DIAGRAMS ILLUSTRATION

1-1 SYMBOLS REFERENCE DESIGNATORS

1) RESISTOR

11) RAY-AL3RPM8



SYMBOL



CIRCUIT



PART

2) IC PIN NAME (PIN-NAME OF NEGATIVE LOGIC ARE DISPLAYED BY SMALL LETTER)



12) RRE-D0K8B15



SYMBOL



CIRCUIT

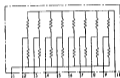

PART

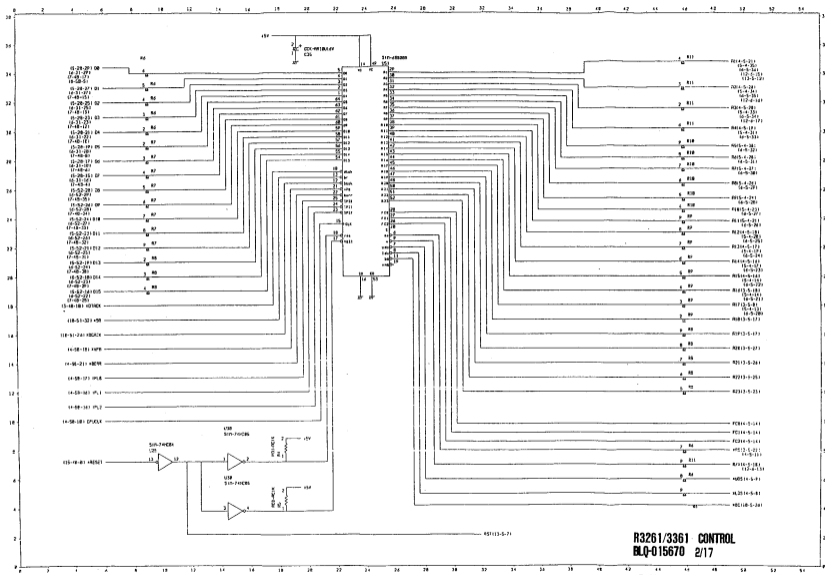

R3261/3361 CONTROL
BLQ-015670 2/17

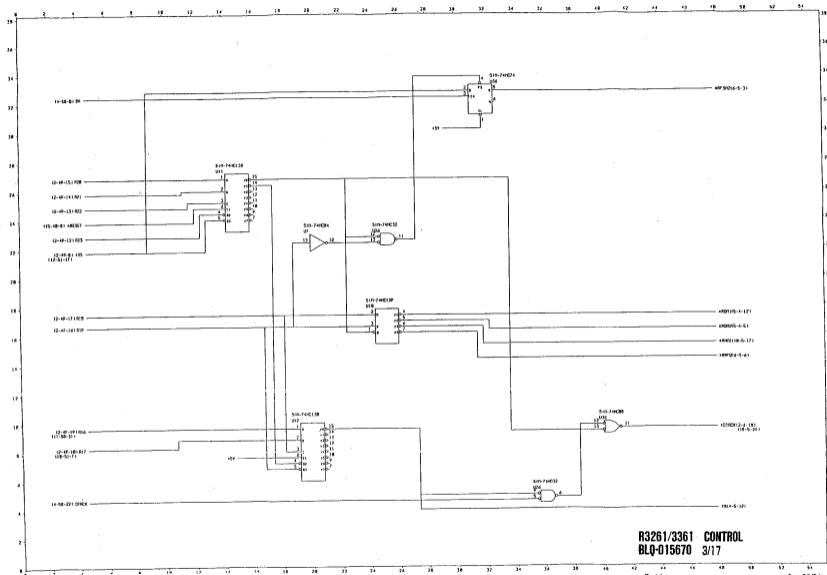

R3261/3361 CONTROL
BLQ-015670 3/17

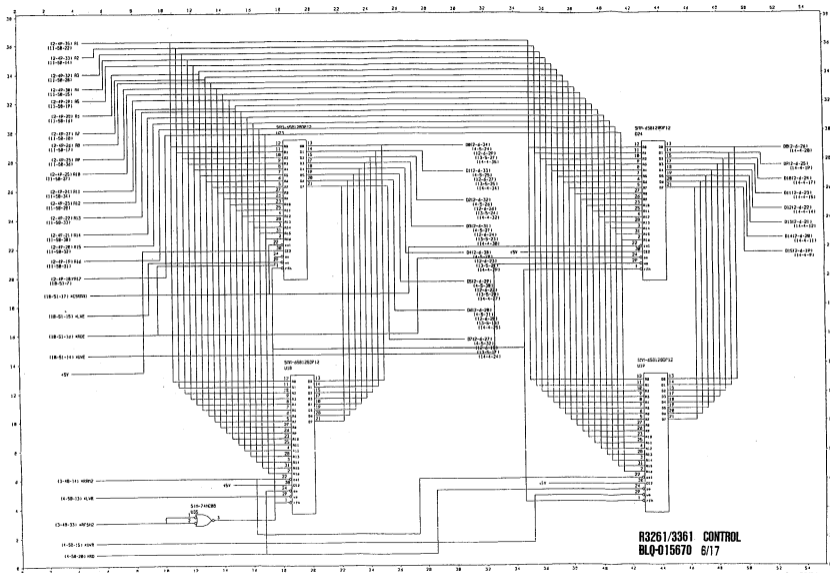

R3261/3361 CONTROL
BLQ-015670 6/17

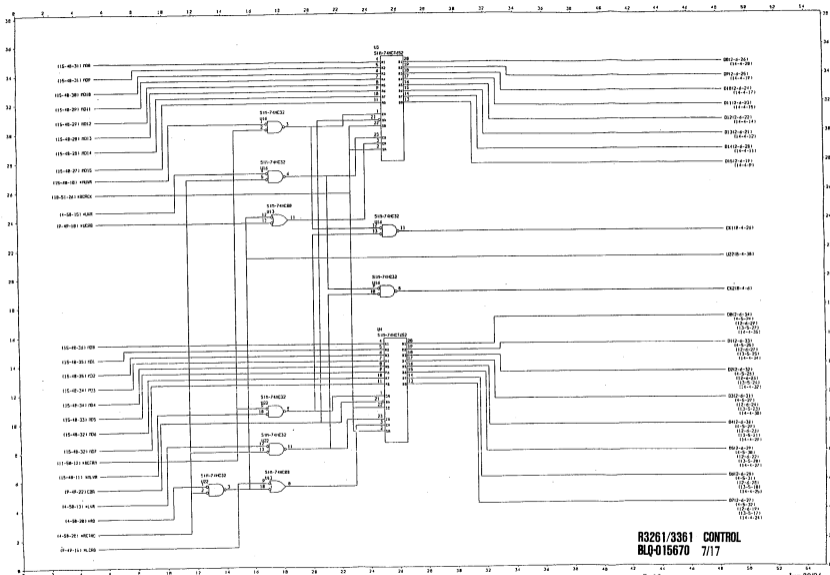

R3261/3361 CONTROL
BLQ-015670 7/17

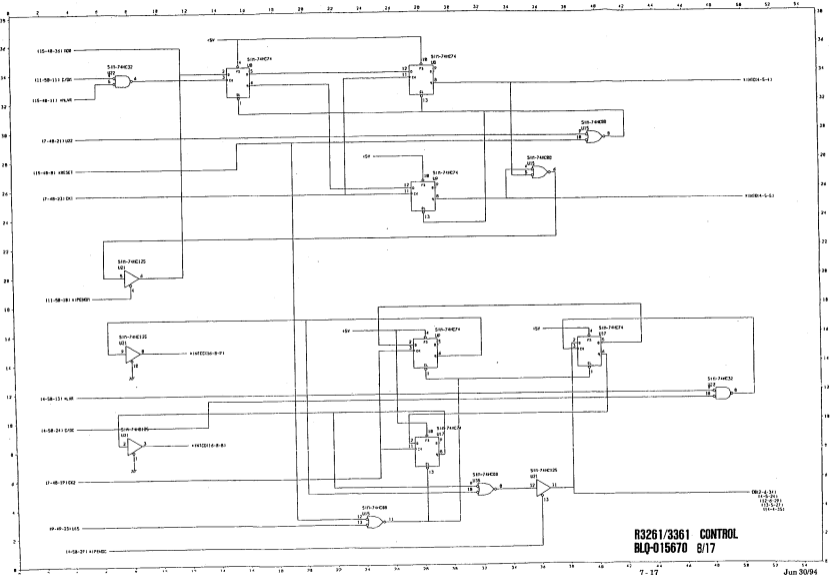

R3261/3361 CONTROL
BLQ-015670 8/17

002-4-31
 00-0-201
 112-0-291
 113-0-211
 114-0-251

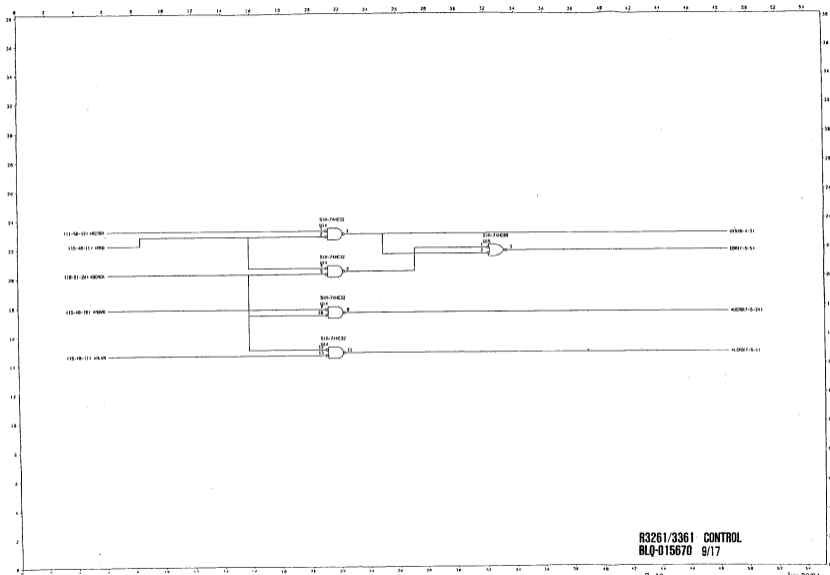

R3261/3361 CONTROL
 BLQ-015670 9/17

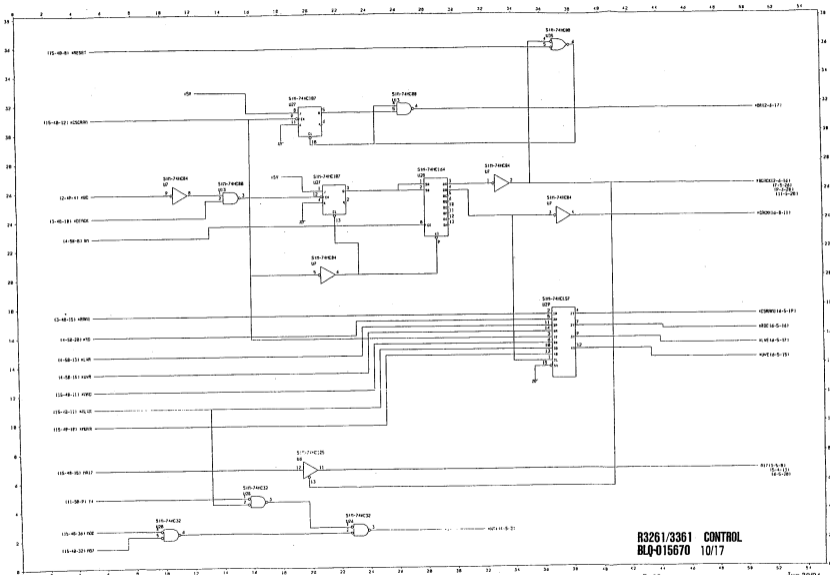

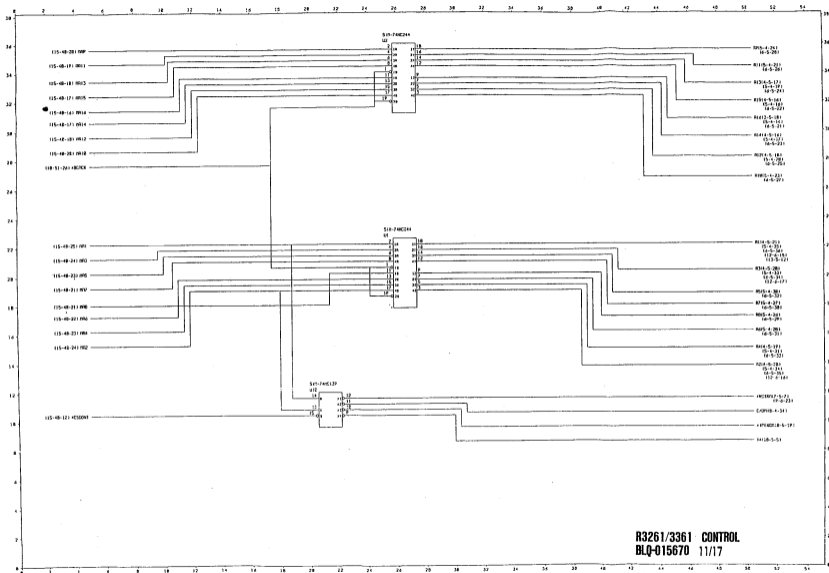

R3261/3361 CONTROL
BLQ-015670 11/17

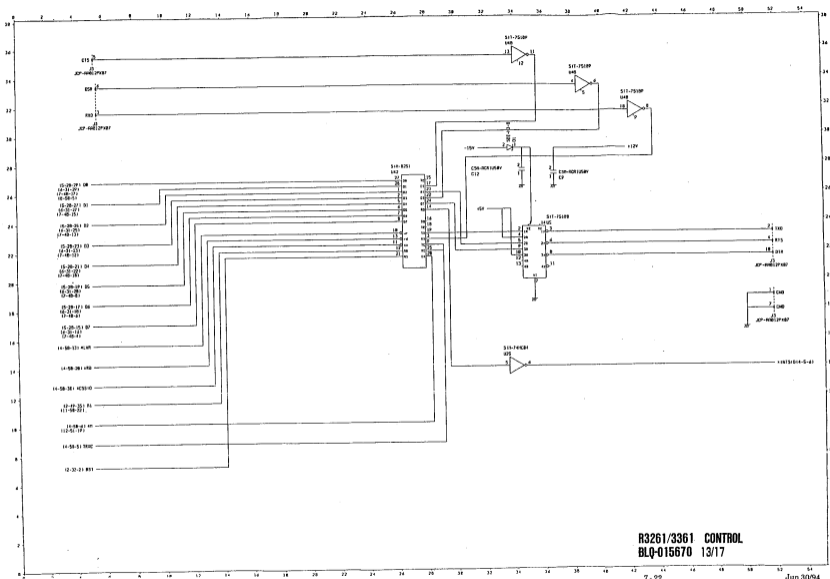

- 15-28-291 08
- 17-31-291
- 17-08-291
- 16-58-291
- 15-28-291 01
- 17-30-291
- 17-08-291
- 15-28-291 03
- 17-31-291
- 17-08-291
- 15-28-291 04
- 17-30-291
- 17-08-291
- 15-28-291 05
- 17-31-291
- 17-08-291
- 15-28-291 06
- 17-31-291
- 17-08-291
- 15-28-291 07
- 17-30-291
- 17-08-291
- 14-58-291 08
- 14-58-291 09
- 14-58-291 10
- 14-58-291 11
- 14-58-291 12
- 14-58-291 13
- 14-58-291 14
- 14-58-291 15
- 14-58-291 16
- 14-58-291 17
- 14-58-291 18
- 14-58-291 19
- 14-58-291 20
- 14-58-291 21
- 14-58-291 22
- 14-58-291 23
- 14-58-291 24
- 12-30-21 801

R3261/3361 CONTROL
BLQ-015670 13/17

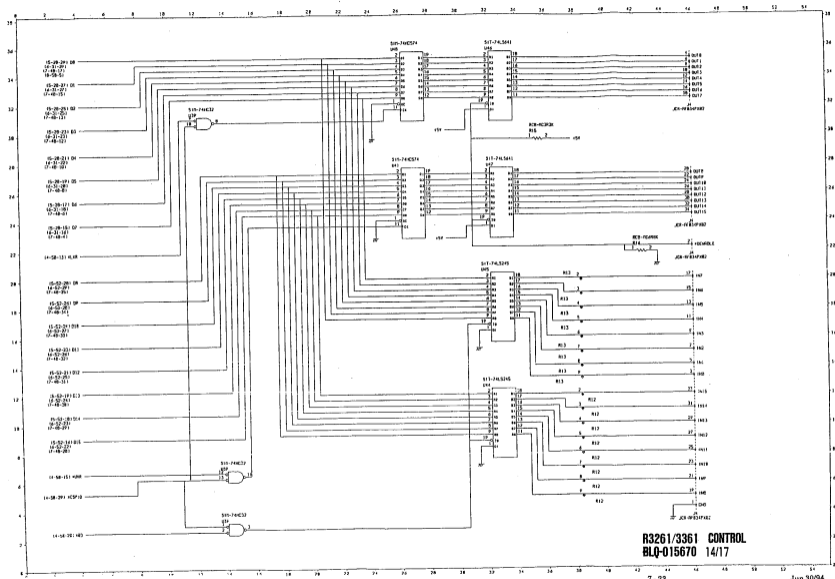

R3261/3361 CONTROL
BLQ-015670 14/17

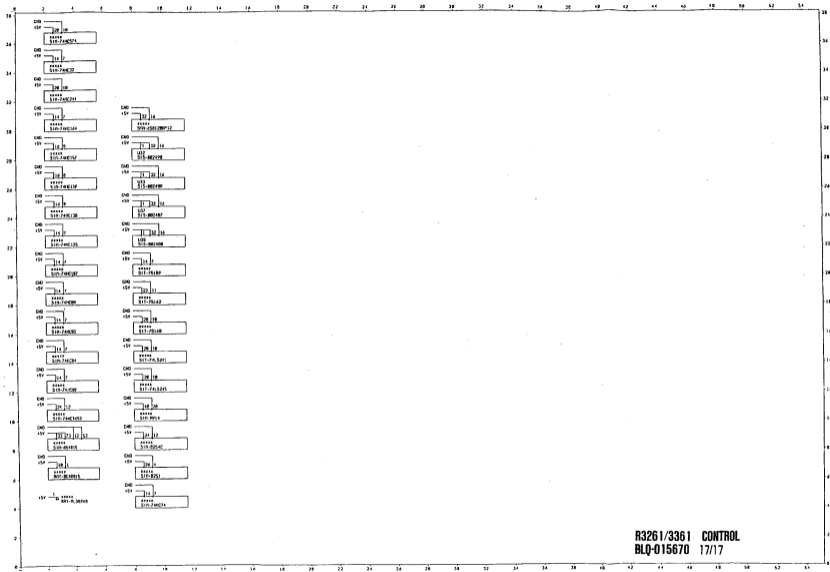

R3261/3361 CONTROL
BLQ-015670 17/17

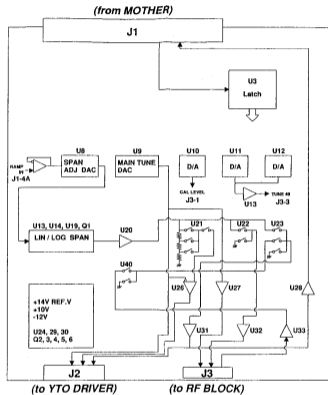

**CIRCUIT LAYOUT
RF CONTROL
BLL-015672**

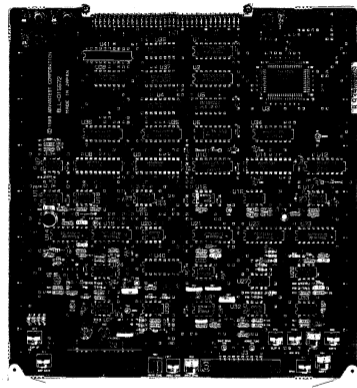

PARTS LOCATION
RF CONTROL
BLL-015872

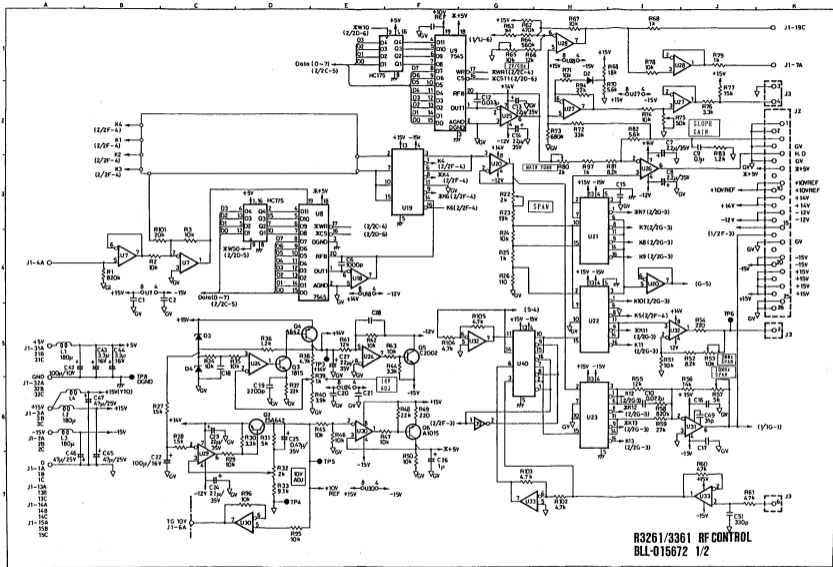

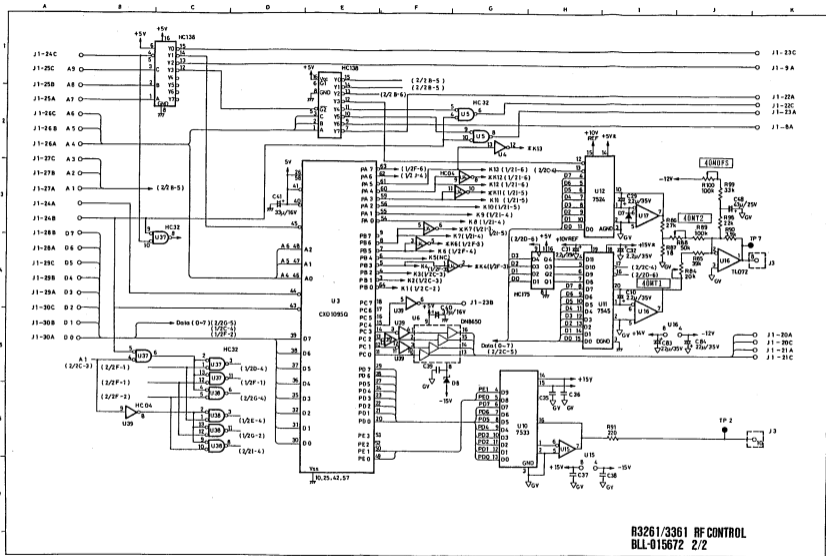

R3261/3361 RF CONTROL
BLI-015672 2/2

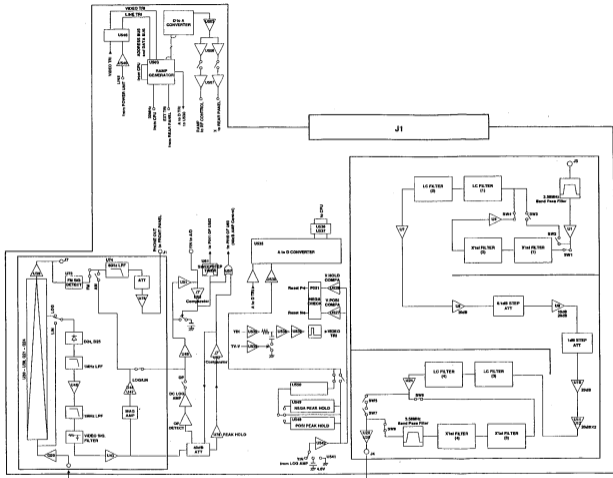

CIRCUIT LAYOUT
IF SECTION
BLQ-015668

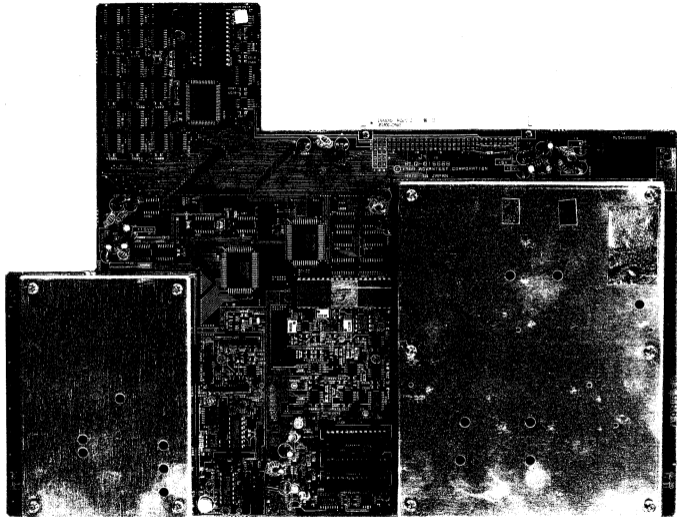

PARTS LOCATION
IF SECTION
BLQ-015688

1. DIAGRAMS ILLUSTRATION

1-1 SYMBOLS REFERENCE DESIGNATORS

1) IC PIN NAME (PIN-NAME OF NEGATIVE LOGIC ARE
DISPLAYED BY SMALL LETTER)



R3261/3361 IF
BLQ-015668 1/38

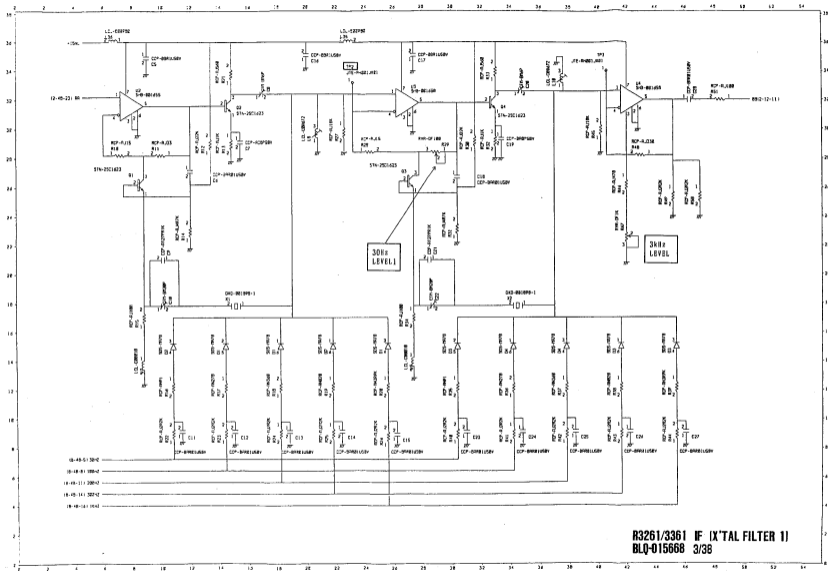

R3261/3361 IF (X'TAL FILTER 1)
BLQ-015668 3/38

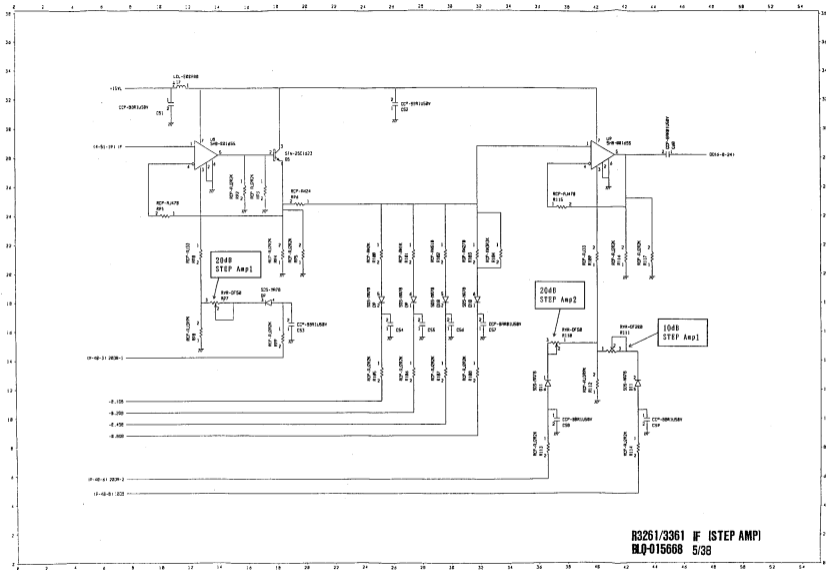

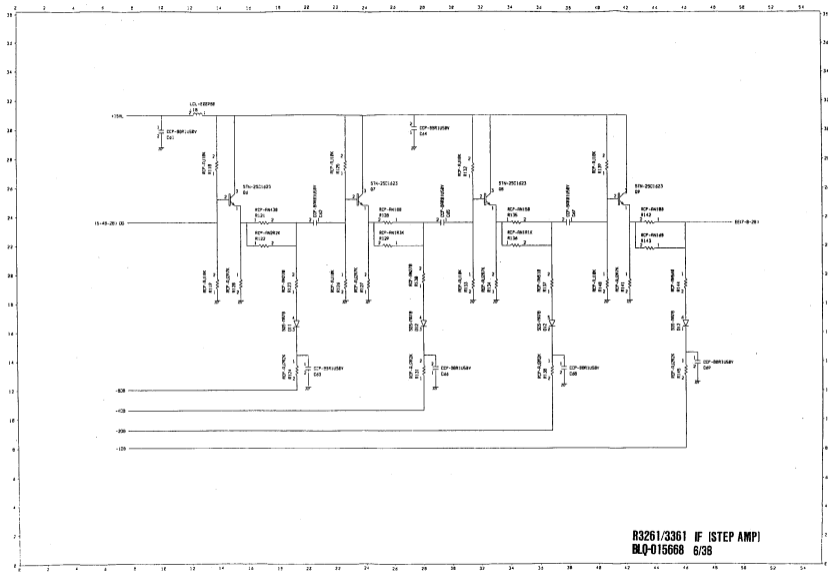

R3261/3361 IF (STEP AMP)
 BLQ-015668 6/38

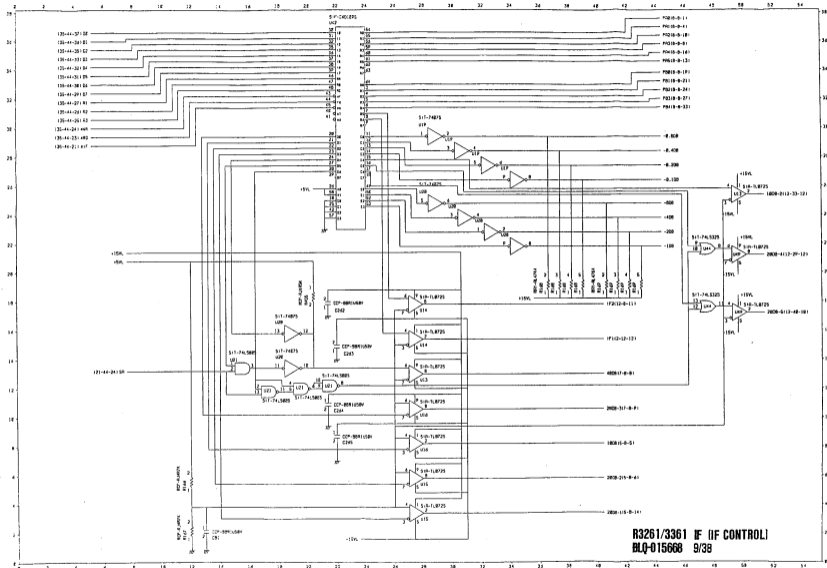

R3261/3361 IF (IF CONTROL)
BLQ-01566B 9/38

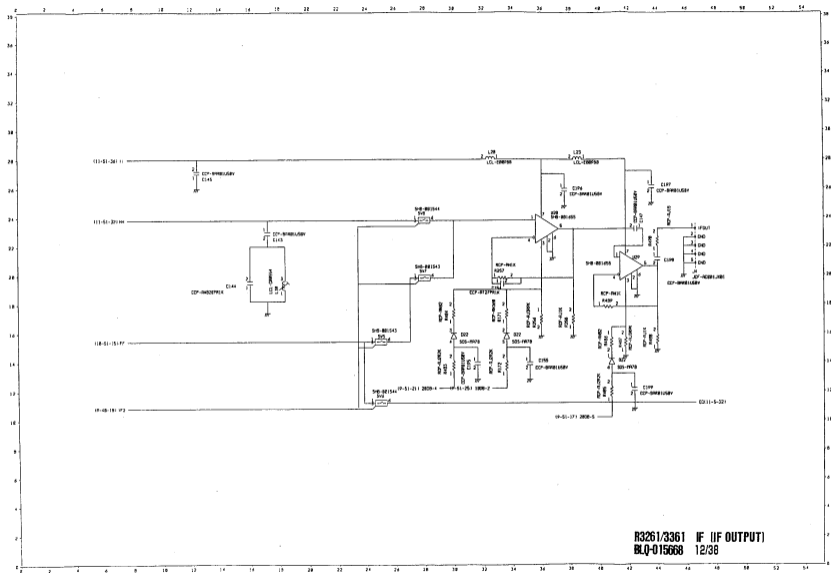

R3261/3361 IF (IF OUTPUT)
 BLQ-015668 12/38

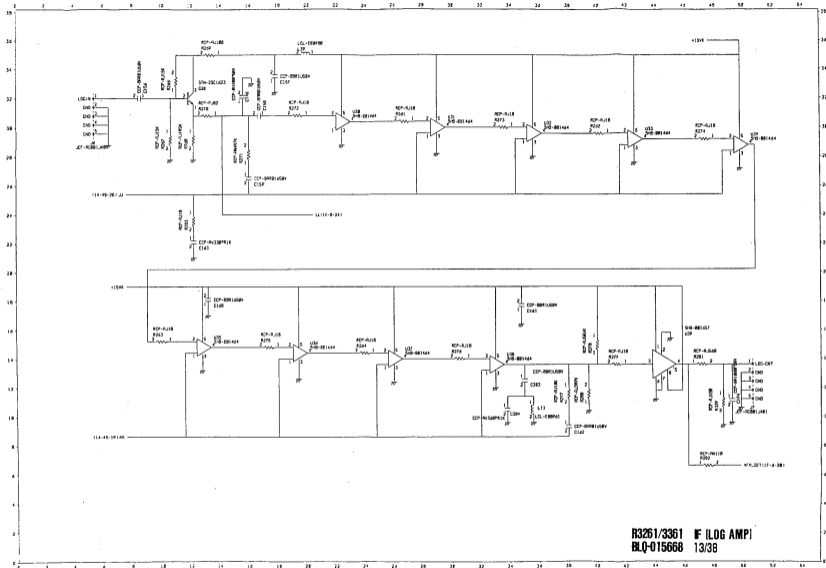

R3261/3361 F (LOG AMP)
BLQ-015668 13/38

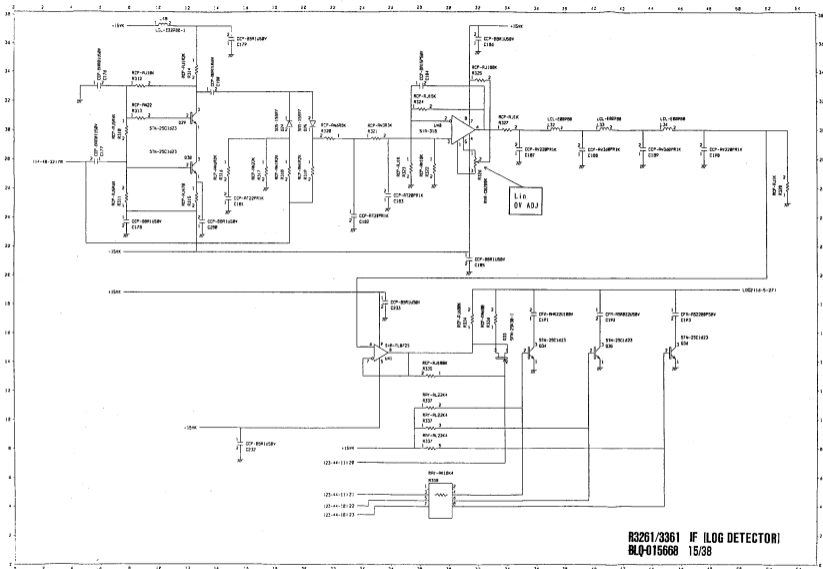

R3261/3361 IF (LOG DETECTOR)
 BLQ-015668 15/38

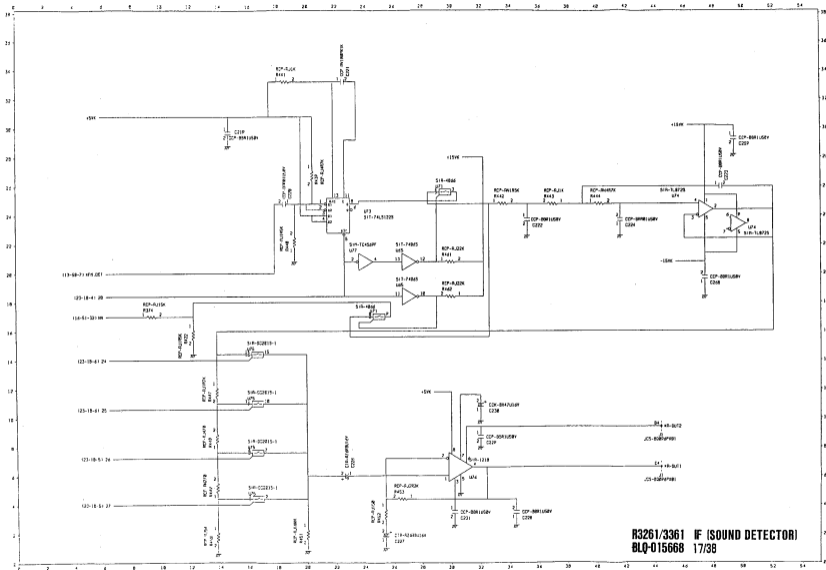

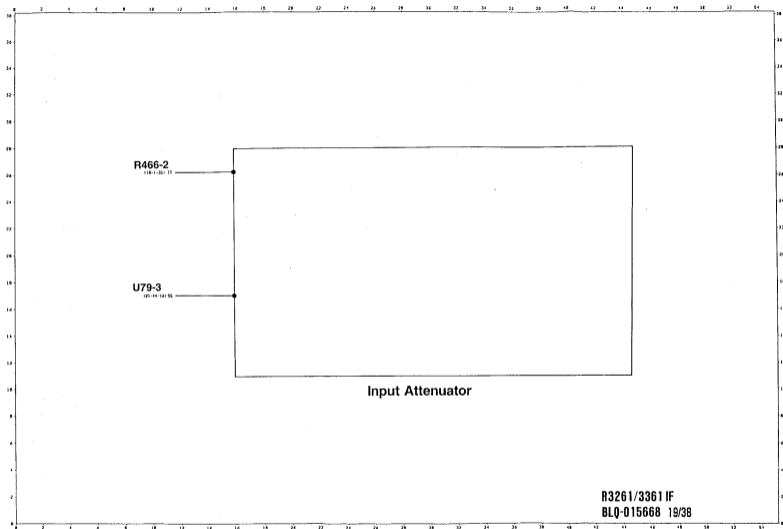

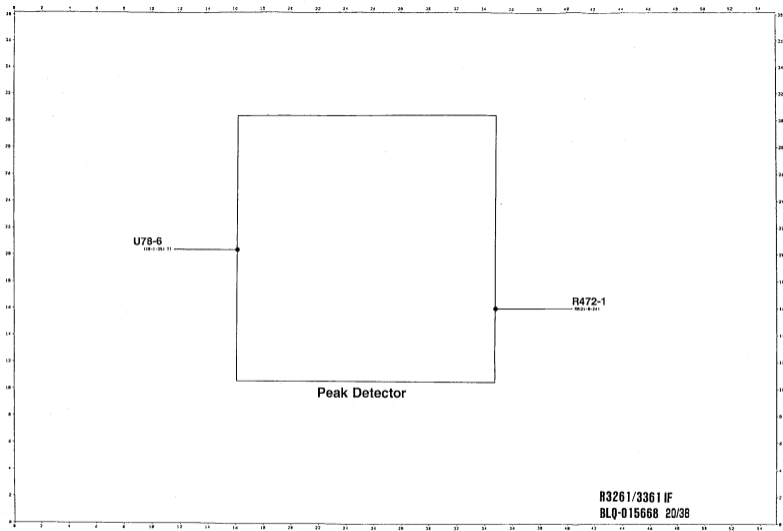

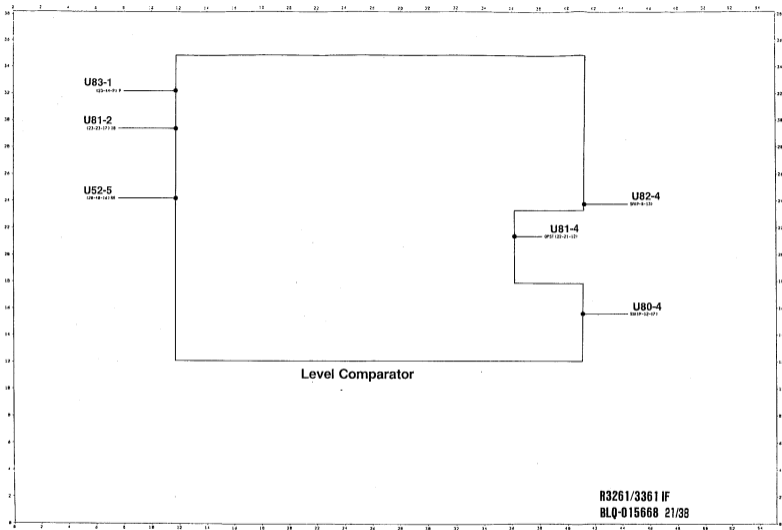

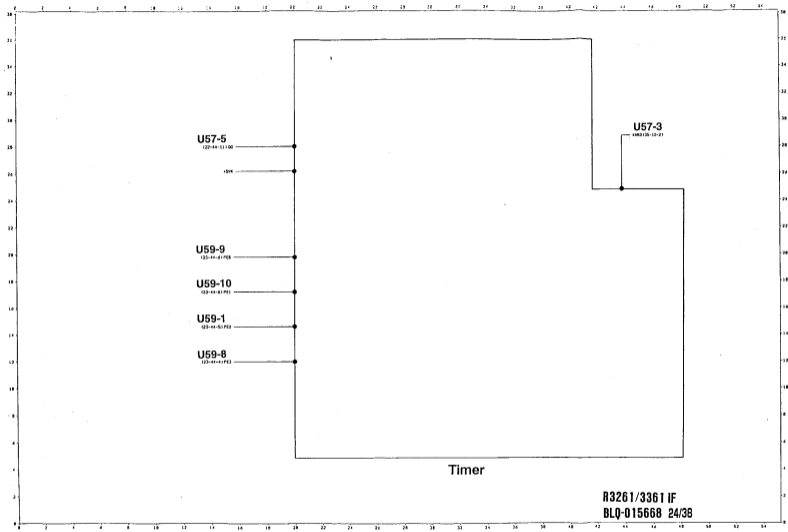

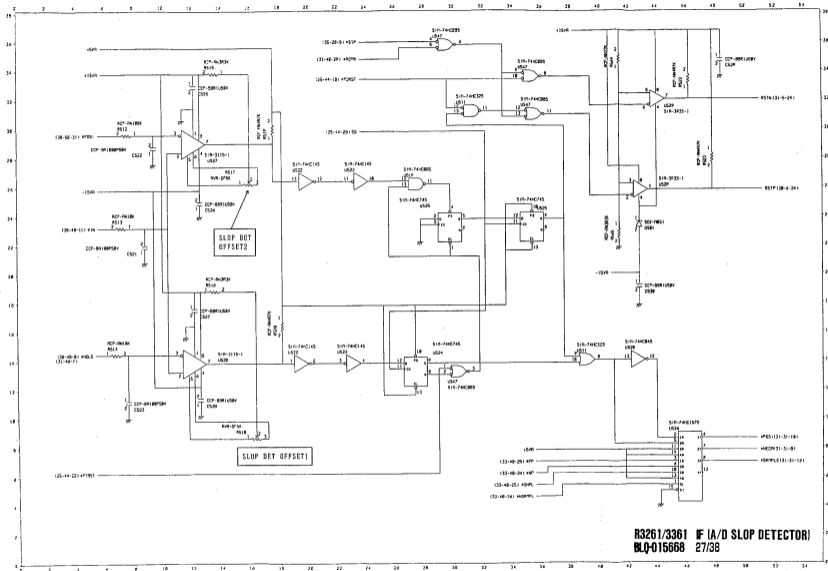

R3261/3361 IF IA/D SLOP DETECTOR
 BLQ-015668 27/38

P11 - P23

U548

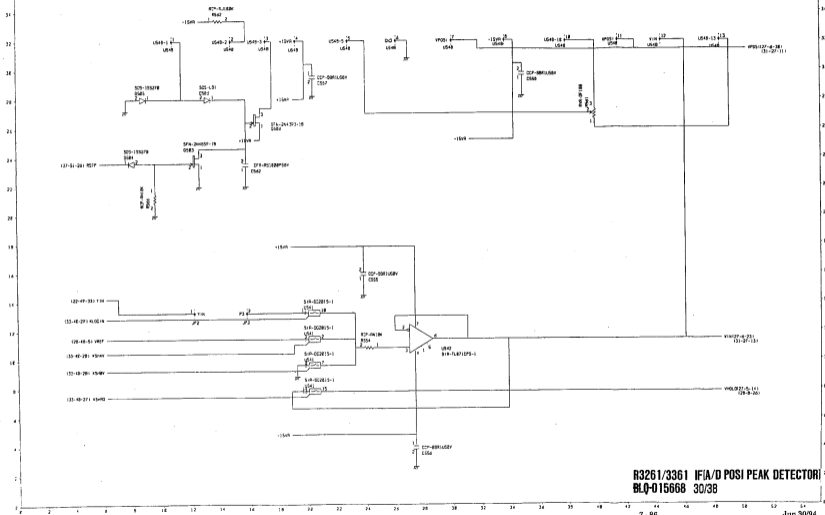

R3261/3361 IFIA/D POSI PEAK DETECTOR
BLQ-015668 30/38

P51 - P63
U550

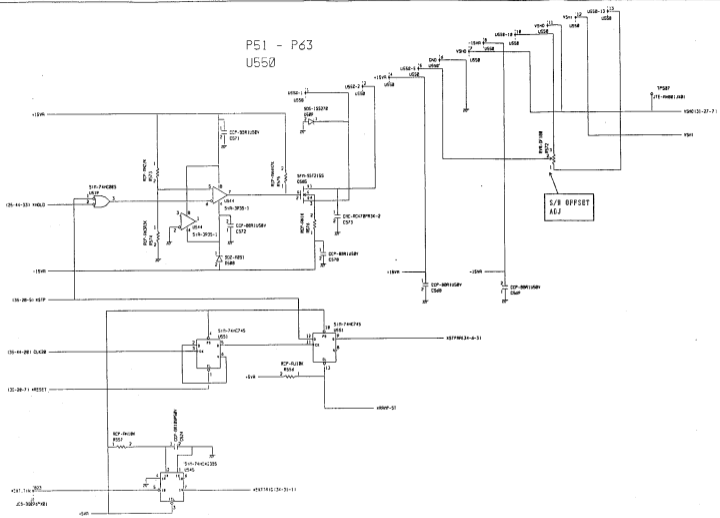

R3261/3361 IF (A/D SAMPLE HOLD
BLQ-015668 32/38 DETECTOR)

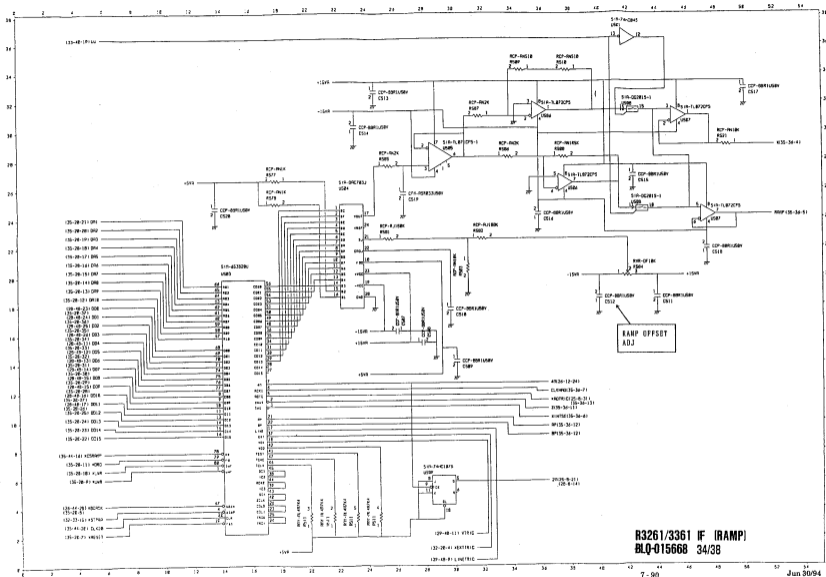

R3261/3361 IF (RAMP)
BLQ-015668 34/38

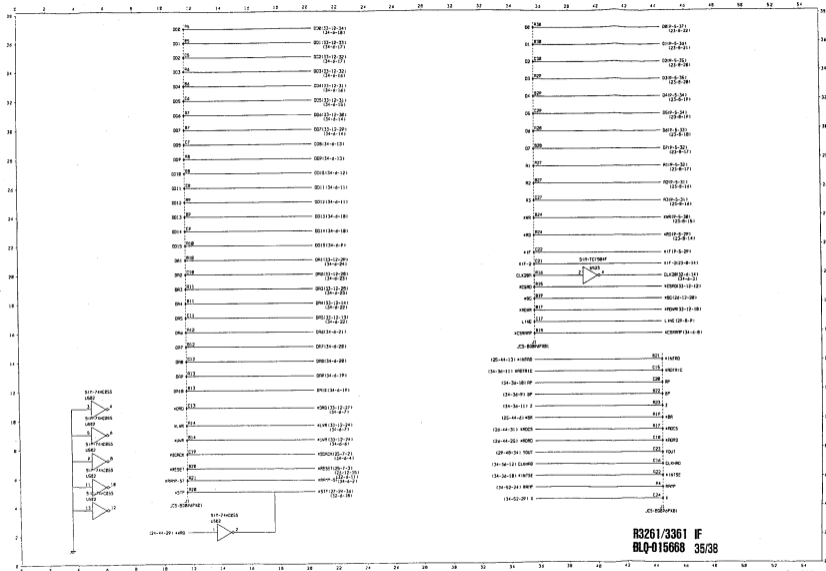

R3261/3361 IF
BLQ-015668 35/38

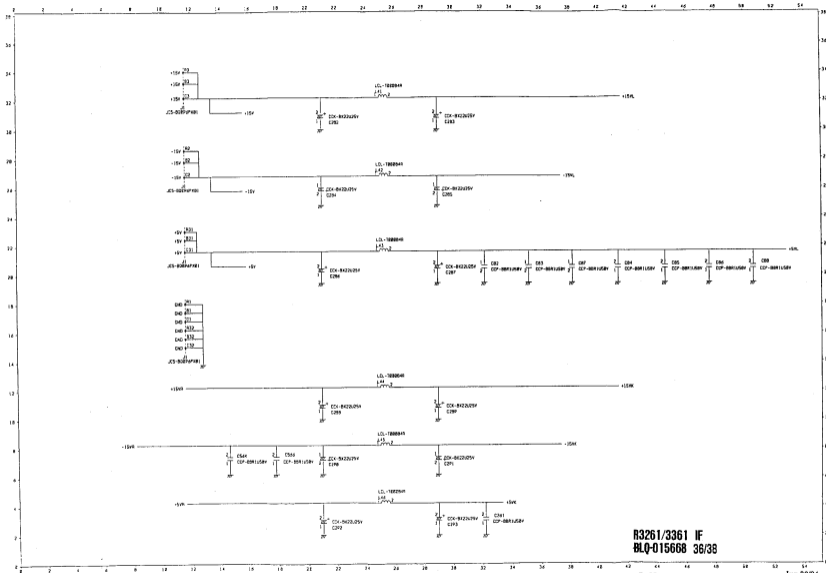

R3261/3361 IF
BLQ-015668 38/38

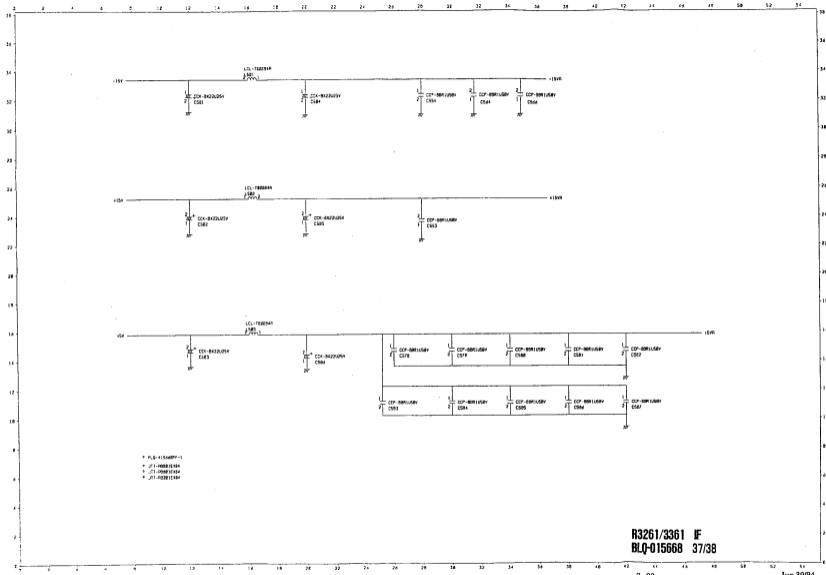

- BLQ-015668F-1
- J1-19880104
- J1-20880104
- J1-19880104

R3261/3361 IF
BLQ-015668 37/38

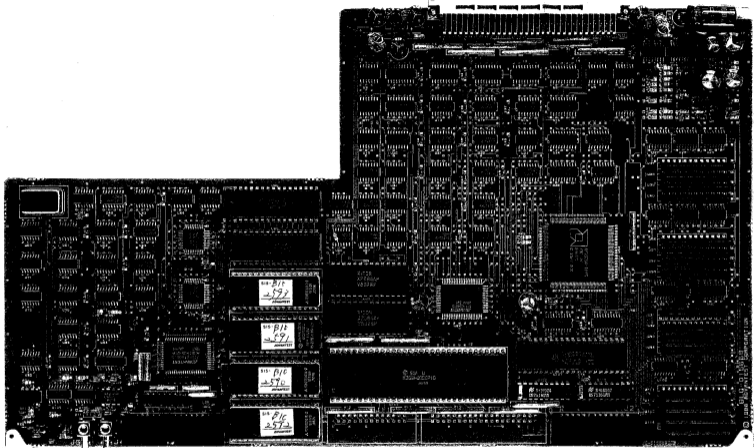

PARTS LOCATION
CPU
BLQ-015669

1. DIAGRAMS ILLUSTRATION

1-1 SYMBOLS REFERENCE DESIGNATORS

1) RESISTOR

(1) 89Y-AL3RKB



SYMBOL



CIRCUIT



PART

2) IC PIN NAME (PIN-NAME OF NEGATIVE LOGIC ARE DISPLAYED BY SMALL LETTER)



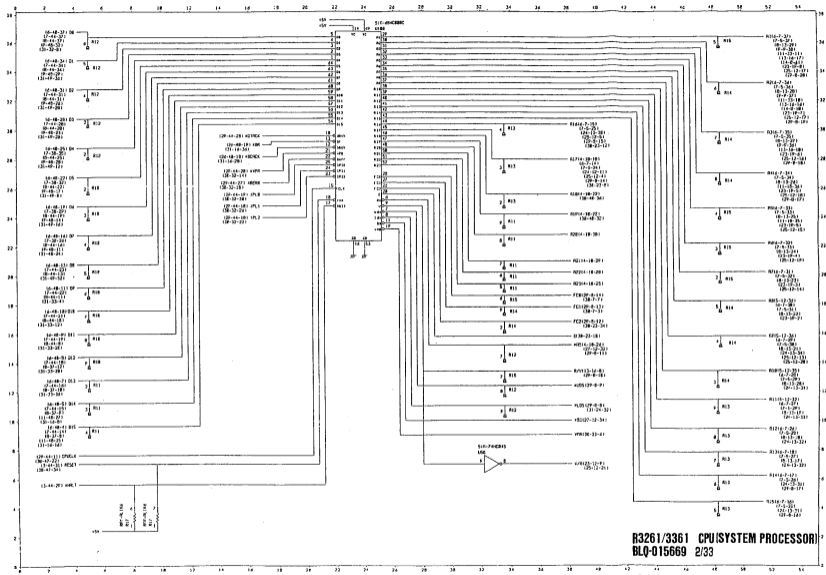

R3261/3361 CPU(SYSTEM PROCESSOR)
BLQ-015669 2/33

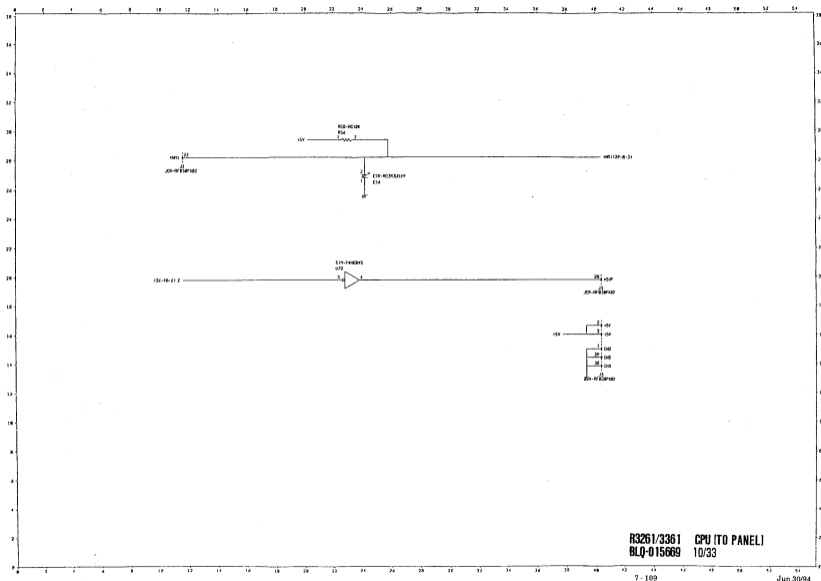

R3261/3361 CPU (I/O PANEL)
 BLQ-015669 10/33

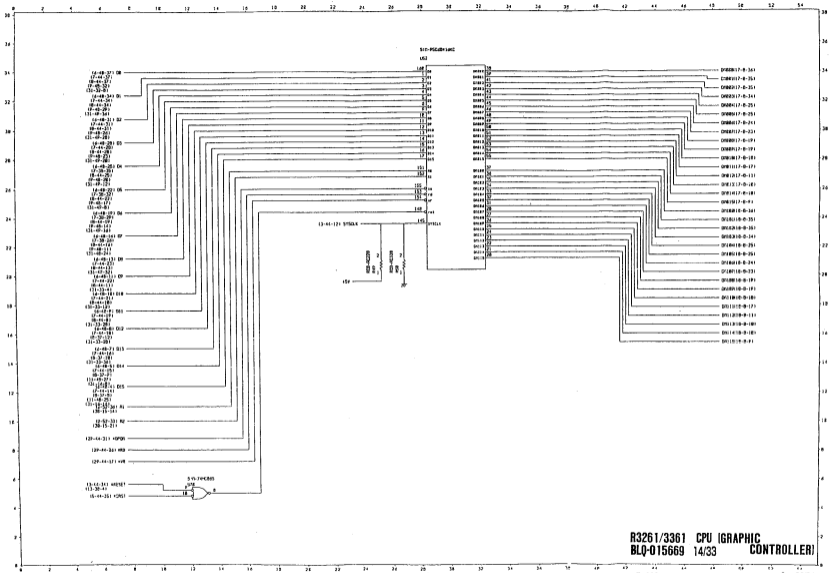

R3261/3361 CPU (GRAPHIC
 BLQ-015669 14/33 CONTROLLER)

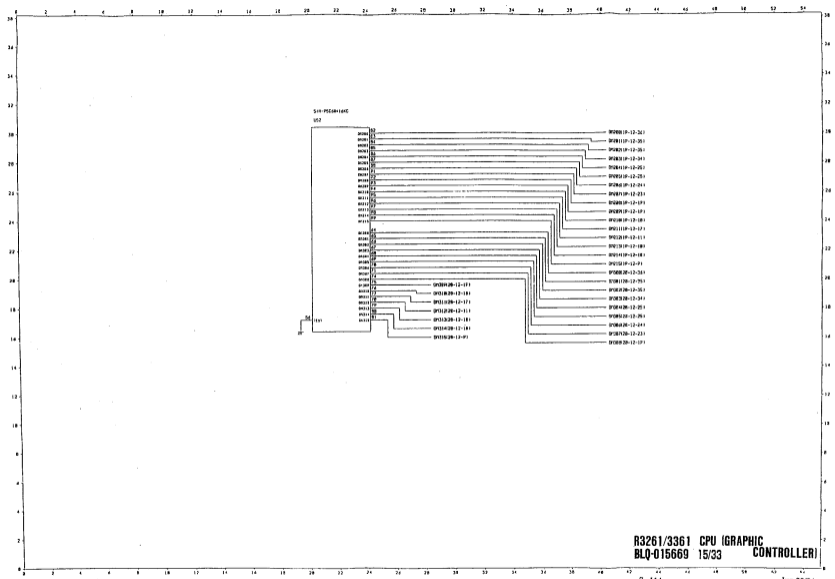

R3261/3361 CPU (GRAPHIC
BLQ-015669 15/33 CONTROLLER)

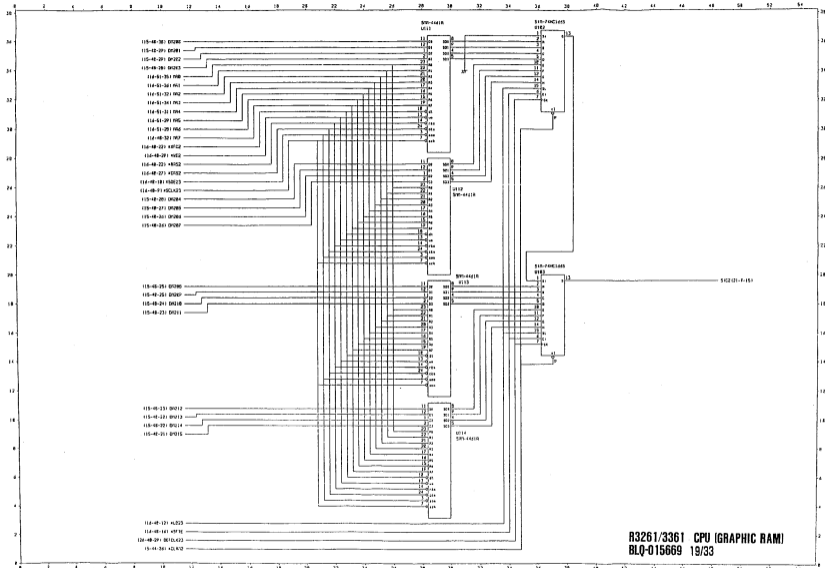

R3261/3361 CPU (GRAPHIC RAM)
 BLQ-015669 19/33

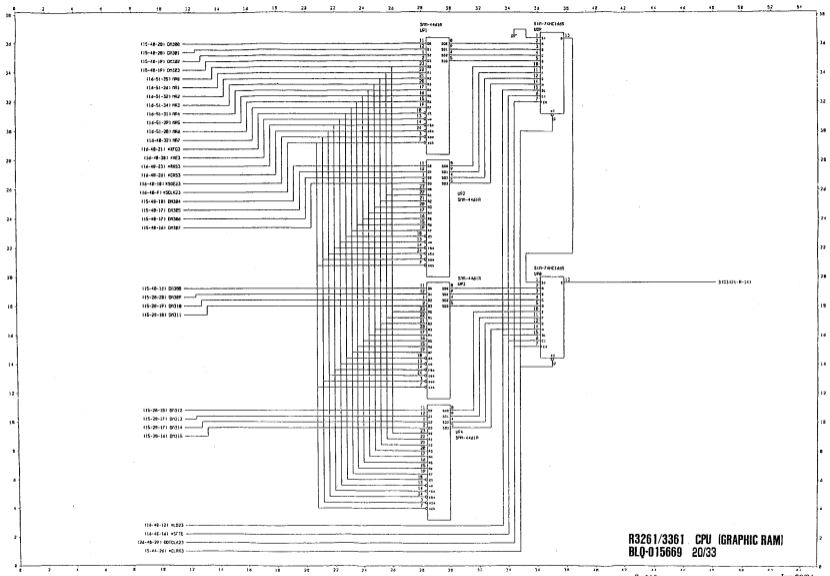

R3261/3361 CPU (GRAPHIC RAM)
BLQ-015669 20/33

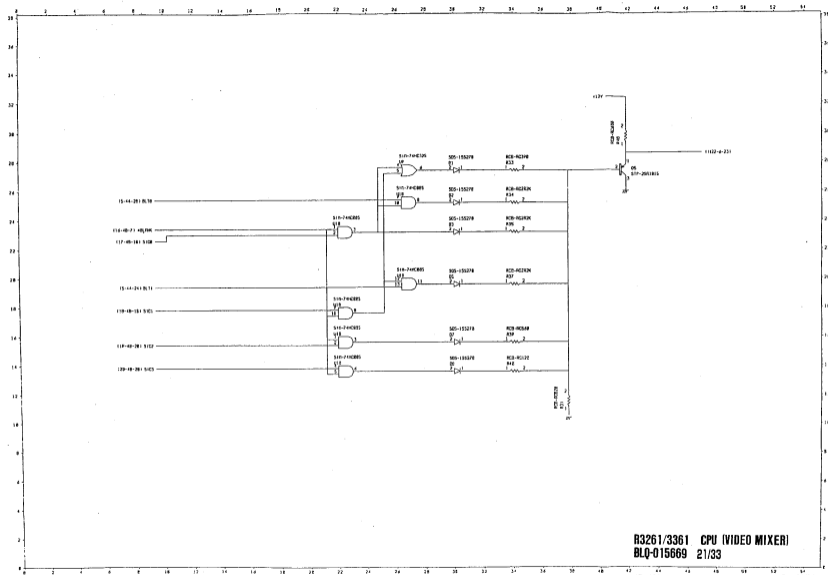

R3261/3361 CPU (VIDEO MIXER)
BLQ-015669 21/33

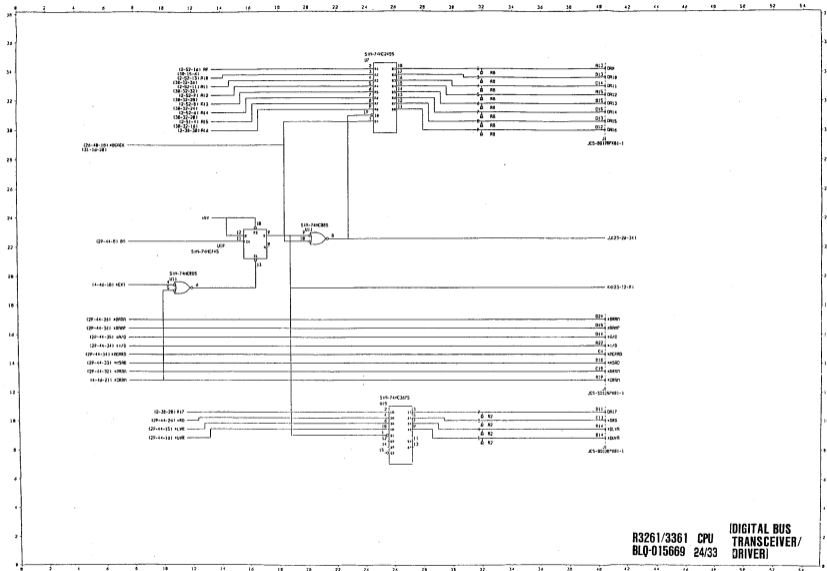

R3261/3361 CPU
BLQ-015669 24/33

DIGITAL BUS
TRANSCIVER/
DRIVER

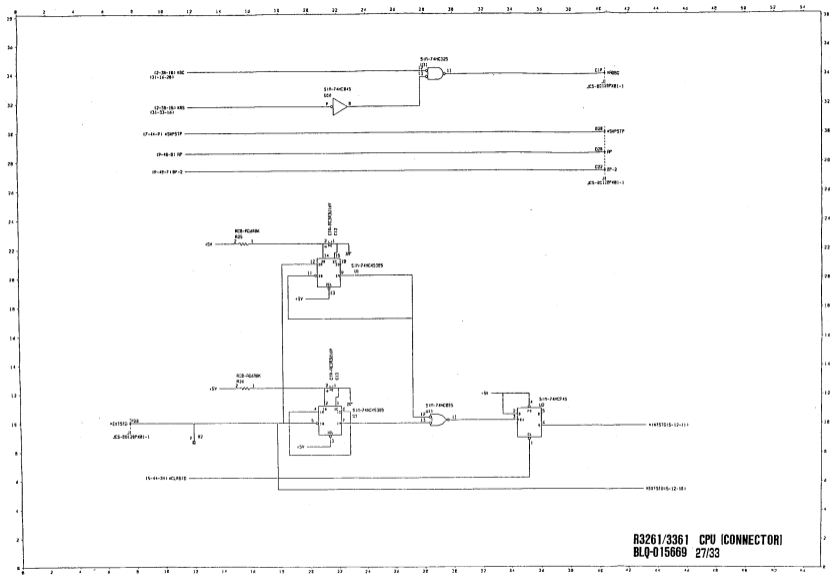

R3261/3361 CPU (CONNECTOR)
 BLQ-015669 27/33

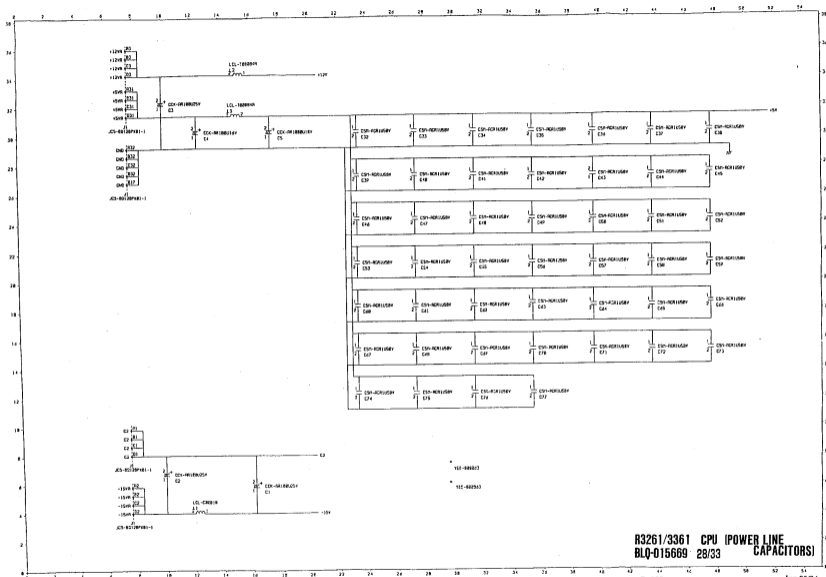

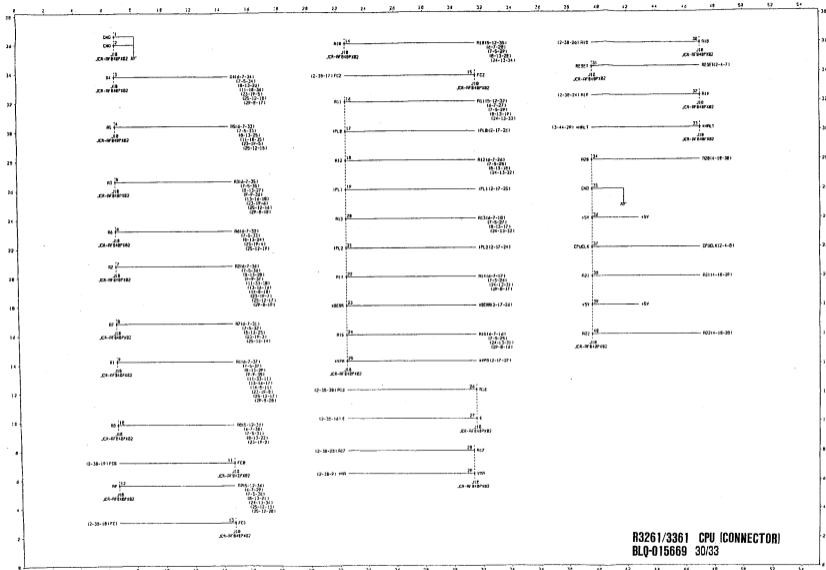

R3261/3361 CPU (CONNECTOR)
BLQ-015669 30/33

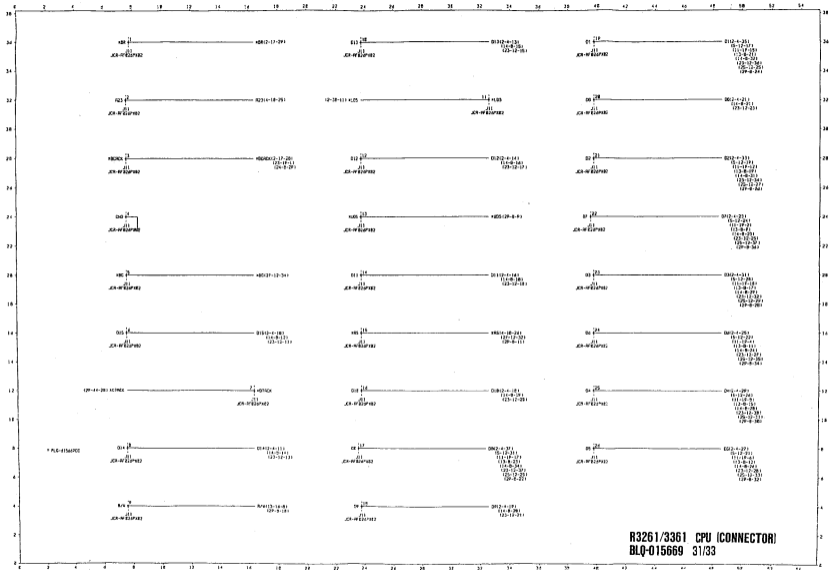

R3261/3361 CPU (CONNECTOR)
 BLQ-015669 31/33

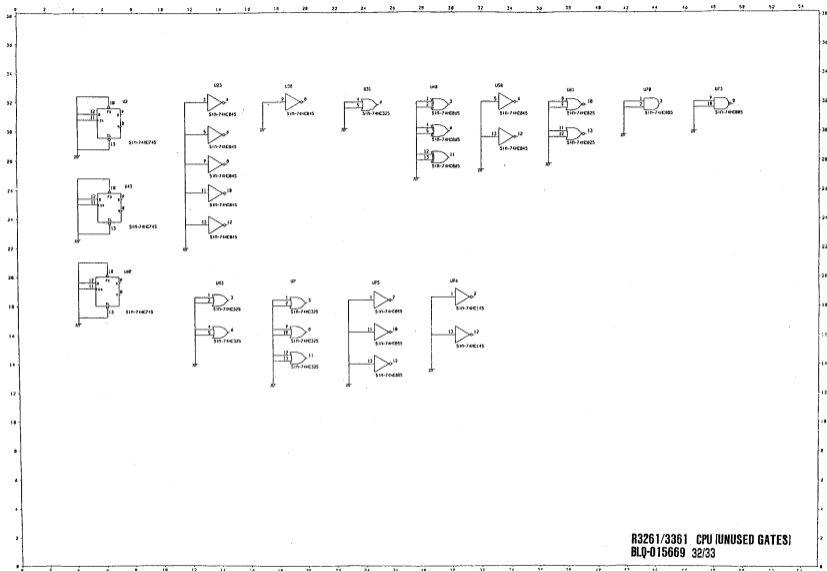

R3261/3361 CPU (UNUSED GATES)
 BLQ-015669 32/33



R3361 TG KEY
BLB-015775

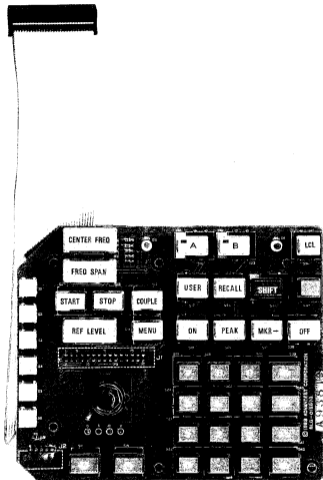

PARTS LOCATION
KEY
BLG-015673

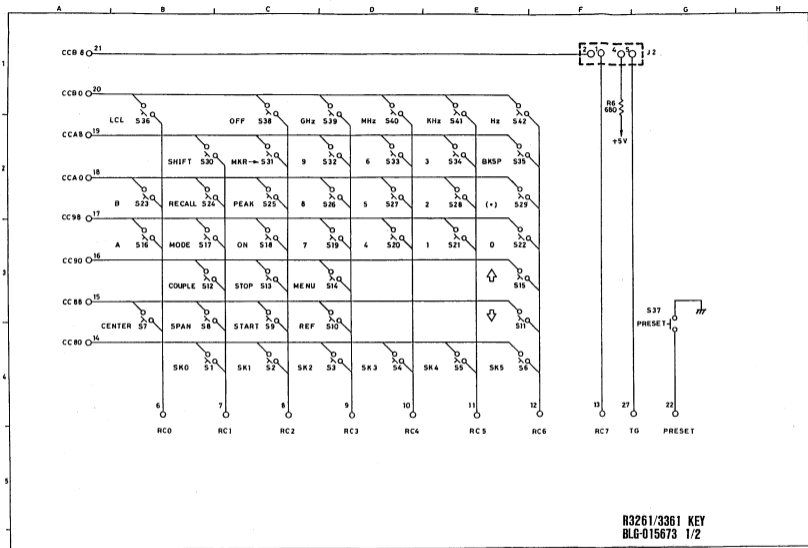

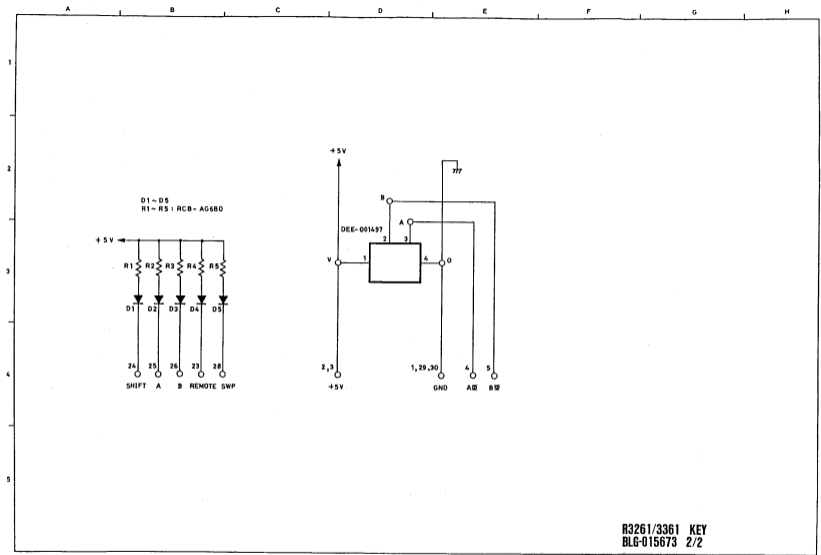

R3261/3361 KEY
 BLG-015673 2/2

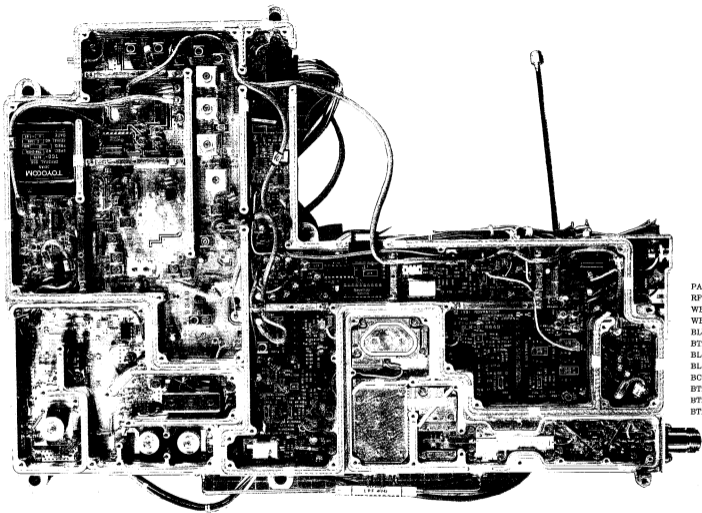

PARTS LOCATION
RP BLOCK 1
WBL-3261RF
WBL-3861RF
BLB-015646
BTB-016118
BLC-015650
BLG-015645
BCK-015649
ETB-015641
BTB-015642
ETB-015644

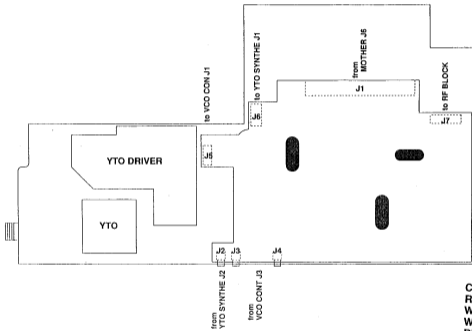

CIRCUIT LAYOUT
RF BLOCK 2
WBL-3261RF
WBL-3361RF
BLB-015727

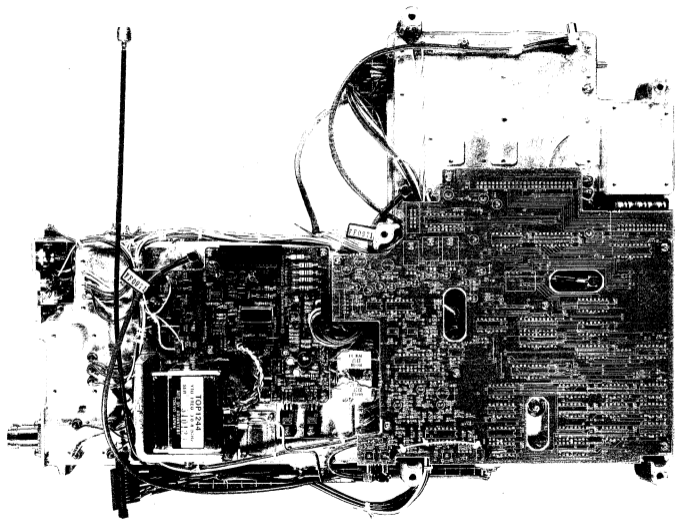

PARTS LOCATION
RF BLOCK 2
WBL-3261RF
WBL-3361RF
BLB-015727

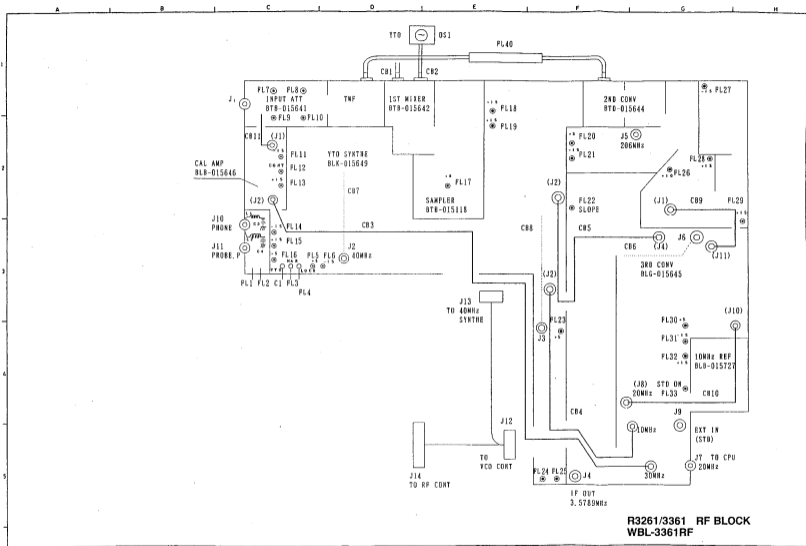

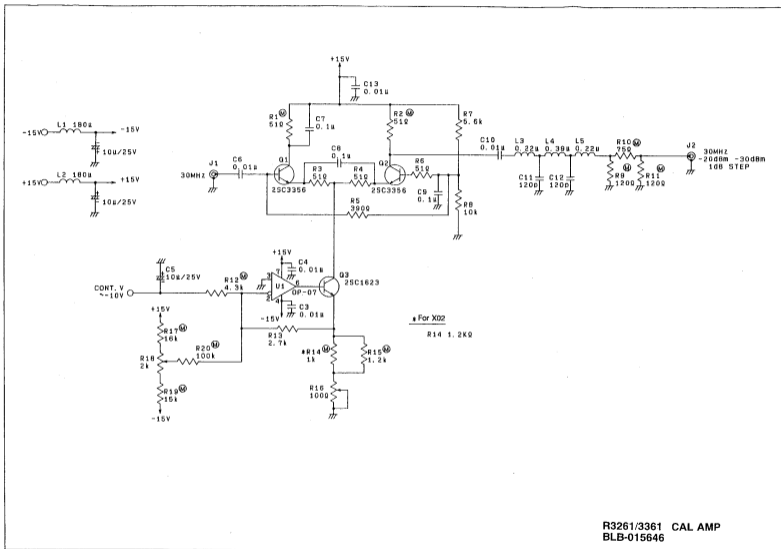

R3261/3361 CAL AMP
BLB-015646

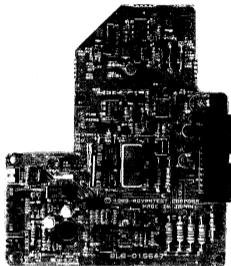

PARTS LOCATION
YTO DRIVER
BLB-015647

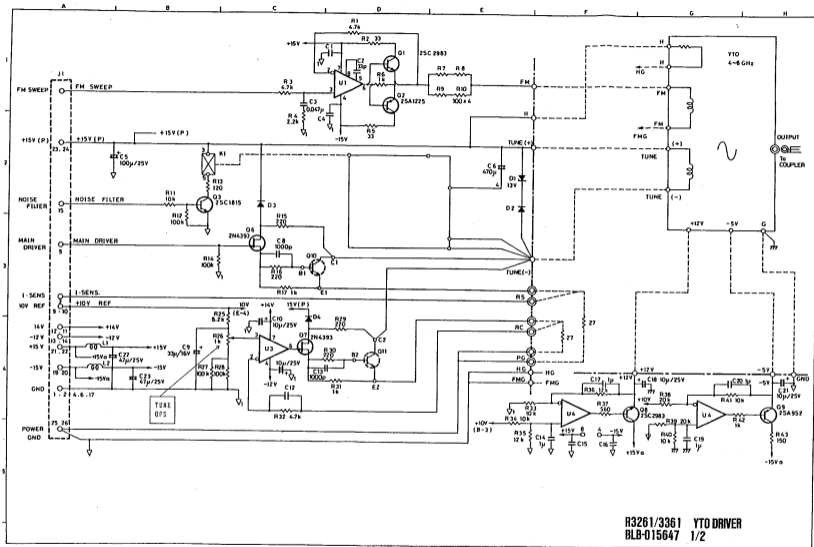

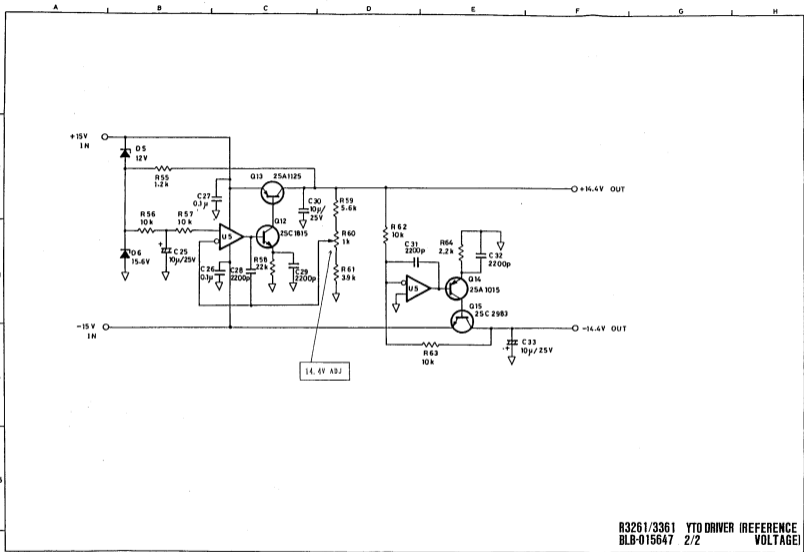

R3261/3361 YTO DRIVER (REFERENCE
BLB-015647 2/2 VOLTAGE)

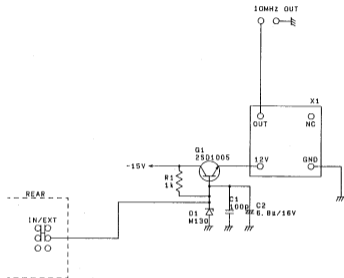

R3261/3361 10MHz REF.
BLB-015727

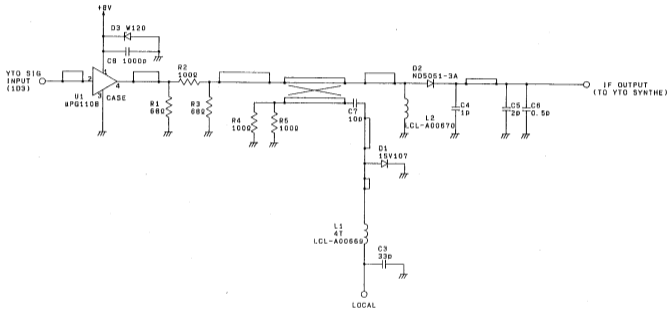

R3261/3361 SAMPLER
BTB-016118 1/2

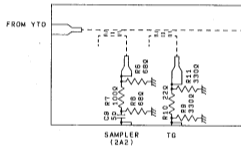

R3261/3361 SAMPLER
BTB-016118 2/2

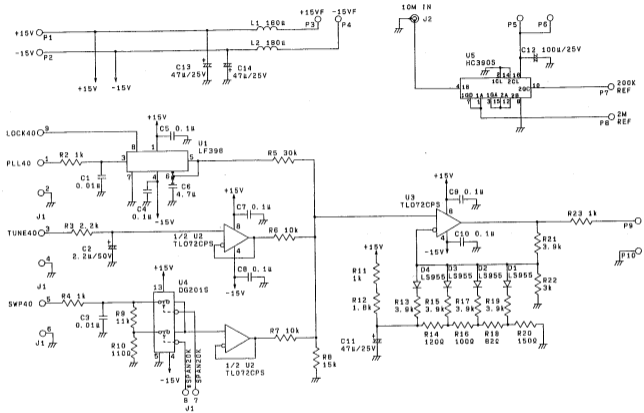

R3261/3361 VCO CONT
BLC-015650

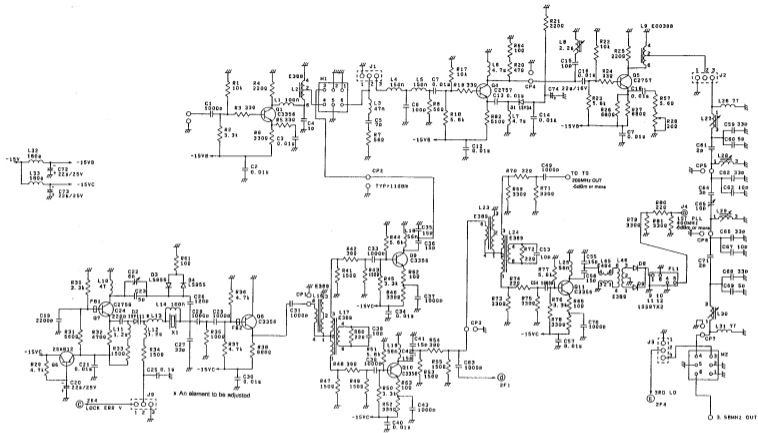

R3261/3361 3RD CONV
BLG-015645 1/3

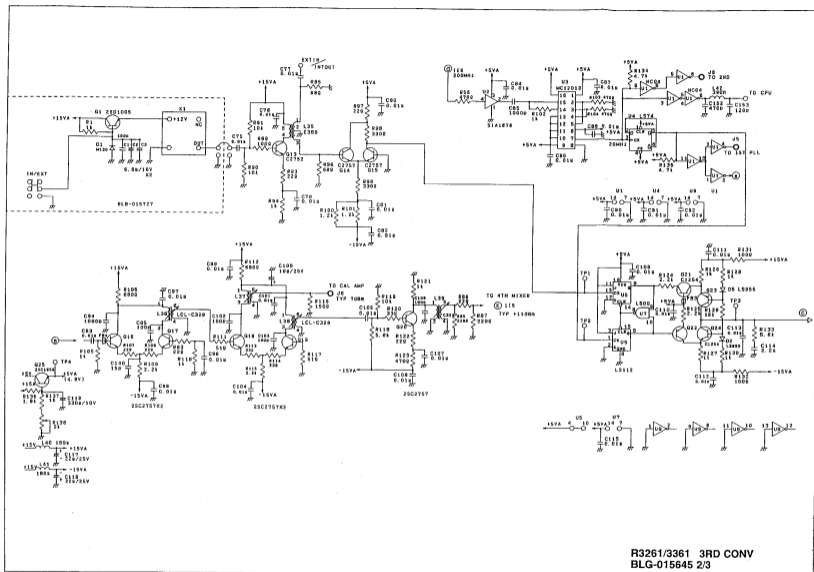

R3261/3361 3RD CONV
BLG-015645 2/3

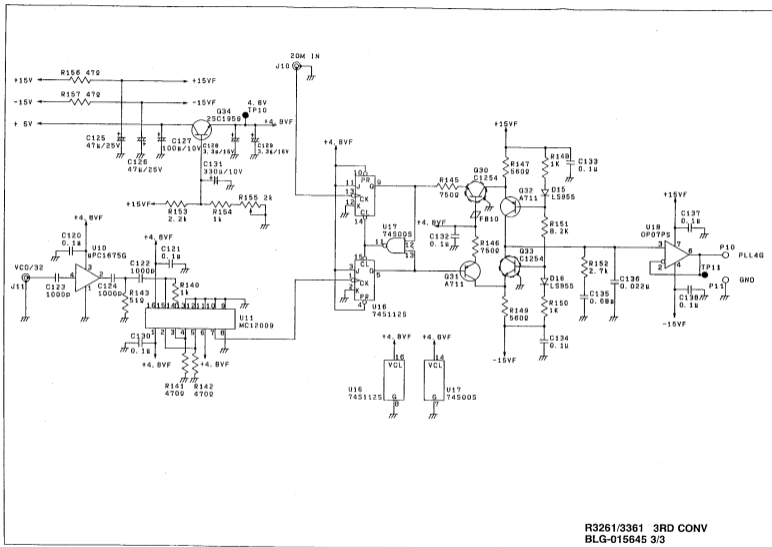

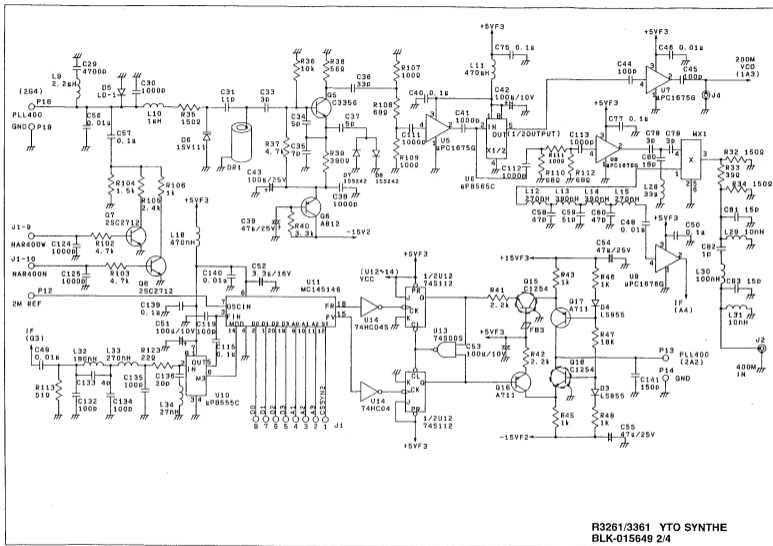

R3261/3361 YTO SYNTH
BLK-015649 2/4

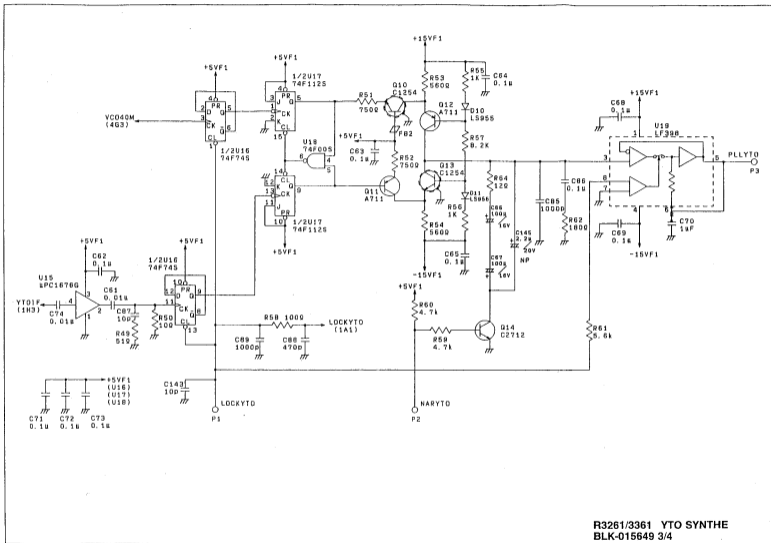

* For X02

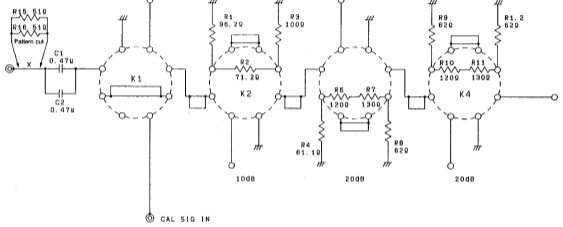

Loss (dB)	K2	K3	K4
0	0	0	0
10	-12V	0	0
20	0	-12V	0
30	-12V	-12V	0
40	0	-12V	-12V
50	-12V	-12V	-12V

CALL ON/OFF	K1
ON	0
OFF	-12V

R3261/3361 INPUT ATT
BTB-01564

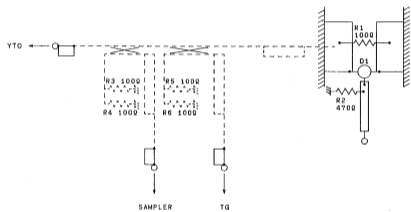

R3261/3361 1ST MIXER/COUPLER
BTB-015642

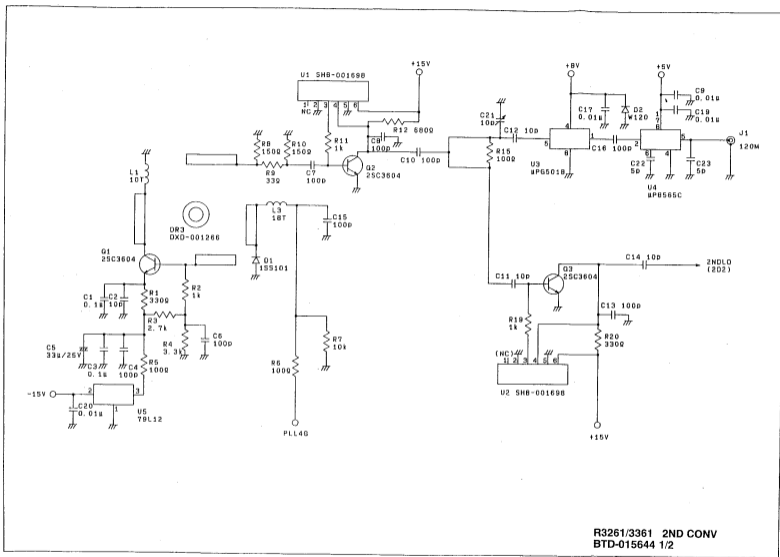

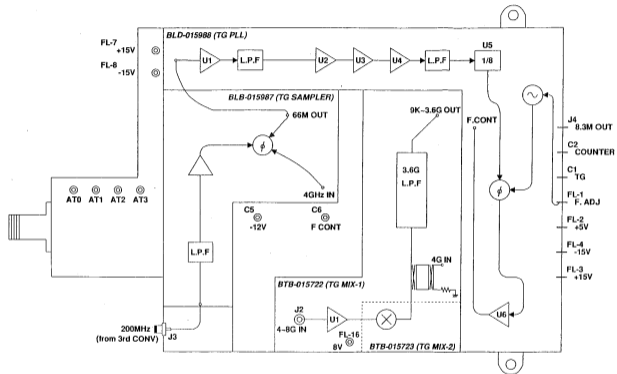

CIRCUIT LAYOUT
TG BLOCK 1
WBL-3361TG
BLB-015987
BLD-015988
BTB-015722
BTB-015723

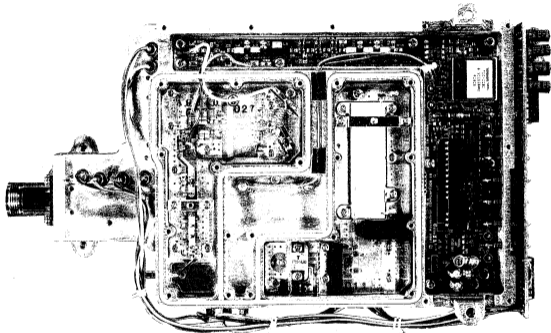

PARTS LOCATION
TG BLOCK 1
WBL-3361TG
BLB-015987
BLD-015988
BTB-015722
BTB-015723

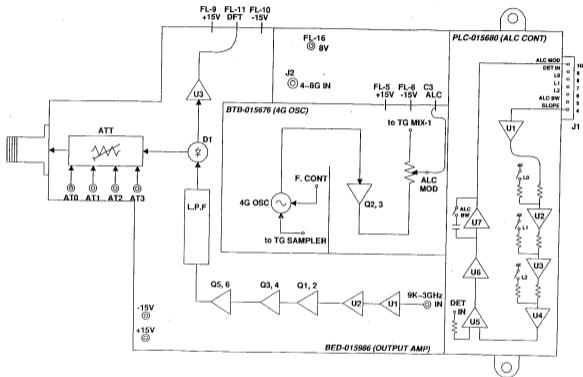

**CIRCUIT LAYOUT
TG BLOCK 2
WBL-3361TG
BED-015986
BLC-015680
BTB-015676**

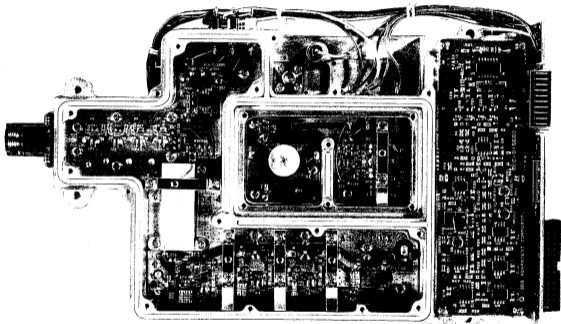

PARTS LOCATION
TG BLOCK 2
WBL-3361TG
BED-015686
BLC-015680
BTB-015676

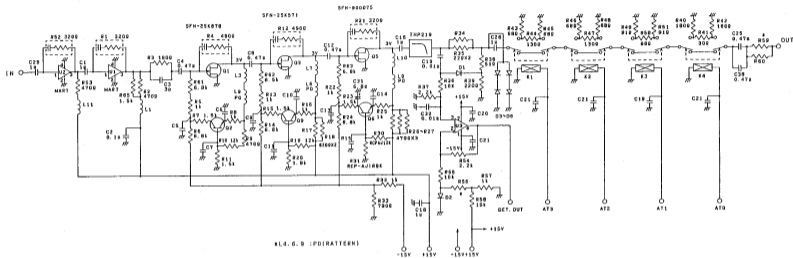

C 8 - 7	CCP-ACR01US0Y
9-11	
13-19	
18-21	
U 1, 2	SIA-MART
U 3	SIA-OPDTP5
U 2, 4, 6	STP-25A1192
D 1	SDS-N04141
U 2	SDS-155242
K 1-4	KRL-000350-2

• R59, R60
ONLY - BED-015986X02

• R56
2001:303
3001:302

R3361 OUTPUT AMP
BED-015986

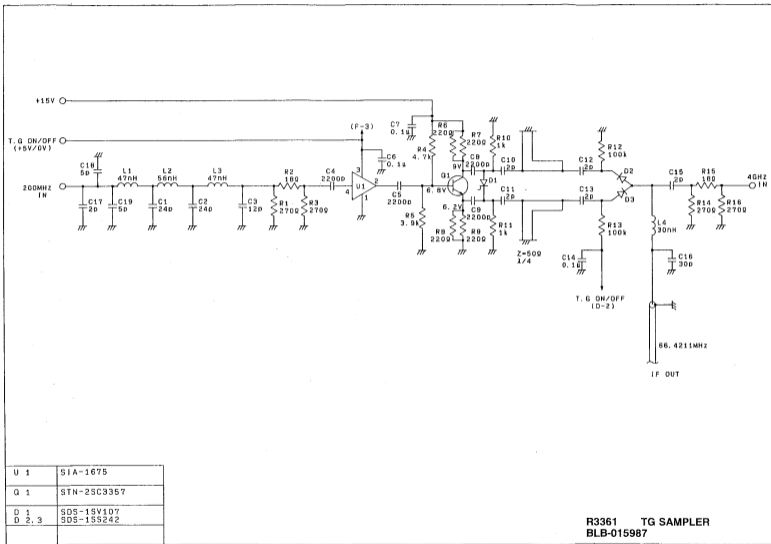

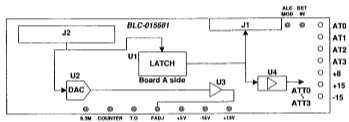

**CIRCUIT LAYOUT
T.G CONT.
BLC-015681**

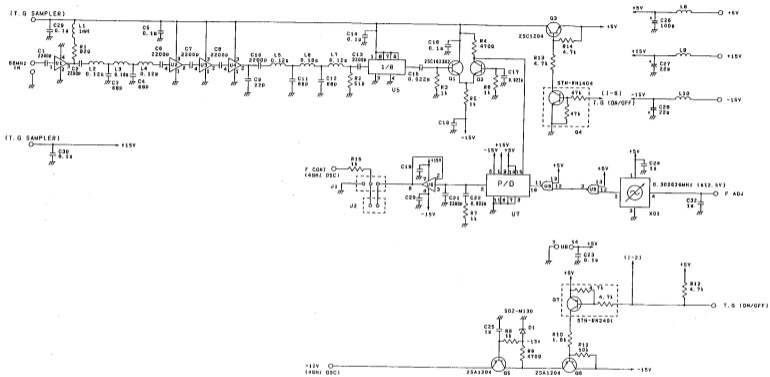

U 1	SIA-MAX6
U 2-4	SIA-1675
U 5	SIC-555
U 6	SIA-DP07P
U 7	SMS-001510
U 8	SIM-74NC00
X01	DXC-001669

R3361 TG PLL
BLD-015988

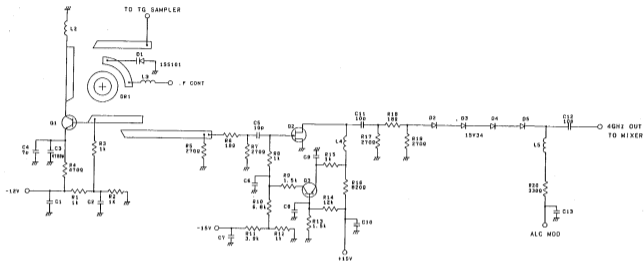

DR1	DXD-001691
C 1, 2, 4, 10, 13	CCP-ACR01U50V
D 1	STN-25C4095
D 2	SN-25C819
D 3	STP-25A11G2
D 1	SDS-15S101
D 2-5	SDS-15V34

R3361 4GHz OSC
BTB-015676

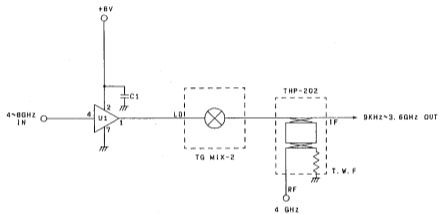

U 1	S1A-59706*14

R3361 TG MIX-1
BTB-015722

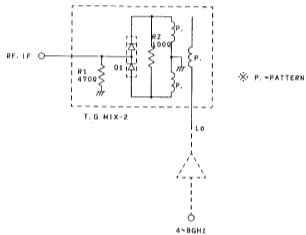

R3361 TG MIX-2
BTB-015723

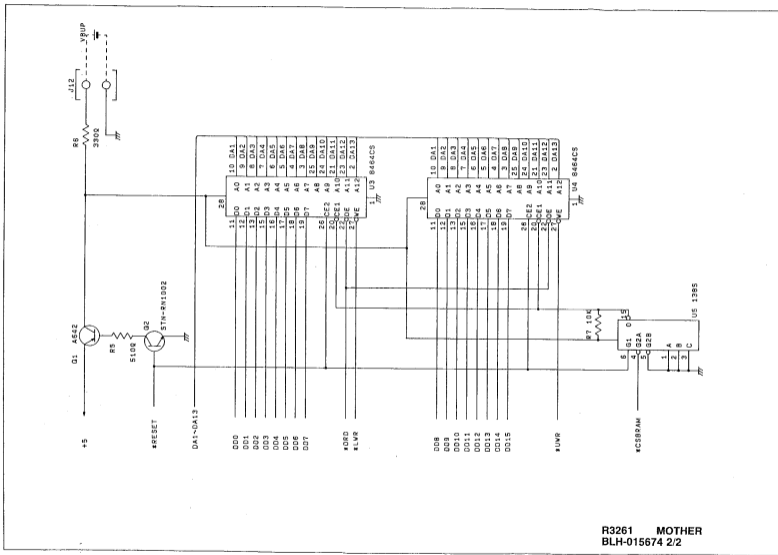

R3261 MOTHER
BLH-015674 2/2



J1: DC9-0R1937 X02

R3261/3361 BATT. HOLDER
BLB-016053

8. REPLACEABLE MECHANICAL PARTS

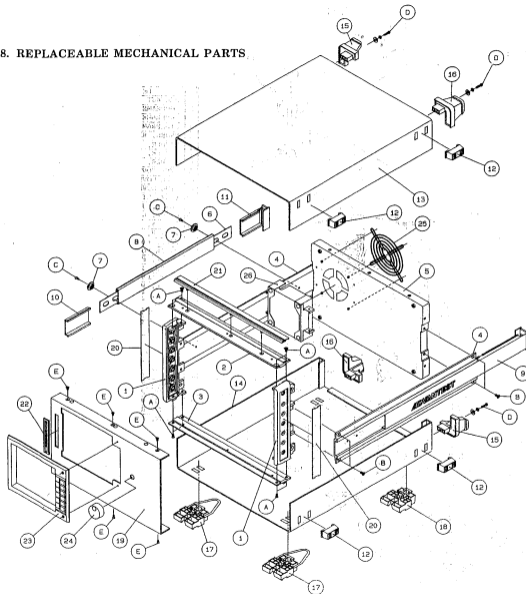

NO.	DESCRIPTION	STOCK NO.	QTY
1	BRACKET	MCT-55603A	2
2	SUBFRAME, UPPER	ME-61712	1
3	SUBFRAME, LOWER	ME-61713	1
4	SIDFRAME	MHT-61471	2
5	PANEL, REAR	MCT-56898A	1
6	HANDLE, INNER	MBE-67474A	1
7	HANDLE, SPACER	MX-32181A	2
8	HANDLE, SLEEVE	MPS-57468A001A	1
9	SIDE COVER, DECORATIVE	MPS-54301A001A	1
10	SIDE COVER, FRONT	MPX-57551A	1
11	SIDE COVER, REAR	MPX-57552A	1
12	FOOT, SIDE	MMX-20403A	4
13	COVER, UPPER	MBX-56917B	1
14	COVER, LOWER	MBX-56918B	1
15	FOOT A, REAR	MMX-54288A	2
16	FOOT B, REAR	MMX-54289A	2
17	STACK FOOT A	HEX-57500A	2
18	STACK FOOT B	HEX-54287A	2
19	PANEL, FRONT	HBS-59698A	1
20	COVER, SIDE BELT	MBX-55737A	2
21	BELT COVER	MPX-59711A	1
22	BRZEL, MEMORY CARD	MMX-61756A	1
23	BRZEL, CRT	MMX-59742A	1
24	KNOB	MMX-54184A	1
25	FINGER GUARD	YEE-900271	1
26	FAN ASSEMBLY	MC4-8110703	1

NO.	DESCRIPTION	SIZE	QTY
A	SCREW, FLAT HEAD	H4XB	8
B	SCREW, FLAT HEAD	H4XB	8
C	SCREW, UNLOOSEN PROCESS	H4XB	2
D	SCREW, ROUND HEAD	M4X30	4
E	SCREW, FLAT HEAD	H4XB	6